

# MATLAB<sup>®</sup>

---

The Language of Technical Computing

Computation

Visualization

Programming



Using MATLAB Graphics  
*Version 6*

## How to Contact The MathWorks:



www.mathworks.com  
comp.soft-sys.matlab

Web  
Newsgroup



support@mathworks.com  
suggest@mathworks.com  
bugs@mathworks.com  
doc@mathworks.com  
service@mathworks.com  
info@mathworks.com

Technical support  
Product enhancement suggestions  
Bug reports  
Documentation error reports  
Order status, license renewals, passcodes  
Sales, pricing, and general information



508-647-7000

Phone



508-647-7001

Fax



The MathWorks, Inc.  
3 Apple Hill Drive  
Natick, MA 01760-2098

Mail

For contact information about worldwide offices, see the MathWorks Web site.

### *Using MATLAB Graphics*

© COPYRIGHT 1984 - 2001 by The MathWorks, Inc.

The software described in this document is furnished under a license agreement. The software may be used or copied only under the terms of the license agreement. No part of this manual may be photocopied or reproduced in any form without prior written consent from The MathWorks, Inc.

**FEDERAL ACQUISITION:** This provision applies to all acquisitions of the Program and Documentation by or for the federal government of the United States. By accepting delivery of the Program, the government hereby agrees that this software qualifies as "commercial" computer software within the meaning of FAR Part 12.212, DFARS Part 227.7202-1, DFARS Part 227.7202-3, DFARS Part 252.227-7013, and DFARS Part 252.227-7014. The terms and conditions of The MathWorks, Inc. Software License Agreement shall pertain to the government's use and disclosure of the Program and Documentation, and shall supersede any conflicting contractual terms or conditions. If this license fails to meet the government's minimum needs or is inconsistent in any respect with federal procurement law, the government agrees to return the Program and Documentation, unused, to MathWorks.

MATLAB, Simulink, Stateflow, Handle Graphics, and Real-Time Workshop are registered trademarks, and Target Language Compiler is a trademark of The MathWorks, Inc.

Other product or brand names are trademarks or registered trademarks of their respective holders.

Printing History:	January 1997	First printing	New for MATLAB 5.1
	January 1998	Second printing	Revised for MATLAB 5.2
	January 1999	Third printing	Revised for MATLAB 5.3 (Release 11)
	September 2000	Fourth printing	Revised for MATLAB 6.0 (Release 12)
	June 2001	Online only	Revised for MATLAB 6.1 (Release 12.1)

## Graphics

### Overview of MATLAB Graphics

1

<b>Introduction</b> .....	<b>1-2</b>
<b>Plotting Your Data</b> .....	<b>1-3</b>
Anatomy of a Plot .....	1-4
<b>Editing a Plot</b> .....	<b>1-5</b>
Interactive Plot Editing .....	1-5
Using Functions to Edit Graphs .....	1-5
<b>Using Plot Editing Mode</b> .....	<b>1-6</b>
Starting Plot Edit Mode .....	1-7
Exiting Plot Edit Mode .....	1-7
Selecting Objects in a Graph .....	1-7
Cutting, Copying, and Pasting Objects .....	1-8
Moving and Resizing Objects .....	1-8
Editing Objects in a Graph .....	1-9
<b>Saving Your Work</b> .....	<b>1-10</b>
Saving a Graph in MAT-File Format .....	1-10
Saving to a Different Format (Exporting Figures) .....	1-11
Printing Figures .....	1-11
Getting Help .....	1-12
<b>Changing Your View of an Axes</b> .....	<b>1-13</b>
Zooming In and Out on an Axes .....	1-13
Rotating 3-D Axes .....	1-14
<b>Using the Property Editor</b> .....	<b>1-15</b>

Starting the Property Editor .....	1-16
Closing the Property Editor .....	1-16
Editing Object Properties .....	1-17
Navigating Among Objects in a Graph .....	1-18
Identifying Objects in a Graph .....	1-20
Applying Your Changes .....	1-21
<b>Using the Data Statistics Tool .....</b>	<b>1-22</b>
Adding Plots of Statistics to a Graph .....	1-22
Saving Statistics to the Workspace .....	1-23

## Basic Plotting

# 2

<b>Basic Plotting Commands .....</b>	<b>2-2</b>
Creating Plots .....	2-2
Specifying Line Style .....	2-4
Specifying the Color and Size of Lines .....	2-6
Adding Plots to an Existing Graph .....	2-7
Plotting Only the Data Points .....	2-8
Plotting Markers and Lines .....	2-9
Line Styles for Black and White Output .....	2-10
Setting Default Line Styles .....	2-11
<b>Line Plots of Matrix Data .....</b>	<b>2-13</b>
<b>Plotting Imaginary and Complex Data .....</b>	<b>2-15</b>
<b>Plotting with Two Y-Axes .....</b>	<b>2-16</b>
Combining Linear and Logarithmic Axes .....	2-16
<b>Setting Axis Parameters .....</b>	<b>2-19</b>
Axis Limits and Ticks .....	2-19
Example – Specifying Ticks and Tick Labels .....	2-22
Setting Aspect Ratio .....	2-24

<b>Figure Windows</b> .....	<b>2-26</b>
Displaying Multiple Plots per Figure .....	<b>2-26</b>
Specifying the Target Axes .....	<b>2-28</b>
Default Color Scheme .....	<b>2-28</b>

## Formatting Graphs

# 3

<b>Overview</b> .....	<b>3-2</b>
<b>Adding a Title to a Graph</b> .....	<b>3-3</b>
Using the Title Option on the Insert Menu .....	<b>3-3</b>
Using the Property Editor to Add a Title .....	<b>3-4</b>
Using the title Function .....	<b>3-5</b>
<b>Adding a Legend to a Graph</b> .....	<b>3-6</b>
Using the Legend Option on the Insert Menu .....	<b>3-7</b>
Using the Legend Function .....	<b>3-7</b>
Positioning a Legend .....	<b>3-8</b>
Editing a Legend .....	<b>3-9</b>
Removing a Legend .....	<b>3-10</b>
<b>Adding Axes Labels to a Graph</b> .....	<b>3-11</b>
Using the Label Options on the Insert Menu .....	<b>3-12</b>
Using the Property Editor to Add Axes labels .....	<b>3-12</b>
Using the Label Commands .....	<b>3-13</b>
<b>Adding Text Annotations to a Graph</b> .....	<b>3-15</b>
Creating Text Annotations in Plot Editing Mode .....	<b>3-16</b>
Creating Text Annotations with the text or gtext Command .	<b>3-16</b>
Example – Aligning Text .....	<b>3-21</b>
Editing Text Annotations .....	<b>3-22</b>
Including Symbols and Greek Letters in Text Strings .....	<b>3-23</b>
Using Variables in Text Strings .....	<b>3-25</b>
Example - Multiline Text .....	<b>3-25</b>
<b>Adding Arrows and Lines to a Graph</b> .....	<b>3-27</b>

Creating Arrows and Lines in Plot Editing Mode .....	3-27
Editing Arrows and Line Annotations .....	3-28
<b>Adding Plots of Basic Statistics to a Graph .....</b>	<b>3-29</b>
Example - Plotting the Mean of a Data Set .....	3-30
Formatting Plots of Data Statistics .....	3-32
Statistics Plotted by the Data Statistics Tool .....	3-32
Viewing Statistics for Multiple Plots .....	3-33
Saving Statistics to the MATLAB Workspace .....	3-34

## Creating Specialized Plots

# 4

<b>Introduction .....</b>	<b>4-2</b>
<b>Bar and Area Graphs .....</b>	<b>4-3</b>
Types of Bar Graphs .....	4-3
Stacked Bar Graphs to Show Contributing Amounts .....	4-6
Specifying X-Axis Data .....	4-8
Overlaying Plots on Bar Graphs .....	4-10
Area Graphs .....	4-12
Comparing Datasets with Area Graphs .....	4-13
<b>Pie Charts .....</b>	<b>4-15</b>
Removing a Piece from a Pie Charts .....	4-17
<b>Histograms .....</b>	<b>4-18</b>
Histograms in Cartesian Coordinate Systems .....	4-18
Histograms in Polar Coordinate Systems .....	4-20
Specifying Number of Bins .....	4-21
<b>Discrete Data Graphs .....</b>	<b>4-23</b>
Two-Dimensional Stem Plots .....	4-23
Combining Stem Plots with Line Plots .....	4-26
Three-Dimensional Stem Plots .....	4-27
Stairstep Plots .....	4-30

<b>Direction and Velocity Vector Graphs</b> .....	<b>4-32</b>
Compass Plots .....	<b>4-32</b>
Feather Plots .....	<b>4-33</b>
Two-Dimensional Quiver Plots .....	<b>4-35</b>
Three-Dimensional Quiver Plots .....	<b>4-36</b>
<b>Contour Plots</b> .....	<b>4-38</b>
Creating Simple Contour Plots .....	<b>4-38</b>
Labeling Contours .....	<b>4-40</b>
Filled Contours .....	<b>4-41</b>
Drawing a Single Contour Line at a Desired Level .....	<b>4-42</b>
The Contouring Algorithm .....	<b>4-43</b>
Changing the Offset of a Contour .....	<b>4-44</b>
Displaying Contours in Polar Coordinates .....	<b>4-45</b>
<b>Interactive Plotting</b> .....	<b>4-49</b>
<b>Animation</b> .....	<b>4-51</b>
Movies .....	<b>4-51</b>
Example – Visualizing an FFT as a Movie .....	<b>4-52</b>
Erase Modes .....	<b>4-53</b>

## Displaying Bit-Mapped Images

# 5

<b>Overview</b> .....	<b>5-2</b>
<b>Images in MATLAB</b> .....	<b>5-4</b>
Data Types .....	<b>5-4</b>
<b>Image Types</b> .....	<b>5-6</b>
Indexed Images .....	<b>5-6</b>
Intensity Images .....	<b>5-7</b>
RGB (Truecolor) Images .....	<b>5-9</b>
<b>Working with 8-Bit and 16-Bit Images</b> .....	<b>5-11</b>
8-Bit and 16-Bit Indexed Images .....	<b>5-11</b>

8-Bit and 16-Bit Intensity Images .....	5-12
8-Bit and 16-Bit RGB Images .....	5-12
Mathematical Operations Support for uint8 and uint16 .....	5-13
Other 8-Bit and 16-Bit Array Support .....	5-13
Summary of Image Types and Numeric Classes .....	5-14
<b>Reading, Writing, and Querying Graphics Image Files ...</b>	<b>5-15</b>
Reading a Graphics Image .....	5-15
Writing a Graphics Image .....	5-16
Obtaining Information About Graphics Files .....	5-16
<b>Displaying Graphics Images .....</b>	<b>5-18</b>
Summary of Image Types and Display Methods .....	5-19
Controlling Aspect Ratio and Display Size .....	5-19
<b>The Image Object and Its Properties .....</b>	<b>5-23</b>
CData .....	5-23
CDataMapping .....	5-23
XData and YData .....	5-24
EraseMode .....	5-26
<b>Printing Images .....</b>	<b>5-28</b>
<b>Converting the Data or Graphic Type of Images .....</b>	<b>5-29</b>

## Basic Printing and Exporting

# 6

<b>Quick Start .....</b>	<b>6-3</b>
List of Examples .....	6-3
Dialog Box Overview .....	6-3
Printing to a Printer Using the Defaults .....	6-4
Printing to a Printer at Screen Size .....	6-6
Printing to a Printer, Locking the Ticks and Limits of the Axes	6-7
Printing to a Printer, Setting the Paper Size .....	6-8
Printing to a Printer, Setting the Size of and	
Centering a Figure .....	6-9



Printing to a Nondefault Printer . . . . .	6-11
Printing to a Printer Using GhostScript . . . . .	6-13
Printing a Figure to a File . . . . .	6-14
Appending a Figure to a PostScript File . . . . .	6-16
Exporting a Figure to a File in a Specific Graphics Format . . . . .	6-16
Exporting a Figure in EPS Format with a TIFF Preview . . . . .	6-18
Exporting a Figure to the Clipboard . . . . .	6-18
<b>Overview of Printing and Exporting . . . . .</b>	<b>6-22</b>
What Is Printed or Exported . . . . .	6-22
Which Figure Is Printed . . . . .	6-22
How to Print or Export . . . . .	6-23
Default Settings and How to Change Them . . . . .	6-23
<b>Printing a Figure to a Printer or a File . . . . .</b>	<b>6-26</b>
Using Print Dialog Boxes . . . . .	6-26
From the Command Line . . . . .	6-27
Changing the Figure's Settings . . . . .	6-30
Printing the Figure . . . . .	6-41
<b>Exporting a Figure in Graphics Format . . . . .</b>	<b>6-47</b>
Exporting to a File . . . . .	6-48
Exporting to the Clipboard . . . . .	6-50
<b>Troubleshooting . . . . .</b>	<b>6-55</b>
Printing Problems . . . . .	6-56
Exporting Problems . . . . .	6-59
General Problems . . . . .	6-63

## Handle Graphics Objects

# 7

<b>Overview . . . . .</b>	<b>7-2</b>
<b>Graphics Object Hierarchy . . . . .</b>	<b>7-3</b>
<b>Types of Graphics Objects . . . . .</b>	<b>7-4</b>

Handle Graphics Objects .....	7-5
<b>Object Properties .....</b>	<b>7-9</b>
Changing Values .....	7-9
Default Values .....	7-9
Properties Common to All Objects .....	7-10
<b>Graphics Object Creation Functions .....</b>	<b>7-12</b>
Example – Creating Graphics Objects .....	7-13
Parenting .....	7-15
High-Level Versus Low-Level .....	7-15
Simplified Calling Syntax .....	7-16
<b>Setting and Querying Property Values .....</b>	<b>7-18</b>
Setting Property Values .....	7-18
Querying Property Values .....	7-20
Factory-Defined Property Values .....	7-22
<b>Setting Default Property Values .....</b>	<b>7-23</b>
How MATLAB Searches for Default Values .....	7-23
Defining Default Values .....	7-25
Examples – Setting Default LineStyles .....	7-26
<b>Accessing Object Handles .....</b>	<b>7-30</b>
The Current Figure, Axes, and Object .....	7-30
Searching for Objects by Property Values — findobj .....	7-32
Copying Objects .....	7-33
Deleting Objects .....	7-35
<b>Controlling Graphics Output .....</b>	<b>7-37</b>
Specifying the Target for Graphics Output .....	7-37
Preparing Figures and Axes for Graphics .....	7-37
Targeting Graphics Output with newplot .....	7-39
Example – Using newplot .....	7-40
Testing for Hold State .....	7-42
Protecting Figures and Axes .....	7-43
The Close Request Function .....	7-45
Handle Validity Versus Handle Visibility .....	7-46

<b>Saving Handles in M-Files</b> .....	<b>7-48</b>
<b>Properties Changed by Built-In Functions</b> .....	<b>7-49</b>

## Axes Properties

# 8

<b>Axes Topics</b> .....	<b>8-2</b>
<b>Labeling and Appearance Properties</b> .....	<b>8-3</b>
Creating Axes with Specific Characteristics .....	<b>8-3</b>
<b>Positioning Axes</b> .....	<b>8-5</b>
The Position Vector .....	<b>8-5</b>
Units .....	<b>8-6</b>
<b>Multiple Axes per Figure</b> .....	<b>8-7</b>
Placing Text Outside the Axes .....	<b>8-7</b>
Multiple Axes for Different Scaling .....	<b>8-8</b>
<b>Individual Axis Control</b> .....	<b>8-10</b>
Setting Axis Limits .....	<b>8-11</b>
Setting Tick Mark Locations .....	<b>8-12</b>
Changing Axis Direction .....	<b>8-13</b>
<b>Using Multiple X and Y Axes</b> .....	<b>8-16</b>
Example – Double Axis Graphs .....	<b>8-16</b>
<b>Automatic-Mode Properties</b> .....	<b>8-19</b>
<b>Colors Controlled by Axes</b> .....	<b>8-22</b>
Specifying Axes Colors .....	<b>8-22</b>
Axes Color Limits – The CLim Property .....	<b>8-25</b>
Example – Simulating Multiple Colormaps in a Figure .....	<b>8-25</b>
Calculating Color Limits .....	<b>8-26</b>
Defining the Color of Lines for Plotting .....	<b>8-29</b>
Line Styles Used for Plotting – LineStyleOrder .....	<b>8-31</b>

<b>Figure Topics</b> .....	<b>9-2</b>
<b>Positioning Figures</b> .....	<b>9-3</b>
The Position Vector .....	<b>9-3</b>
Example – Specifying Figure Position .....	<b>9-5</b>
<b>Controlling How MATLAB Uses Color</b> .....	<b>9-7</b>
Indexed Color Displays .....	<b>9-7</b>
Colormap Colors and Fixed Colors .....	<b>9-8</b>
Using a Large Number of Colors .....	<b>9-9</b>
Nonactive Figures and Shared Colors .....	<b>9-11</b>
Dithering Truecolor on Indexed Color Systems .....	<b>9-12</b>
<b>Selecting Drawing Methods</b> .....	<b>9-15</b>
Backing Store .....	<b>9-15</b>
Double Buffering .....	<b>9-15</b>
Selecting a Renderer .....	<b>9-16</b>
<b>Specifying the Figure Pointer</b> .....	<b>9-18</b>
Defining Custom Pointers .....	<b>9-19</b>
<b>Interactive Graphics</b> .....	<b>9-23</b>

## **3-D Visualization**

<b>Topics in 3-D Graphing</b> .....	<b>10-2</b>
<b>A Typical 3-D Graph</b> .....	<b>10-3</b>

<b>Line Plots of 3-D Data</b> .....	<b>10-4</b>
<b>Representing a Matrix As a Surface</b> .....	<b>10-6</b>
Mesh and Surface Plots .....	<b>10-6</b>
Visualizing Functions of Two Variables .....	<b>10-7</b>
Surface Plots of Nonuniformly Sampled Data .....	<b>10-9</b>
Parametric Surfaces .....	<b>10-11</b>
Hidden Line Removal .....	<b>10-13</b>
<b>Coloring Mesh and Surface Plots</b> .....	<b>10-14</b>
Colormaps .....	<b>10-14</b>
Indexed Colors – Direct and Scaled Colormapping .....	<b>10-17</b>
Example – Mapping Surface Curvature to Color .....	<b>10-18</b>
Altering Colormaps .....	<b>10-20</b>
<b>Truecolor</b> .....	<b>10-22</b>
<b>Texture Mapping</b> .....	<b>10-25</b>

## Defining the View

# 11

<b>View Definition Topics</b> .....	<b>11-2</b>
<b>Setting the Viewpoint</b> .....	<b>11-4</b>
Specifying Azimuth and Elevation .....	<b>11-4</b>
<b>Defining Scenes with Camera Graphics</b> .....	<b>11-8</b>
<b>View Control with the Camera Toolbar</b> .....	<b>11-9</b>
Camera Toolbar .....	<b>11-9</b>
Camera Motion Controls .....	<b>11-12</b>
Orbit Camera .....	<b>11-12</b>
Orbit Scene Light .....	<b>11-13</b>
Pan/Tilt Camera .....	<b>11-14</b>
Move Camera Horizontally/Vertically .....	<b>11-15</b>
Move Camera Forward and Backwards .....	<b>11-16</b>

Zoom Camera .....	11-17
Camera Roll .....	11-18
Walk Camera .....	11-19
<b>Camera Graphics Functions .....</b>	<b>11-21</b>
<b>Dollying the Camera .....</b>	<b>11-22</b>
<b>Moving the Camera Through a Scene .....</b>	<b>11-24</b>
Summary of Techniques .....	11-24
Graphing the Volume Data .....	11-24
Setting Up the View .....	11-25
Specifying the Light Source .....	11-25
Selecting a Renderer .....	11-26
Defining the Camera Path as a Stream Line .....	11-26
Implementing the Fly-Through .....	11-26
<b>Low-Level Camera Properties .....</b>	<b>11-30</b>
Default Viewpoint Selection .....	11-31
Moving In and Out on the Scene .....	11-31
Making the Scene Larger or Smaller .....	11-33
Revolving Around the Scene .....	11-33
Rotation Without Resizing of Graphics Objects .....	11-33
Rotation About the Viewing Axis .....	11-34
<b>View Projection Types .....</b>	<b>11-36</b>
Projection Types and Camera Location .....	11-37
<b>Understanding Axes Aspect Ratio .....</b>	<b>11-41</b>
Stretch-to-Fill .....	11-41
Specifying Axis Scaling .....	11-41
Specifying Aspect Ratio .....	11-42
Example – axis Command Options .....	11-43
Additional Commands for Setting Aspect Ratio .....	11-45
<b>Axes Aspect Ratio Properties .....</b>	<b>11-46</b>
Default Aspect Ratio Selection .....	11-47
Overriding Stretch-to-Fill .....	11-49

Effects of Setting Aspect Ratio Properties .....	11-50
Example – Displaying Real Objects .....	11-54

## Lighting as a Visualization Tool

# 12

<b>Lighting</b> .....	12-2
Lighting Examples .....	12-2
<b>Lighting Commands</b> .....	12-3
<b>Light Objects</b> .....	12-4
<b>Adding Lights to a Scene</b> .....	12-5
<b>Properties That Affect Lighting</b> .....	12-8
<b>Selecting a Lighting Method</b> .....	12-10
Face and Edge Lighting Methods .....	12-10
<b>Reflectance Characteristics of Graphics Objects</b> .....	12-12
Specular and Diffuse Reflection .....	12-12
Ambient Light .....	12-13
Specular Exponent .....	12-14
Specular Color Reflectance .....	12-15
Back Face Lighting .....	12-15
Positioning Lights in Data Space .....	12-18

## Transparency

# 13

<b>Transparency Topics</b> .....	13-2
<b>Making Objects Transparent</b> .....	13-3

Specifying Transparency .....	13-4
<b>Specifying a Single Transparency Value .....</b>	<b>13-6</b>
Example – Transparent Isosurface .....	13-6
<b>Mapping Data to Transparency .....</b>	<b>13-8</b>
Size of the Alpha Data Array .....	13-9
Mapping Alpha Data to the Alphamap .....	13-9
Example: Mapping Data to Color or Transparency .....	13-9
<b>Selecting an Alphamap .....</b>	<b>13-11</b>
Example: Modifying the Alphamap .....	13-13

## Creating 3-D Models with Patches

# 14

<b>Introduction to Patch Objects .....</b>	<b>14-2</b>
Defining Patches .....	14-2
Behavior of the patch Function .....	14-2
Creating a Single Polygon .....	14-4
<b>Multi-Faceted Patches .....</b>	<b>14-6</b>
Example – Defining a Cube .....	14-6
<b>Specifying Patch Coloring .....</b>	<b>14-11</b>
<b>Face and Edge Coloring .....</b>	<b>14-13</b>
Example – Specifying Flat Edge and Face Coloring .....	14-13
Coloring Edges with Shared Vertices .....	14-14
<b>How MATLAB Interprets Patch Color Data .....</b>	<b>14-16</b>
Indexed Color Data .....	14-16
Truecolor Patches .....	14-19
Interpolating in Indexed Color Versus Truecolor .....	14-19



<b>Volume Visualization Topics</b> .....	<b>15-2</b>
<b>Overview of Volume Visualization</b> .....	<b>15-3</b>
Examples of Volume Data .....	<b>15-3</b>
Selecting Visualization Techniques .....	<b>15-3</b>
Steps to Create a Volume Visualization .....	<b>15-4</b>
<b>Volume Visualization Functions</b> .....	<b>15-5</b>
<b>Visualizing Scalar Volume Data</b> .....	<b>15-7</b>
Techniques for Visualizing Scalar Data .....	<b>15-7</b>
<b>Visualizing MRI Data</b> .....	<b>15-8</b>
<b>Exploring Volumes with Slice Planes</b> .....	<b>15-14</b>
Example – Slicing Fluid Flow Data .....	<b>15-14</b>
Modifying the Color Mapping .....	<b>15-17</b>
<b>Connecting Equal Values with Isosurfaces</b> .....	<b>15-19</b>
Example – Isosurfaces in Fluid Flow Data .....	<b>15-19</b>
<b>Isocaps Add Context to Visualizations</b> .....	<b>15-21</b>
Defining Isocaps .....	<b>15-22</b>
Example – Adding Isocaps to an Isosurface .....	<b>15-23</b>
<b>Visualizing Vector Volume Data</b> .....	<b>15-25</b>
Using Scalar Techniques with Vector Data .....	<b>15-25</b>
Specifying Starting Points for Stream Plots .....	<b>15-26</b>
Accessing Subregions of Volume Data .....	<b>15-28</b>
<b>Stream Line Plots of Vector Data</b> .....	<b>15-30</b>
<b>Displaying Curl with Stream Ribbons</b> .....	<b>15-32</b>
<b>Displaying Divergence with Stream Tubes</b> .....	<b>15-34</b>

<b>Creating Stream Particle Animations</b> .....	<b>15-37</b>
<b>Vector Field Displayed with Cone Plots</b> .....	<b>15-40</b>

---

# Graphics

---

MATLAB<sup>®</sup> provides many graphics functions that allow you to create 2-D plots of your data. This collection includes the following topics.

- Overview of MATLAB Graphics – plot editing mode and the Property Editor.
- Basic Plotting – plotting vector and matrix data in 2-D representations.
- Formatting Graphs – describes how to customize the format of a plot to help explain your data. This section includes information about adding labels, titles, and annotations to a plot.
- Creating Specialized Plots – describes how to create bar graphs, histograms, and contour plots.
- Basic Printing and Exporting – describes frequently used ways to print or export a MATLAB figure, and explains the basic printing and exporting interfaces.
- Handle Graphics<sup>®</sup> Objects – introduces MATLAB's graphics objects and properties.
- Figure Properties – discusses the features that are implemented with figure properties.
- Axes Properties – discusses the features that are implemented with axes properties.

## Related Information

These other collections provide additional information about plotting.

- 3-D Visualization describes how to use views and lighting to achieve more complex graphic effects than can be achieved using the basic plotting functions.
- Creating GUIs describes how to include menus, push buttons, text boxes, and other user interface objects in MATLAB applications.

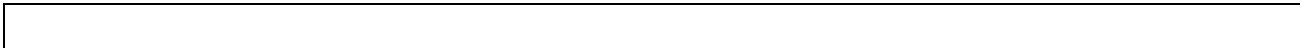

# Overview of MATLAB Graphics

---

<b>Introduction</b> . . . . .	1-2
<b>Plotting Your Data</b> . . . . .	1-3
<b>Editing a Plot</b> . . . . .	1-5
<b>Using Plot Editing Mode</b> . . . . .	1-6
<b>Saving Your Work</b> . . . . .	1-10
<b>Changing Your View of an Axes</b> . . . . .	1-13
<b>Using the Property Editor</b> . . . . .	1-15
<b>Using the Data Statistics Tool</b> . . . . .	1-22

## Introduction

MATLAB includes extensive plotting capabilities. This section provides an overview of these capabilities, including:

- “Plotting Your Data” on page 1-3
- “Editing a Plot” on page 1-5
- “Saving Your Work” on page 1-10
- “Changing Your View of an Axes” on page 1-13
- “Using the Property Editor” on page 1-15
- “Using the Data Statistics Tool” on page 1-22

## Plotting Your Data

The process of constructing a basic graph to meet your presentation graphics requirements is outlined in the following table. The table shows seven typical steps and some example code for each.

If you are performing analysis only, you may want to view various graphs just to explore your data. In this case, steps 1 and 3 may be all you need. If you are creating presentation graphics, you may want to fine-tune your graph by positioning it on the page, setting line styles and colors, adding annotations, and making other such improvements.

Step	Typical Code
1 Prepare your data	<pre>x = 0:0.2:12; y1 = bessell(1,x); y2 = bessell(2,x); y3 = bessell(3,x);</pre>
2 Select a window and position a plot region within the window	<pre>figure(1) subplot(2,2,1)</pre>
3 Call elementary plotting function	<pre>h = plot(x,y1,x,y2,x,y3);</pre>
4 Select line and marker characteristics	<pre>set(h,'LineWidth',2,{'LineStyle'},{'--';':';'-.'}) set(h,{'Color'},{'r';'g';'b'})</pre>
5 Set axis limits, tick marks, and grid lines	<pre>axis([0 12 -0.5 1]) grid on</pre>
6 Annotate the graph with axis labels, legend, and text	<pre>xlabel('Time') ylabel('Amplitude') legend(h,'First','Second','Third') title('Bessel Functions') [y,ix] = min(y1); text(x(ix),y,'First Min \rightarrow',...       'HorizontalAlignment','right')</pre>
7 Export graph	<pre>print -depsc -tiff -r200 myplot</pre>

## Anatomy of a Plot

MATLAB plotting functions direct their output to a window that is separate from the command window. In MATLAB this window is referred to as a *figure*. For example, the following illustrates the plot of the Bessel functions, described in “Plotting Your Data” on page 1-3, highlighting the basic components of the graph.

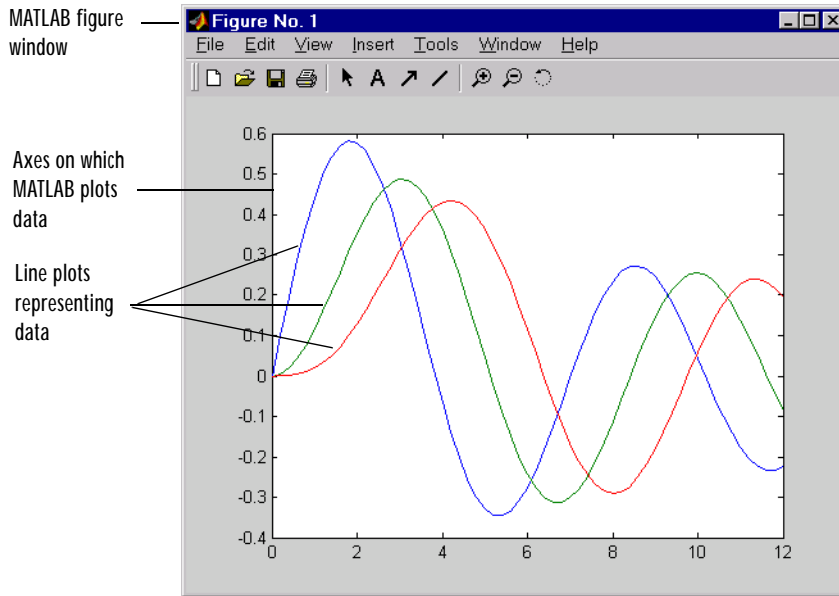

By default, MATLAB uses line style and color to distinguish the data sets plotted in the graph. However, you can change the appearance of these graphic components or add annotations to the graph to help explain your data for presentation graphics. For information, see “Editing a Plot” on page 1-5.



## Editing a Plot

MATLAB formats a graph to provide readability, setting the scale of axes, including tick marks on the axes, and using color and line style to distinguish the plots in the graph. However, if you are creating presentation graphics, you may want to change this default formatting or add descriptive labels, titles, legends and other annotations to help explain your data.

MATLAB supports two ways to edit the plots you create.

- Using the mouse to select and edit objects interactively
- Using MATLAB functions at the command-line or in an M-file

### Interactive Plot Editing

If you enable plot editing mode in the MATLAB figure window, you can perform point-and-click editing of your graph. In this mode, you can change the format of objects in your graph by double-clicking on the object and changing the values of its properties. In plot editing mode, you access the properties through the graphical user interface, called the Property Editor.

For more information about interactive editing, see “Using Plot Editing Mode” on page 1-6. For information about editing object properties in plot editing mode, see “Using the Property Editor” on page 1-15.

### Using Functions to Edit Graphs

If you prefer to work from the MATLAB command line or if you are creating an M-file, you can use MATLAB commands to edit the graphs you create. Taking advantage of MATLAB’s Handle Graphics system, you can use the `set` and `get` commands to change the properties of the objects in a graph.

---

**Note** Plot editing mode provides an alternative way to access the properties of MATLAB graphic objects. However, you can only access a subset of object properties through this mechanism. You may need to use a combination of interactive editing and command line editing to achieve the effect you desire.

---

## Using Plot Editing Mode

To start plot edit mode, click this button.

Use the **Edit**, **Insert**, and **Tools** menus to add objects or edit existing objects in a graph.

Double-click on an object to select it.

Position labels, legends, and other objects by clicking and dragging.

Access object-specific plot edit functions through context-sensitive pop-up menus.

Use these toolbar buttons to add text, arrows, and lines.

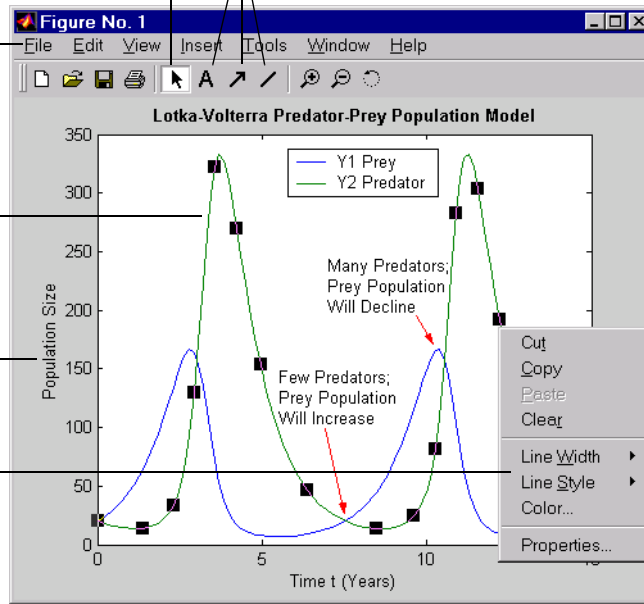

The MATLAB figure window supports a point-and-click style editing mode that you can use to customize the appearance of your graph. This section describes how to start plot edit mode and perform basic editing tasks, including:

- “Selecting Objects in a Graph” on page 1-7
- “Cutting, Copying, and Pasting Objects” on page 1-8
- “Moving and Resizing Objects” on page 1-8
- “Editing Objects in a Graph” on page 1-9
- “Saving Your Work” on page 1-10
- “Changing Your View of an Axes” on page 1-13

## Starting Plot Edit Mode

Before you can select objects in a figure by clicking on them, you must activate plot editing mode. There are several ways to activate plot edit mode:

- Choose the **Edit Plot** option on the figure window **Tools** menu.
- Click on the selection button in the figure window toolbar.

Click this button to start plot edit mode.



- Choose an option from the **Edit** or **Insert** menu. For example, if you choose the **Axes Properties** option on the **Edit** menu, MATLAB activates plot edit mode and the axes appear selected.
- Run the `plottedit` command in the MATLAB command window.

When a figure window is in plot edit mode, the **Edit Plot** option on the **Tools** menu is checked and the selection button in the toolbar is highlighted.

## Exiting Plot Edit Mode

To exit plot edit mode, click the selection button or click the **Edit Plot** option on the **Tools** menu. When plot edit mode is turned off, the selection button is no longer highlighted.

## Selecting Objects in a Graph

To select an object in a graph:

- 1 Start plot edit mode.
- 2 Move the cursor over the object and click on it.

Selection handles appear on the selected object.

## Selecting Multiple Objects

To select multiple objects at the same time:

- 1 Start plot edit mode.

- 2 Move the cursor over an object and shift-click to select it. Repeat for each object you want to select.

You can perform actions on all of the selected objects. For example, to remove a text annotation and an arrow annotation from a graph, select the objects and then select **Cut** from the **Edit** menu.

## Deselecting Objects

To deselect an object, move the cursor off the object onto the figure window background and click the left mouse button. You can also shift-click on a selected object to deselect it.

## Cutting, Copying, and Pasting Objects

To cut an object from a graph, or copy and paste an object in a graph, perform these steps.

- 1 Start plot edit mode.
- 2 Select the object.
- 3 Select the **Cut**, **Copy**, or **Paste** option from the **Edit** menu or use standard shortcut keys for your platform.

Alternatively, with plot edit mode enabled, you can right-click on an object and then select an editing command from the context menu associated with the object.

---

**Note** If you cut an axes label or title and then paste it back into a figure, the label or title is no longer anchored to the axis. If you move the axes, the label or title will not move with the axes.

---

## Moving and Resizing Objects

To move or resize an object in a graph, perform these steps.

- 1 Start plot edit mode.

- 2 For axes objects only: unlock the axes by right-clicking on it and choosing **Unlock Axes Position** from the context menu.
- 3 Select the object. Selection handles appear on the object.

To move the object, drag it to the new location.

To resize the object, drag a selection handle.

---

**Note** You can move, but cannot resize text objects.

---

## Editing Objects in a Graph

In MATLAB, every object in a graph supports a set of properties that control the graph's appearance and behavior. For example, line objects support properties that control thickness, color, and line style.

In plot edit mode, MATLAB provides a graphical user interface to object properties called the Property Editor. The Property Editor is a dialog box that supports a specific set of tabbed panels for each object you can select. For more information, see “Using the Property Editor” on page 1-15.

## Saving Your Work

After editing a graph, you can:

- Save your work in a format that can be opened during another MATLAB session.
- Save your work in a format that can be used by other applications.

### Saving a Graph in MAT-File Format

MATLAB supports a binary format in which you can save figures so that they can be opened in subsequent MATLAB sessions. MATLAB assigns these files the `.fig` file name extension.

To save a graph in a figure file:

- 1 Select **Save** from the figure window **File** menu or click the **Save** button on the toolbar. If this is the first time you are saving the file, the **Save As** dialog box appears.
- 2 Make sure that the **Save as type** is **Fig-file**.
- 3 Specify the name you want assigned to the figure file.
- 4 Click **OK**.

The graph is saved as a figure file (`.fig`), which is a binary file format used to store figures.

You can also use the `saveas` command.

If you want to save the figure in a format that can be used by another application, see “Saving to a Different Format (Exporting Figures)” on page 1-11.

### Opening a Figure File

To open a figure file, perform these steps.

- 1 Select **Open** from the **File** menu or click the **Open** button on the toolbar.

- 2 Select the figure file you want to open and click **OK**.

The figure file appears in a new figure window.

You can also use the open command.

## Saving to a Different Format (Exporting Figures)

To save a figure in a format that can be used by another application, such as the standard graphics file formats TIFF or EPS, perform these steps:

- 1 Select **Export** from the figure window **File** menu. The **Export** dialog box appears.
- 2 Select the format from the list of formats in the **Save as type:** menu. This selects the standard filename extension given to files of that type.
- 3 Enter the name you want to give the file.
- 4 Click **Save**.

## Copying a Figure to the Clipboard

On Windows systems, you can also copy a figure to the clipboard and then paste it into another application:

- 1 Select **Copy Options** from the Figure window **Edit** menu. The **Copying Options** page of the **Preferences** dialog box appears.
- 2 Complete the fields on the **Copying Options** page and click **OK**.
- 3 Select **Copy Figure** from the **Edit** menu.

The figure is copied to the Windows clipboard. You can then paste the figure from the Windows clipboard into a file in another application.

## Printing Figures

Before printing a figure:

- 1 Select **Page Setup** from the figure window **File** menu to set printing options.

The **Page Setup** dialog box opens.

- 2 Make changes in the dialog box. If you want the printed output to exactly match the annotated plot you see on the screen:
  - a On the **Axes and Figure** tab, click **Keep screen limits and ticks**.
  - b On the **Size and Position** tab, click **Use screen size, centered on page**.

For more information about other options for page setup, click the **Help** button in the dialog box.

To print a figure, select **Print** from the figure window **File** menu and complete the **Print** dialog box that appears.

You can also use the `print` command.

## Getting Help

To access help for the plot editing mode, select **Plot Editing** from the figure window **Help** menu. You can also access help at the command line by typing `help plottedit` or `doc plottedit`. For information about other graphics features, select **Graphics** from the figure window **Help** menu.



## Changing Your View of an Axes

MATLAB lets you change your view of axes by either zooming in for a closer look at a portion of an axes or, for 3-D axes, rotating the axes.

- “Zooming In and Out on an Axes” on page 1-13
- “Rotating 3-D Axes” on page 1-14

The zoom and rotate 3-D options provides basic view changing capabilities. For more advanced viewing, select the Camera option from the Tools menu. See for more information.

---

**Note** Activating any of the zoom, rotate, or camera functions automatically turns off plot editing mode.

---

### Zooming In and Out on an Axes

The zoom in function lets you get a closer view of a portion of an axes. The zoom out function lets you view a larger portion of an axes.

To zoom in on a portion of axes:

- 1 Activate the zoom function by choosing the **Zoom In** option on the **Tools** menu or by clicking the Zoom In button in the toolbar.

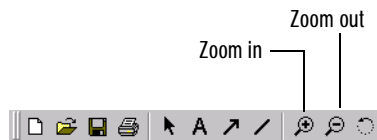

- 2 Click on the area of the axes where you want to zoom in, or drag the cursor to draw a box around the area where you want to zoom in.

MATLAB redraws the axes, zooming in on the area you specified. To further magnify the area, click repeatedly in the axes or draw additional boxes in the axes. To end zoom in mode, click the Zoom In button.

---

**Note** Properties of the axes, such as the tick marks, automatically adjust to the new magnification or orientation. Annotations do not.

---

To zoom out from an axes, click the Zoom Out button on the toolbar and then click on an area of the axes where you want to zoom out. To end zoom out mode, click the Zoom Out button.

The zoom buttons use the `camzoom` command.

## Rotating 3-D Axes

To rotate a 3-D axes:

- 1 Activate the rotate 3-D function by choosing the **Rotate 3-D** option on the **Tools** menu or by clicking the Rotate 3-D button in the toolbar.



---

**Note** Activating the rotate 3-D function automatically turns off plot editing mode.

---

- 2 Click on the axes and an outline of the figure appears in the axes to help you visualize the rotation. Drag the cursor in the direction you want to rotate. When you release the mouse button, MATLAB redraws the axes in the new orientation.
- 3 Click the rotate button again to end rotate 3-D mode.

The Rotate 3-D button uses the `rotate3d` command.

## Using the Property Editor

The Property Editor provides access to many properties of objects in a graph, including figures, axes, lines, lights, patches, images, surfaces, rectangles, text, and the root object.

Use these buttons to move back and forth among the graphics objects you have edited.

Use the navigation bar to select the object you want to edit.

Click on a tab to view a group of properties.

Click here to view a list of values for this field.

Check this box to see the effect of your changes as you make them.

Click OK to apply your changes and dismiss the Property Editor.

Click Cancel to dismiss the Property Editor without applying your changes.

Click Apply to apply your changes without dismissing the Property Editor.

Click Help to get information about particular properties.

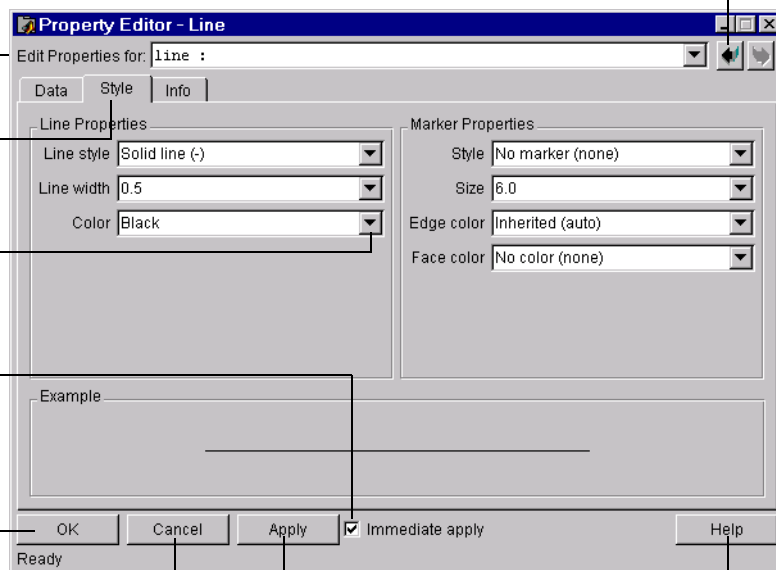

This section describes:

- Starting the Property Editor
- “Editing Object Properties” on page 1-17
- “Navigating Among Objects in a Graph” on page 1-18
- “Applying Your Changes” on page 1-21

## Starting the Property Editor

There are several ways to start the Property Editor.

If plot editing mode is enabled, you can:

- Double-click on an object in the graph.
- 

**Note** Double-clicking on a text object does not start the Property Editor. It opens a edit box around the text. To modify the properties of a text object, use one of the other mechanisms.

---

- Right-click on an object, view the context menu, and select the **Properties** option. The context menus associated with objects also provide direct access to certain commonly used properties.
- Select **Figure Properties**, **Axes Properties**, or **Current Object Properties** from the figure window **Edit** menu. These options automatically enable plot editing mode, if it is not already enabled.

You can also start the Property Editor from the command line using the `propedit` function.

---

**Note** Once you start the Property Editor, keep it open throughout an editing session. If you click on another object in the graph, the Property Editor displays the set of panels associated with that object type. You can also use the navigation bar in the Property Editor to select other objects to edit in the graph.

---

## Closing the Property Editor

Once activated, the Property Editor remains on your screen until you explicitly dismiss it by clicking either the **Cancel** button or the **OK** button. The **Cancel** button dismisses the Property Editor without applying any changes that may have been made to property values that haven't been applied. The **OK** button dismisses the Property Editor dialog box and applies any changes that have been made to property values.

## Editing Object Properties

To edit the properties of an object:

- 1 Start plot editing mode.
- 2 Start the Property Editor by double-clicking on the object in the graph or using one of the other mechanisms.

The Property Editor displays the set of panels associated with the object you have selected.

- 3 Click on the tab of the panel that contains the property you want to modify.
- 4 Change the value of the property. For some properties, you must select a value from a menu of values. For other fields, you can either select a value or type a value directly into the field.

---

**Note** If you place the cursor over a field, a data tip appears that displays the name of the property being edited and its current value.

---

- 5 Click the **Apply** button.

For example, if you double-click on a line object in a graph, the Property Editor displays the set of tabbed panels specific to line objects: **Data**, **Style**, and **Info**. To change the style of a line from solid to dashed, click on the Style tab to view

the style panel and click on the **Line style** menu. Select **Dashed line** from the list of styles.

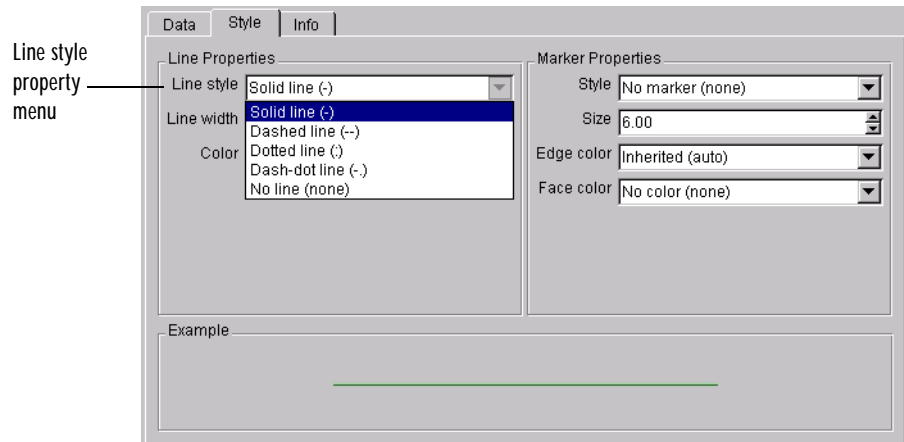

### Editing Multiple Objects

If you select multiple objects of the same type, the Property Editor displays the set of panels specific to that object type. For example, if you select several lines in a graph, the Property Editor displays the panels associated with line objects. If you change the value of a line property and apply your change, it affects all the objects you have selected.

If you select multiple objects of different types, for example, a line and an axes, the Property Editor displays only the **Info** panel, which provides access to properties that are common to all object types.

For information about navigating among multiple selections, see “Multiple Selections and the Navigation Bar” on page 1-20.

### Navigating Among Objects in a Graph

The navigation bar at the top of the Property Editor, labeled **Edit Properties for**, identifies the object being edited by its type (class) and tag, if the object’s tag property has a value. (A tag is a user-defined text string associated with an object.)

You can also use the navigation bar to select other objects, or groups of objects, in the graph that you want to edit. The following sections describe how to use the navigation bar.

- “Selecting Objects from the Navigation Bar” on page 1-19
- “Using the Navigation Bar To Search for Objects” on page 1-20
- “Multiple Selections and the Navigation Bar” on page 1-20

### Selecting Objects from the Navigation Bar

To edit one of the other objects in the graph:

- 1 Click on the navigation bar menu. The Property Editor displays a hierarchical list of all the objects in the current figure. (The Property Editor includes other figures that may be open in the list but does not include the child objects of these figures.)

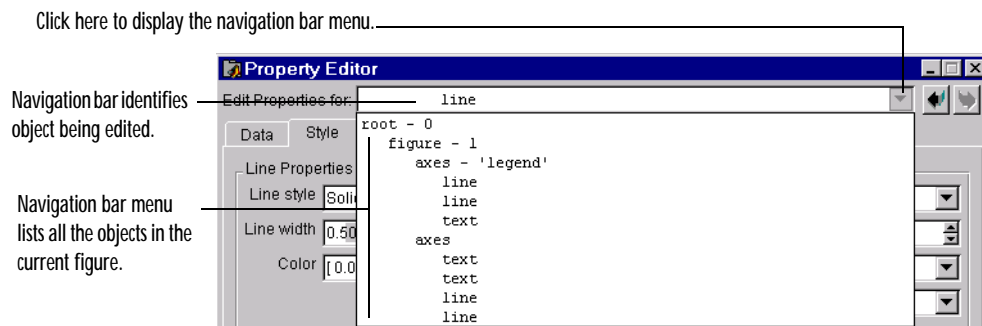

- 2 Select the object you want to edit from this list. The Property Editor displays the set of panels associated with the type of object you have selected. See “Identifying Objects in a Graph” on page 1-20 for more information.

---

**Note** Only objects that have their `HandleVisibility` property set to `On` appear in the navigation bar hierarchical list. However, objects appear in the navigation bar even if their `Visibility` property is set to `Off`.

---

## Using the Navigation Bar To Search for Objects

You can use the navigation bar to search for a particular object, or group of objects, in a figure by a tag, type (class), or handle.

For example, to edit every line in a figure, enter the text string `line` in the navigation bar. The Property Editor displays the set of property panels associated with line objects and lists all the lines in the navigation bar. Individual line objects are identified by their tags, if present.

## Multiple Selections and the Navigation Bar

When you select multiple objects, the Property Editor's navigation bar displays the objects' ancestors and children if the objects share a common parent. The Property Editor displays all the children in a single, non-hierarchical list. If you select objects that do not have a common parent, the Property Editor navigation bar only displays the selected objects.

For example, if you create a graph containing multiple line plots and you select several of the lines, the Property Editor's navigation bar display looks like this.

Navigation bar identifies objects being edited.

Navigation bar lists the selected objects and their common parents.

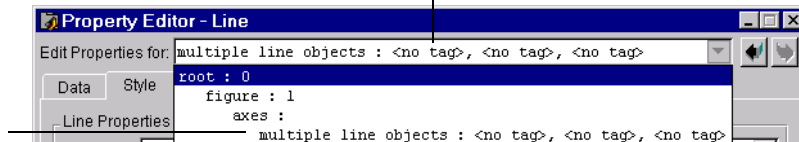

## Identifying Objects in a Graph

In the hierarchical display of the navigation bar, the Property Editor lists all the objects in a graph by their type and tag, if the object has a tag.

If a graph contains numerous line objects, tags can help identify which line object listed in the navigation bar list represents which line in the graph.

To create a tag for a particular object in a graph:

- 1 Double-click on the object in the graph. Plot editing mode must be enabled.



- 2 Click on the **Info** tab in the Property Editor.
- 3 Enter a text string in the **Tag** field that identifies the object in the graph.
- 4 Click **Apply**.

The Property Editor immediately updates the navigation bar display with the tag value.

## Applying Your Changes

To apply your changes, click the **Apply** button.

If you have checked the **Immediate Apply** box, your changes will appear automatically; you do not need to click on the **Apply** button.

If you make changes to fields on a panel and then attempt to switch panels without applying your changes, the Property Editor displays a warning message, asking you if you want to apply your changes before moving.

If you click **OK**, you apply your changes and dismiss the Property Editor.

---

**Note** During an editing session, keep the Property Editor open. Throughout the session, you can edit the properties of any object in your graph without restarting the Property Editor.

---

## Canceling Changes

If you have changed the values of properties and decide not to apply the changes, click on the **Revert** button. The **Revert** button resets all the properties to their values at the last **Apply**.

To reset a property value change and close the Property Editor, click the **Cancel** button.

## Using the Data Statistics Tool

The Data Statistics tool:

- Calculates basic statistics about the central tendency and variability of data plotted in a graph
- Plots any of the statistics in a graph.

When you select **Data Statistics** from the MATLAB figure window **Tools** menu, MATLAB calculates the statistics for each data set plotted in the graph and displays the results in the **Data Statistics** dialog box.

Identifies the figure in which the data is plotted.

Identifies the data set for which statistics have been calculated.

Lists the statistics calculated for both the x- and y-data that define the plot.

To add a plot of a statistic to a graph, click in the check box next to the value.

Click here to create workspace variables of the statistics.

	X		Y	
min	1790	<input type="checkbox"/>	3.9	<input type="checkbox"/>
max	1990	<input type="checkbox"/>	248.7	<input type="checkbox"/>
mean	1890	<input type="checkbox"/>	85.73	<input checked="" type="checkbox"/>
median	1890	<input type="checkbox"/>	62.9	<input type="checkbox"/>
std	62.05	<input type="checkbox"/>	78.6	<input type="checkbox"/>
range	200		244.8	

## Adding Plots of Statistics to a Graph

To plot a statistic in a graph, click in the check box next to its value. “Adding Plots of Data Statistics to a Graph” in the “Formatting Graphs” chapter provides an example of using the Data Statistics tool.

## **Saving Statistics to the Workspace**

To save a set of statistics as a workspace variable, click on the **Save to workspace...** button. The Data Statistics tool saves the statistics as a structure.



# Basic Plotting

---

<b>Basic Plotting Commands</b> . . . . .	2-2
Creating Plots . . . . .	2-2
Specifying Line Style . . . . .	2-4
Specifying the Color and Size of Lines . . . . .	2-6
Adding Plots to an Existing Graph . . . . .	2-7
Plotting Only the Data Points . . . . .	2-8
Plotting Markers and Lines . . . . .	2-9
Line Styles for Black and White Output . . . . .	2-10
Setting Default Line Styles . . . . .	2-11
<b>Line Plots of Matrix Data</b> . . . . .	2-13
<b>Plotting Imaginary and Complex Data</b> . . . . .	2-15
<b>Plotting with Two Y-Axes</b> . . . . .	2-16
Combining Linear and Logarithmic Axes . . . . .	2-16
<b>Setting Axis Parameters</b> . . . . .	2-19
Axis Limits and Ticks . . . . .	2-19
Example – Specifying Ticks and Tick Labels . . . . .	2-22
Setting Aspect Ratio . . . . .	2-24
<b>Figure Windows</b> . . . . .	2-26
Displaying Multiple Plots per Figure . . . . .	2-26
Specifying the Target Axes . . . . .	2-28
Default Color Scheme . . . . .	2-28

## Basic Plotting Commands

MATLAB<sup>®</sup> provides a variety of functions for displaying vector data as line plots, as well as functions for annotating and printing these graphs. The following table summarizes the functions that produce basic line plots. These functions differ in the way they scale the plot's axes. Each accepts input in the form of vectors or matrices and automatically scales the axes to accommodate the data.

Function	Description
plot	Graph 2-D data with linear scales for both axes
plot3	Graph 3-D data with linear scales for both axes
loglog	Graph with logarithmic scales for both axes
semilogx	Graph with a logarithmic scale for the $x$ -axis and a linear scale for the $y$ -axis
semilogy	Graph with a logarithmic scale for the $y$ -axis and a linear scale for the $x$ -axis
plotyy	Graph with $y$ -tick labels on the left and right side

### Creating Plots

The `plot` function has different forms depending on the input arguments. For example, if  $y$  is a vector, `plot(y)` produces a linear graph of the elements of  $y$  versus the index of the elements of  $y$ . If you specify two vectors as arguments, `plot(x,y)` produces a graph of  $y$  versus  $x$ .

For example, these statements create a vector of values in the range  $[0, 2\pi]$  in increments of  $\pi/100$  and then use this vector to evaluate the sine function over that range. MATLAB plots the vector on the  $x$ -axis and the value of the sine function on the  $y$ -axis.

```
t = 0:pi/100:2*pi;  
y = sin(t);  
plot(t,y)  
grid on
```

**MATLAB automatically selects appropriate axis ranges and tick mark locations.**

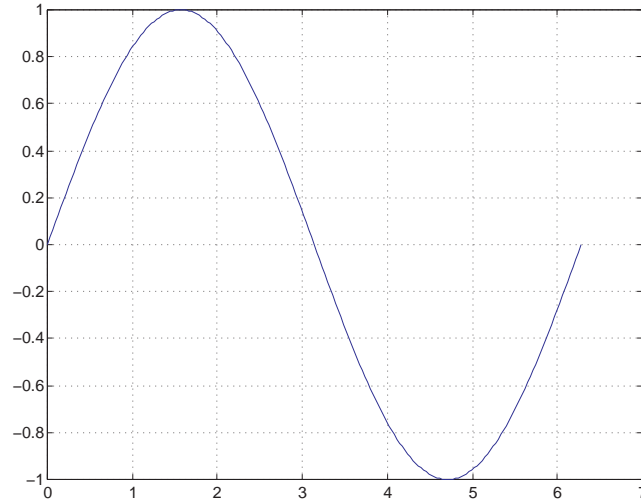

**You can plot multiple graphs in one call to `plot` using  $x$ - $y$  pairs. MATLAB automatically cycles through a predefined list of colors to allow discrimination between each set of data. Plotting three curves as a function of  $t$  produces**

```
y2 = sin(t-0.25);  
y3 = sin(t-0.5);  
plot(t,y,t,y2,t,y3)
```

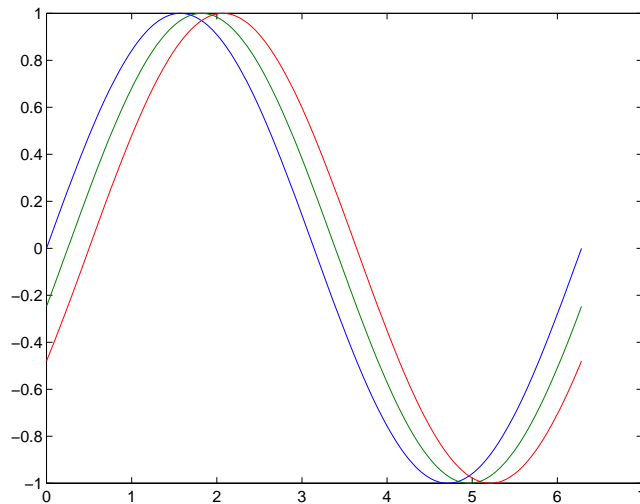

### Specifying Line Style

You can assign different line styles to each data set by passing line style identifier strings to `plot`. For example,

```
t = 0:pi/100:2*pi;  
y = sin(t);  
y2 = sin(t-0.25);  
y3 = sin(t-0.5);  
plot(t,y, '-',t,y2, '--',t,y3, ':')
```



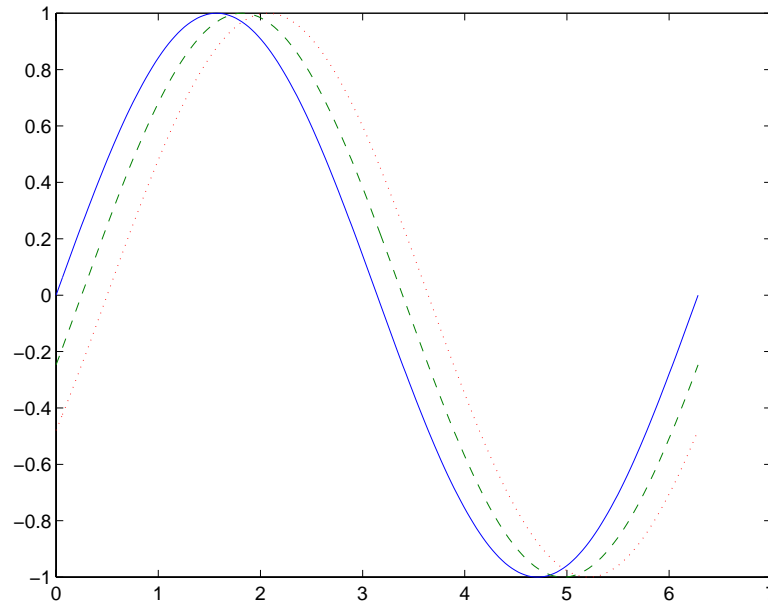

### Colors, Line Styles, and Markers

The basic plotting functions accepts character-string arguments that specify various line styles, marker symbols, and colors for each vector plotted. In the general form,

```
plot(x,y,'linestyle_marker_color')
```

*linestyle\_marker\_color* is a character string (delineated by single quotation marks) constructed from:

- A line style (e.g., dashed, dotted, etc.)
- A marker type (e.g., x, \*, o, etc.)
- A predefined color specifier (c, m, y, k, r, g, b, w)

For example,

```
plot(x,y,':squarey')
```

plots a yellow dotted line and places square markers at each data point. If you specify a marker type, but not a line style, MATLAB draws only the marker.

The specification can consist of one or none of each specifier in any order. For example, the string,

```
'go--'
```

defines a dashed line with circular markers, both colored green.

You can also specify the size of the marker and, for markers that are closed shapes, you can specify separately the color of the edges and the face.

See the `LineStyleSpec` discussion for more information.

## Specifying the Color and Size of Lines

You can control a number of line style characteristics by specifying values for line properties:

- `LineWidth` – specifies the width of the line in units of points.
- `MarkerEdgeColor` – specifies the color of the marker or the edge color for filled markers (circle, square, diamond, pentagram, hexagram, and the four triangles).
- `MarkerFaceColor` – specifies the color of the face of filled markers.
- `MarkerSize` – specifies the size of the marker in units of points.

For example, these statements,

```
x = -pi:pi/10:pi;  
y = tan(sin(x)) - sin(tan(x));  
plot(x,y,'--rs','LineWidth',2,...  
      'MarkerEdgeColor','k',...  
      'MarkerFaceColor','g',...  
      'MarkerSize',10)
```

produce a graph with:

- A red dashed line with square markers
- A line width of two points
- The edge of the marker colored black
- The face of the marker colored green
- The size of the marker set to 10 points

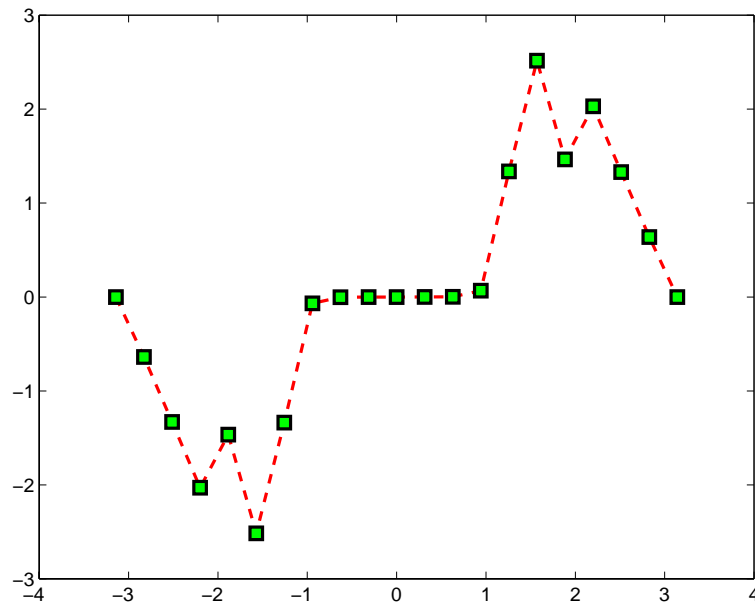

## Adding Plots to an Existing Graph

You can add plots to an existing graph using the `hold` command. When you set `hold` to on, MATLAB does not remove the existing graph; it adds the new data to the current graph, rescaling if the new data falls outside the range of the previous axis limits.

For example, these statements first create a semilogarithmic plot, then add a linear plot.

```
semilogx(1:100, '+')
hold on
plot(1:3:300, 1:100, '--')
hold off
```

While MATLAB resets the  $x$ -axis limits to accommodate the new data, it does not change the scaling from logarithmic to linear.

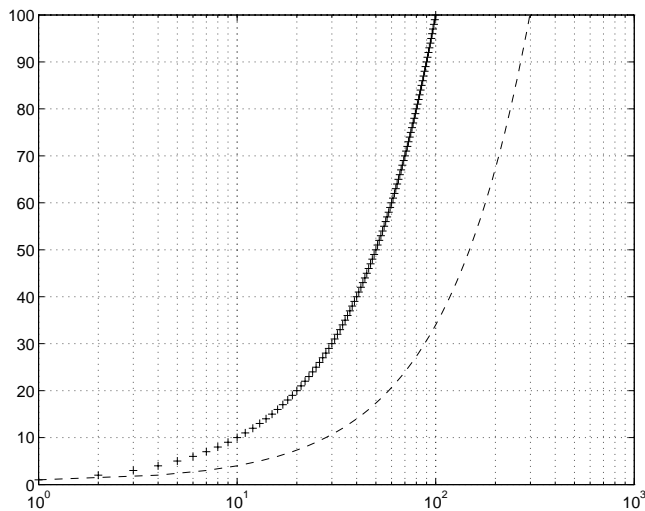

### Plotting Only the Data Points

To plot a marker at each data point without connecting the markers with lines, use a specification that does not contain a line style. For example, given two vectors,

```
x = 0:pi/15:4*pi;  
y = exp(2*cos(x));
```

calling `plot` with only a color and marker specifier

```
plot(x,y, 'r+')
```

plots a red plus sign at each data point.

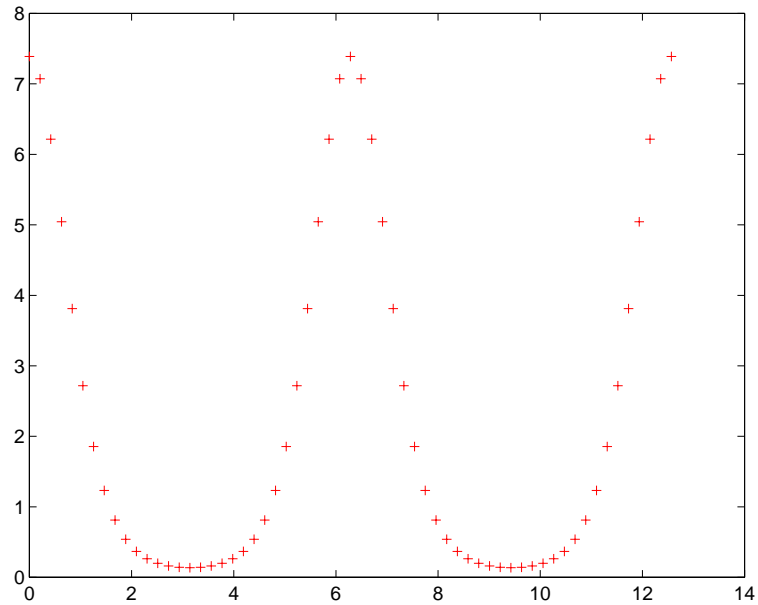

See `LineStyle` for a list of available line styles, markers, and colors.

## Plotting Markers and Lines

To plot both markers and the lines that connect them, specify a line style and a marker type. For example, the following command plots the data as a red, solid line and then adds circular markers with black edges at each data point.

```
x = 0:pi/15:4*pi;  
y = exp(2*cos(x));  
plot(x,y, '-r',x,y, 'ok')
```

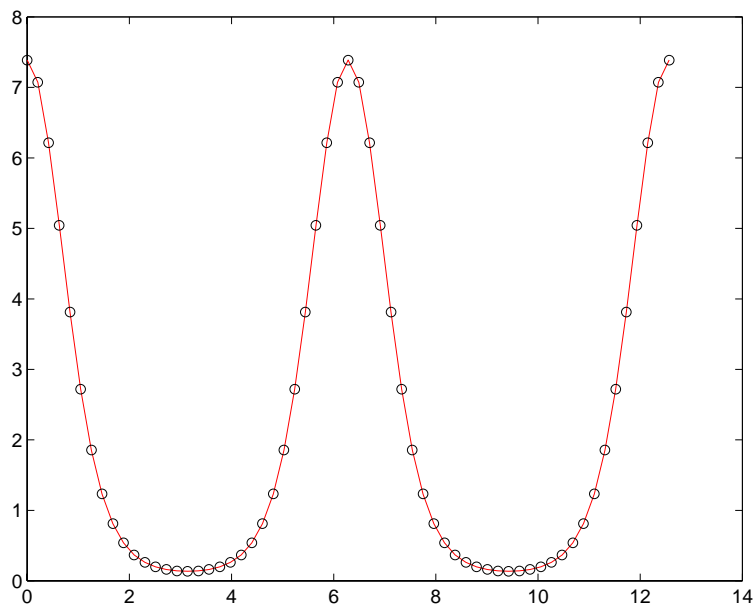

### Line Styles for Black and White Output

Line styles and markers enable you to discriminate different plots on the same graph when color is not available. For example, the following statements create a graph using a solid ('-k') line with asterisk markers colored black and a dash-dot ('-.ok') line with circular markers colored black.

```
x = 0:pi/15:4*pi;  
y1 = exp(2*cos(x));  
y2 = exp(2*sin(x));  
plot(x,y1,'-k',x,y2,'-.ok')
```

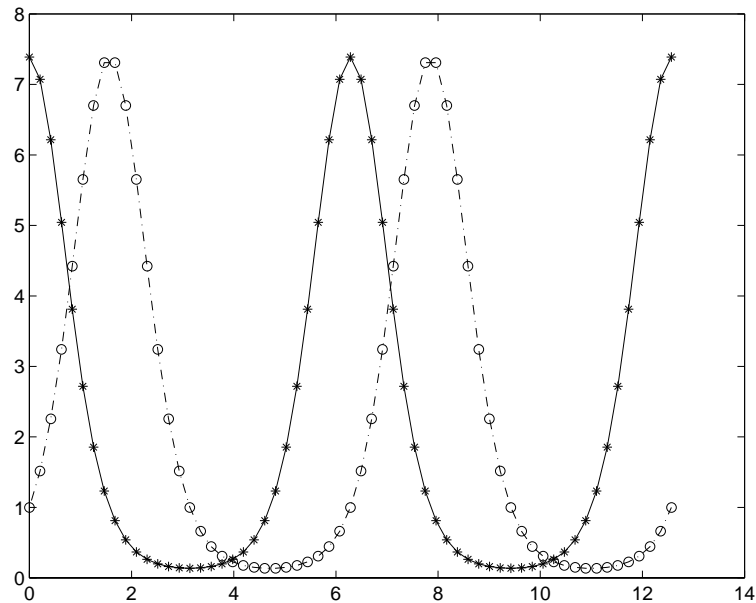

## Setting Default Line Styles

You can configure MATLAB to use line styles instead of colors for multi-line plots by setting a default value for the axes `LineStyleOrder` property. For example, the command,

```
set(0,'DefaultAxesLineStyleOrder',{'-o','s','--+'})
```

defines three line styles and makes them the default for all plots.

To set the default line color to dark gray, use the statement

```
set(0,'DefaultAxesColorOrder',[0.4,0.4,0.4])
```

See `ColorSpec` for information on how to specify color as a three-element vector of RGB values.

Now the plot command uses the line styles and colors you have defined as defaults. For example, these statements create a multiline plot.

```
x = 0:pi/10:2*pi;
y1 = sin(x);
```

```
y2 = sin(x-pi/2);  
y3 = sin(x-pi);  
plot(x,y1,x,y2,x,y3)
```

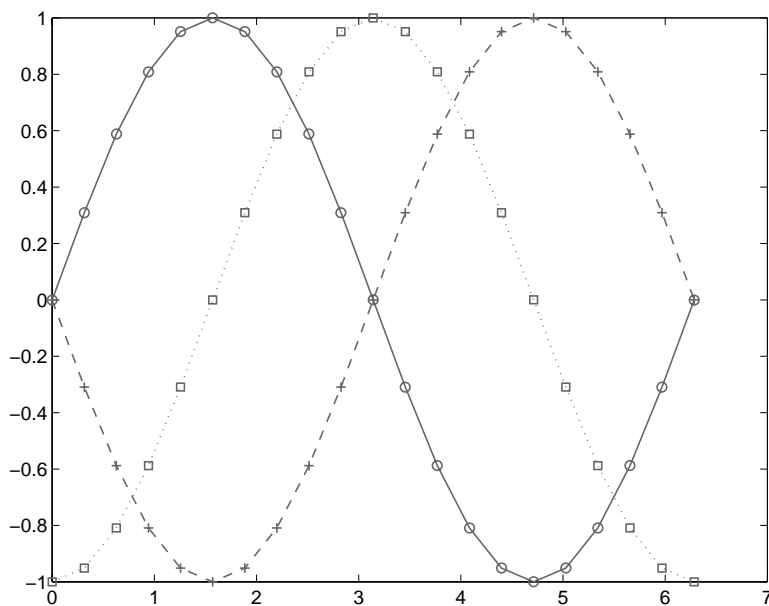

The default values persist until you quit MATLAB. To remove default values during your MATLAB session, use the reserved word `remove`.

```
set(0,'DefaultAxesLineStyleOrder','remove')  
set(0,'DefaultAxesColorOrder','remove')
```

See “Setting Default Property Values” in the “Handle Graphics Objects” chapter for more information.



## Line Plots of Matrix Data

When you call the `plot` function with a single matrix argument

```
plot(Y)
```

MATLAB draws one line for each column of the matrix. The  $x$ -axis is labeled with the row index vector,  $1:m$ , where  $m$  is the number of rows in  $Y$ . For example,

```
Z = peaks;
```

returns a 49-by-49 matrix obtained by evaluating a function of two variables. Plotting this matrix

```
plot(Z)
```

produces a graph with 49 lines.

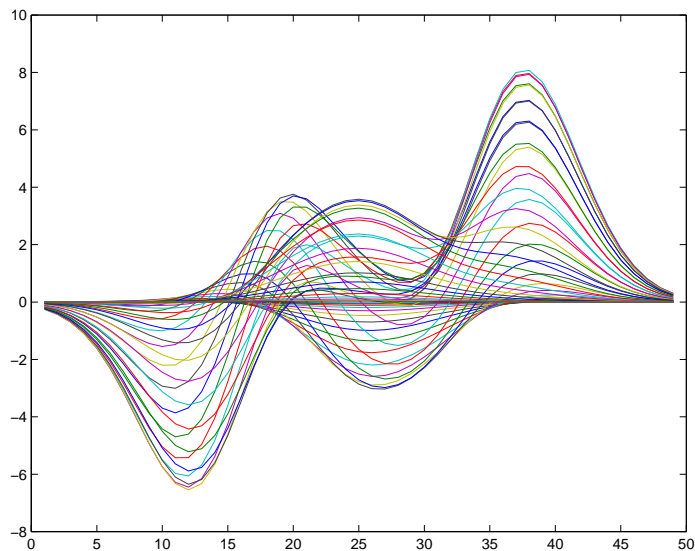

In general, if `plot` is used with two arguments and if either  $X$  or  $Y$  has more than one row or column, then

- If  $Y$  is a matrix, and  $x$  is a vector, `plot(x, Y)` successively plots the rows or columns of  $Y$  versus vector  $x$ , using different colors or line types for each. The

row or column orientation varies depending on whether the number of elements in  $x$  matches the number of rows in  $Y$  or the number of columns. If  $Y$  is square, its columns are used.

- If  $X$  is a matrix and  $y$  is a vector, `plot(X,y)` plots each row or column of  $X$  versus vector  $y$ . For example, plotting the peaks matrix versus the vector `1:length(peaks)` rotates the previous plot.

```
y = 1:length(peaks);  
plot(peaks,y)
```

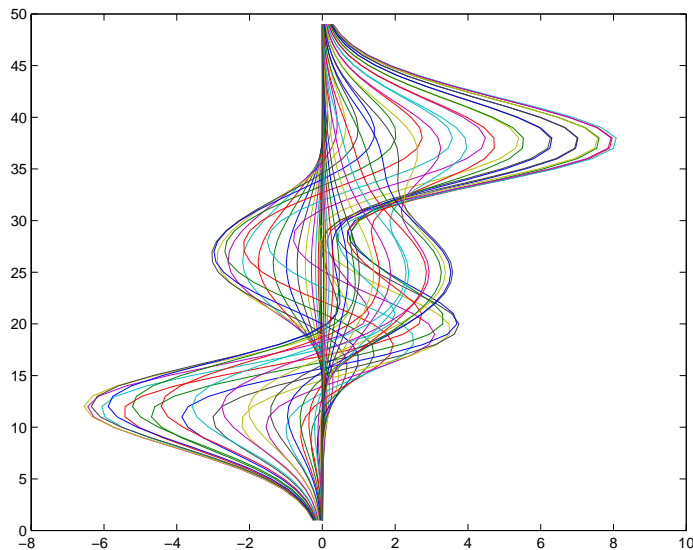

- If  $X$  and  $Y$  are both matrices of the same size, `plot(X,Y)` plots the columns of  $X$  versus the columns of  $Y$ .

You can also use the `plot` function with multiple pairs of matrix arguments.

```
plot(X1,Y1,X2,Y2,...)
```

This statement graphs each  $X$ - $Y$  pair, generating multiple lines. The different pairs can be of different dimensions.

## Plotting Imaginary and Complex Data

When the arguments to `plot` are complex (i.e., the imaginary part is nonzero), MATLAB ignores the imaginary part *except* when `plot` is given a single complex argument. For this special case, the command is a shortcut for a plot of the real part versus the imaginary part. Therefore,

```
plot(Z)
```

where  $Z$  is a complex vector or matrix, is equivalent to

```
plot(real(Z), imag(Z))
```

For example, this statement plots the distribution of the eigenvalues of a random matrix using circular markers to indicate the data points.

```
plot(eig(randn(20,20)), 'o', 'MarkerSize', 6)
```

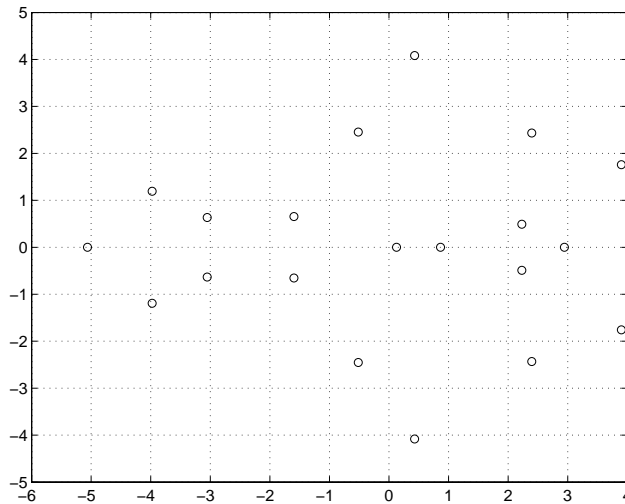

To plot more than one complex matrix, there is no shortcut; the real and imaginary parts must be taken explicitly.

## Plotting with Two Y-Axes

The `plotyy` command enables you to create plots of two data sets and use both left and right side  $y$ -axes. You can also apply different plotting functions to each data set. For example, you can combine a line plot with a stem plot of the same data.

```
t = 0:pi/20:2*pi;
y = exp(sin(t));
plotyy(t,y,t,y,'plot','stem')
```

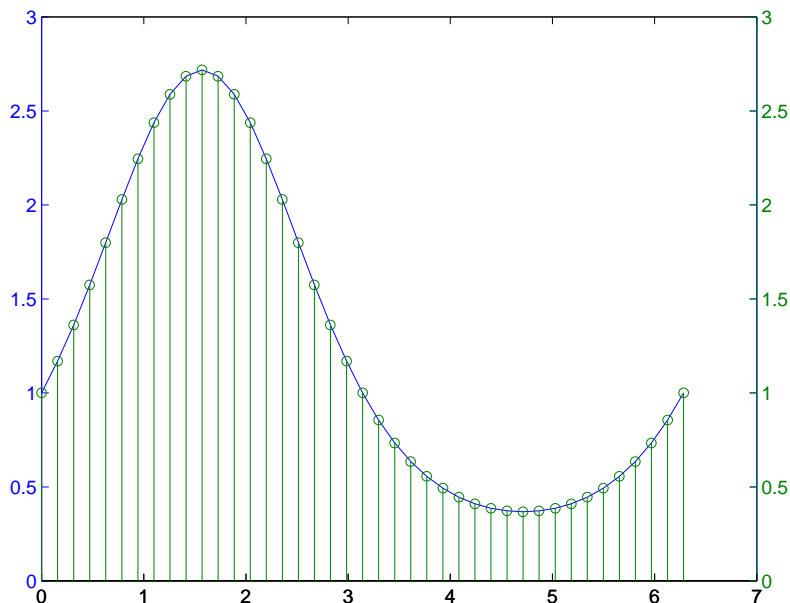

## Combining Linear and Logarithmic Axes

You can use `plotyy` to apply linear and logarithmic scaling to compare two data sets having a different range of values.

```
t = 0:900; A = 1000; a = 0.005; b = 0.005;
z1 = A*exp(-a*t);
z2 = sin(b*t);
[haxes,hline1,hline2] = plotyy(t,z1,t,z2,'semilogy','plot');
```

This example saves the handles of the lines and axes created to adjust and label the graph. First, label the axes whose  $y$  value ranges from 10 to 1000. This is the first handle in `haxes` because we specified this plot first in the call to `plotyy`. Use the `axes` command to make `haxes(1)` the current axes, which is then the target for the `ylabel` command.

```
axes(haxes(1))  
ylabel('Semilog Plot')
```

Now make the second axes current and call `ylabel` again.

```
axes(haxes(2))  
ylabel('Linear Plot')
```

You can modify the characteristics of the plotted lines in a similar way. For example, to change the line style of the second line plotted to a dashed line, use the statement

```
set(hline2, 'LineStyle', '--')
```

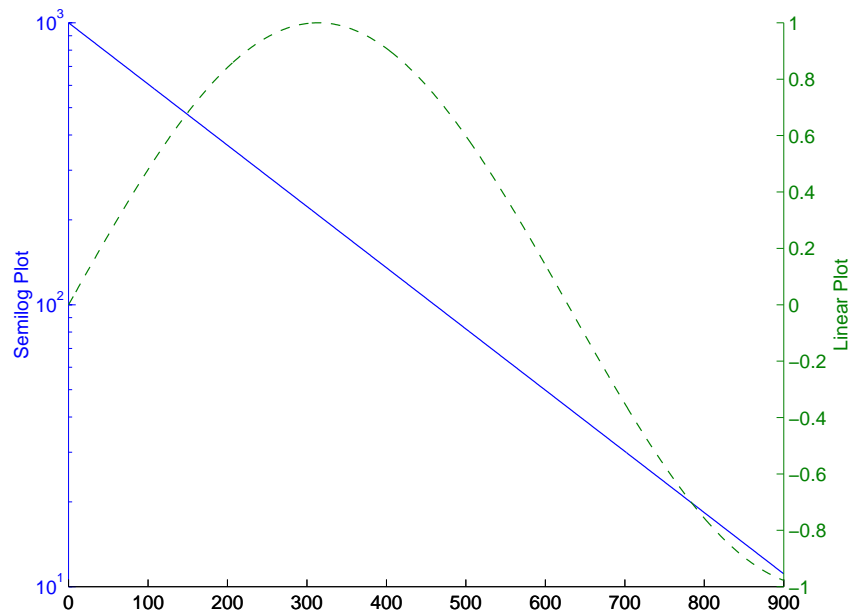

See “Using Multiple X and Y Axes” in the “Axes Properties” chapter for an example that employs double  $x$ - and  $y$ -axes.

See `LineStyle` for additional line properties.

## Setting Axis Parameters

When you create a graph, MATLAB automatically selects the axis limits and tick-mark spacing based on the data plotted. However, you can specify your own values for axis limits and tick marks by overriding MATLAB's values. You can do this with the following commands:

- `axis` – sets values that affect the current axes object (the most recently created or the last clicked on).
- `axes` – (not `axis`) creates a new axes object with the specified characteristics.
- `get` and `set` – enable you to query and set a wide variety of properties of existing axes.
- `gca` – returns the handle (identifier) of the current axes. If there are multiple axes in the figure window, the current axes is the last graph created or the last graph you clicked on with the mouse.

### Related Information

See the chapter “Defining the View” for more extensive information on manipulating 3-D views.

## Axis Limits and Ticks

MATLAB selects axis limits based on the range of the plotted data. You can specify the limits manually using the `axis` command. Call `axis` with the new limits defined as a four-element vector.

```
axis([xmin,xmax,ymin,ymax])
```

Note that the minimum values must be less than the maximum values.

### Semiautomatic Limits

If you want MATLAB to autoscale only one of a min/max set of axis limits, but you want to specify the other, use the MATLAB variable `Inf` or `-Inf` for the autoscaled limit. For example, this graph uses default scaling.

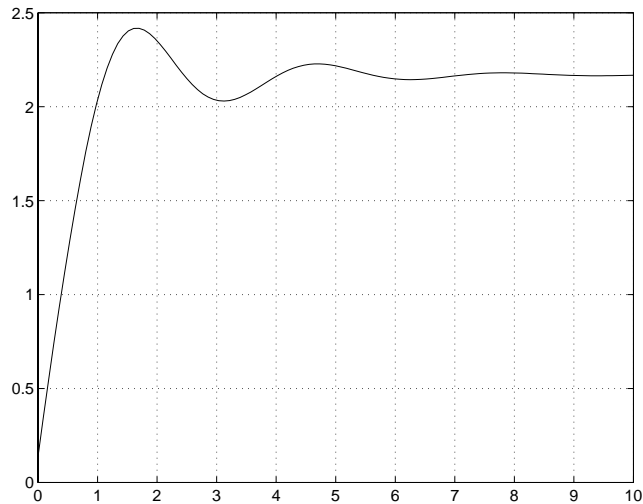

Compare the default limits to the following graph, which sets the maximum limit of the  $x$ -axis, but autoscales the minimum limit.

```
axis([-Inf 5 2 2.5])
```



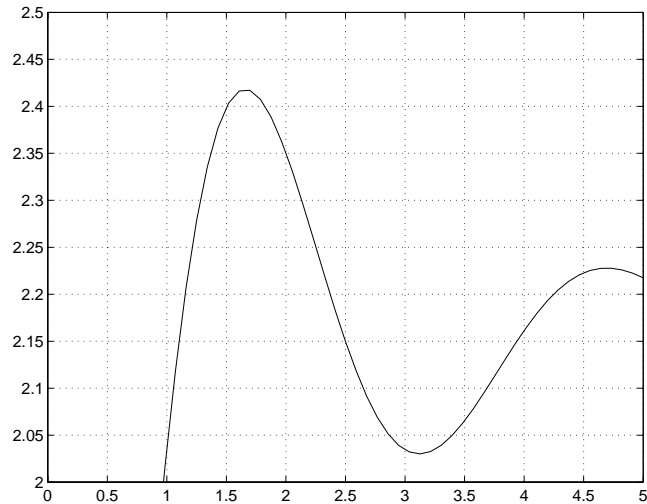

### Axis Tick Marks

MATLAB selects the tick mark locations based on the range of data so as to produce equally spaced ticks (for linear graphs). You can specify different tick marks by setting the axes `XTick` and `YTick` properties. Define tick marks as a vector of increasing values. The values do not need to be equally spaced.

For example, setting the *y*-axis tick marks for the graph from the preceding example,

```
set(gca, 'ytick', [2 2.1 2.2 2.3 2.4 2.5])
```

produces a graph with only the specified ticks on the *y*-axis.

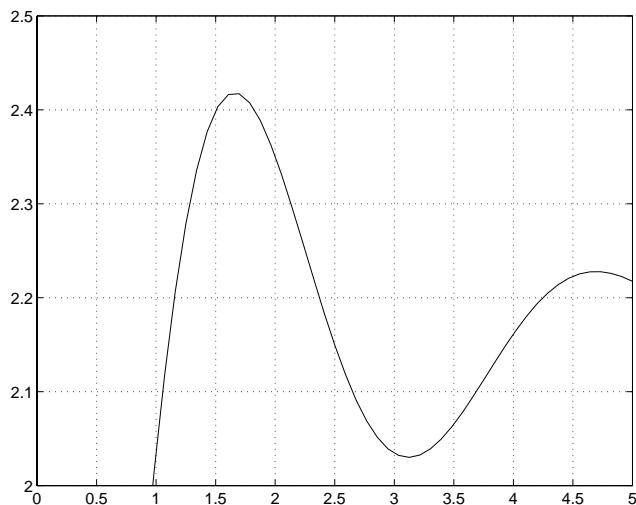

Note that if you specify tick mark values that are outside the axis limits, MATLAB does not display them (that is, specifying tick marks cannot cause axis limits to change).

### Example – Specifying Ticks and Tick Labels

You can adjust the axis tick-mark locations and the labels appearing at each tick mark. For example, this plot of the sine function relabels the x-axis with more meaningful values.

```
x = -pi:.1:pi;
y = sin(x);
plot(x,y)
set(gca,'XTick',-pi:pi/2:pi)
set(gca,'XTickLabel',{'-pi','-pi/2','0','pi/2','pi'})
```

These commands (`xlabel`, `ylabel`, `title`, `text`) add axis labels and draw an arrow that points to the location on the graph where  $y = \sin(-\pi/4)$ .

```
xlabel('-\pi \leq \theta \leq \pi')
ylabel('sin(\theta)')
```

```

title('Plot of sin(\Theta)')
text(-pi/4,sin(-pi/4),'\leftarrow sin(-\pi\div4)',...
     'HorizontalAlignment','left')

```

### Setting Line Properties on an Existing Plot

Change the line color to purple by first finding the handle of the line object created by `plot` and then setting its `Color` property. Use `findobj` and the fact that MATLAB creates a blue line (RGB value `[0 0 1]`) by default. In the same statement, set the `LineWidth` property to 2 points.

```

set(findobj(gca,'Type','line','Color',[0 0 1]),...
    'Color',[0.5,0,0.5],'LineWidth',2)

```

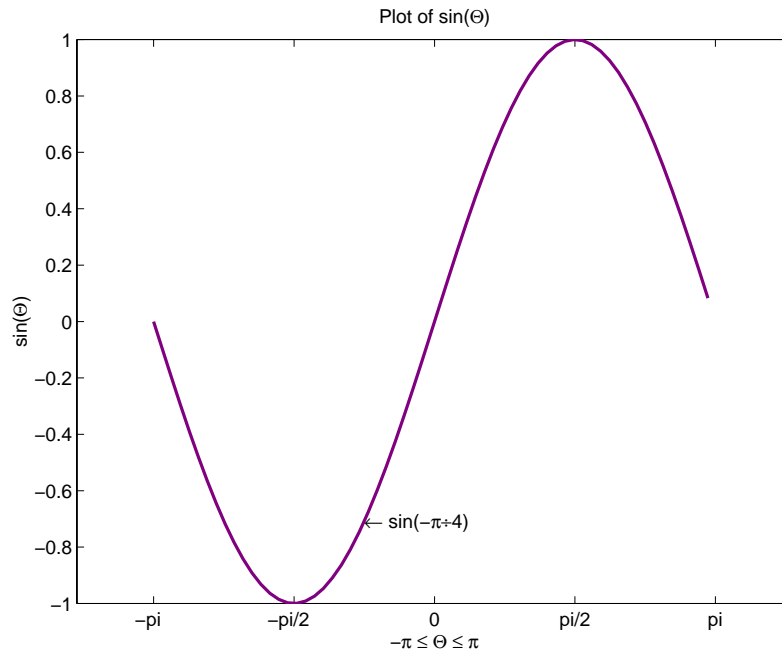

The Greek symbols are created using TeX character sequences.

## Setting Aspect Ratio

By default, MATLAB displays graphs in a rectangular axes that has the same aspect ratio as the figure window. This makes optimum use of space available for plotting. MATLAB provides control over the aspect ratio with the `axis` command.

For example,

```
t = 0:pi/20:2*pi;  
plot(sin(t),2*cos(t))  
grid on
```

produces a graph with the default aspect ratio. The command

```
axis square
```

makes the  $x$ - and  $y$ -axes equal in length.

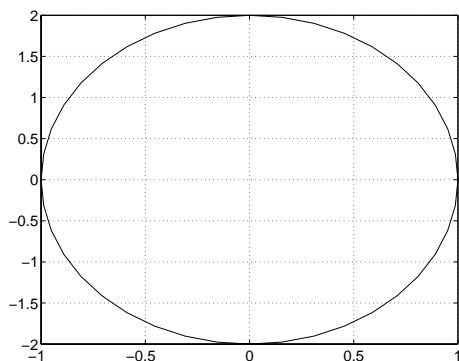

axis normal

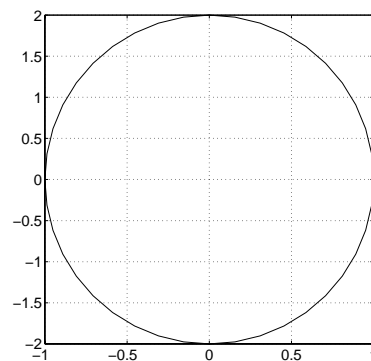

axis square

The square axes has one data unit in  $x$  to equal two data units in  $y$ . If you want the  $x$ - and  $y$ -data units to be equal, use the command

```
axis equal
```

This produces an axes that is rectangular in shape, but has equal scaling along each axis.

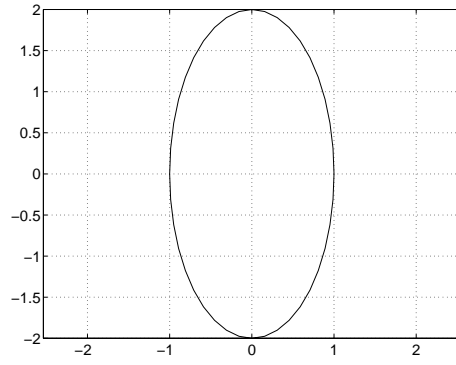

axis equal

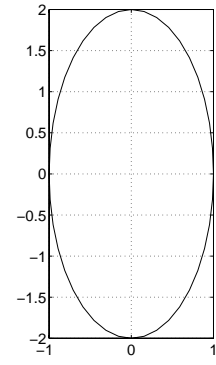

axis equal tight

If you want the axes shape to conform to the plotted data, use the `tight` option in conjunction with `equal`.

```
axis equal tight
```

## Figure Windows

MATLAB directs graphics output to a window that is separate from the command window. In MATLAB this window is referred to as a *figure*. The characteristics of this window are controlled by your computer's windowing system and MATLAB figure properties.

Graphics functions automatically create new figure windows if none currently exist. If a figure already exists, MATLAB uses that window. If multiple figures exist, one is designated as the *current figure* and is used by MATLAB (this is generally the last figure used or the last figure you clicked the mouse in).

The `figure` function creates figure windows. For example,

```
figure
```

creates a new window and makes it the current figure. You can make an existing figure current by clicking on it with the mouse or by passing its handle (the number indicated in the window title bar), as an argument to `figure`.

```
figure(h)
```

## Displaying Multiple Plots per Figure

You can display multiple plots in the same figure window and print them on the same piece of paper with the `subplot` function.

`subplot(m,n,i)` breaks the figure window into an  $m$ -by- $n$  matrix of small subplots and selects the  $i$ th subplot for the current plot. The plots are numbered along the top row of the figure window, then the second row, and so forth.

For example, the following statements plot data in four different subregions of the figure window.

```
t = 0:pi/20:2*pi;
[x,y] = meshgrid(t);

subplot(2,2,1)
plot(sin(t),cos(t))
axis equal
```

```
subplot(2,2,2)
z = sin(x)+cos(y);
plot(t,z)
axis([0 2*pi -2 2])
```

```
subplot(2,2,3)
z = sin(x).*cos(y);
plot(t,z)
axis([0 2*pi -1 1])
```

```
subplot(2,2,4)
z = (sin(x).^2)-(cos(y).^2);
plot(t,z)
axis([0 2*pi -1 1])
```

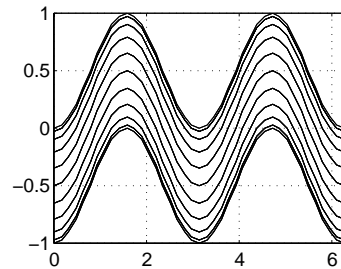
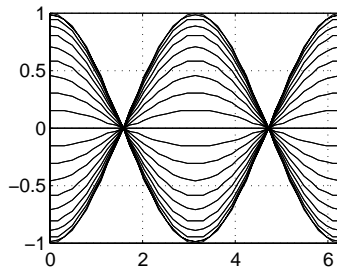
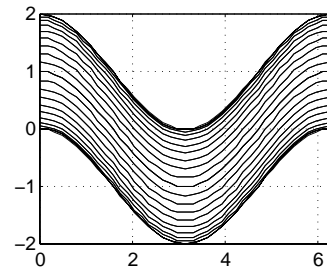
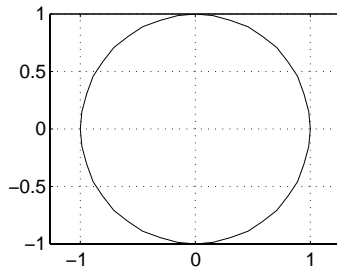

Each subregion contains its own axes with characteristics you can control independently of the other subregions. This example uses the `axis` command to set limits and change the shape of the subplots.

See the `axes`, `axis`, and `subplot` functions for more information.

## Specifying the Target Axes

The current axes is the last one defined by `subplot`. If you want to access a previously defined subplot, for example to add a title, you must first make that axes current.

You can make an axes current in three ways:

- Click on the subplot with the mouse
- Call `subplot` the `m`, `n`, `i` specifiers
- Call `subplot` with the handle (identifier) of the axes

For example,

```
subplot(2,2,2)
title('Top Right Plot')
```

adds a title to the plot in the upper-right side of the figure.

You can obtain the handles of all the subplot axes with the statement

```
h = get(gcf, 'Children');
```

MATLAB returns the handles of all the axes, with the most recently created one first. That is, `h(1)` is subplot 224, `h(2)` is subplot 223, `h(3)` is subplot 222, and `h(4)` is subplot 221. For example, to replace subplot 222 with a new plot, first make it the current axes with

```
subplot(h(3))
```

## Default Color Scheme

The default figure color scheme produces good contrast and visibility for the various graphics functions. This scheme defines colors for the window background, the axis background, the axis lines and labels, the colors of the lines used for plotting and surface edges, and other properties that affect appearance.



The `colordef` function enables you to select from predefined color schemes and to modify colors individually. `colordef` predefines three color schemes:

- `colordef white` – sets the axis background color to white, the window background color to gray, the colormap to `jet`, surface edge colors to black, and defines appropriate values for the plotting color order and other properties.
- `colordef black` – sets the axis background color to black, the window background color to dark gray, the colormap to `jet`, surface edge colors to black, and defines appropriate values for the plotting color order and other properties.
- `colordef none` – set the colors to match that of MATLAB 4. This is basically a black background with white axis lines and no grid. MATLAB programs that are based on the MATLAB 4 color scheme may need to call `colordef` with the `none` option to produce the expected results.

You can examine the `colordef.m` M-file to determine what properties it sets (enter type `colordef` at the MATLAB prompt).



# Formatting Graphs

---

<b>Overview</b> . . . . .	<b>3-2</b>
<b>Adding a Title to a Graph</b> . . . . .	<b>3-3</b>
<b>Adding a Legend to a Graph</b> . . . . .	<b>3-6</b>
<b>Adding Axes Labels to a Graph</b> . . . . .	<b>3-11</b>
<b>Adding Text Annotations to a Graph</b> . . . . .	<b>3-15</b>
<b>Adding Arrows and Lines to a Graph</b> . . . . .	<b>3-27</b>
<b>Adding Plots of Basic Statistics to a Graph</b> . . . . .	<b>3-29</b>

## Overview

When creating presentation graphics, you may want to add labels and annotations to your graph to help explain your data. MATLAB provides mechanisms that let you:

- Add a title at the top of an axes
- Add a legend
- Add labels to axes
- Add free-form text annotations anywhere on your graph
- Add arrows and lines anywhere on your graph
- Add plots of basic data statistics, such as the maximum, minimum, and mean

The following figure shows a graph that uses all of these labels and annotations. Click on any of the labels and annotations in this figure to get more information about how to create the label or annotation.

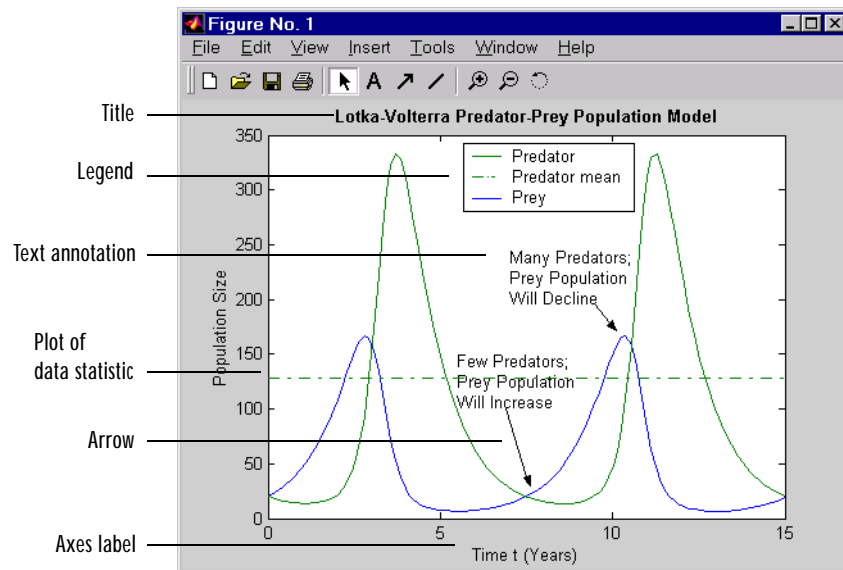

## Adding a Title to a Graph

In MATLAB, a title is a text string at the top of an axes. Titles typically define the subject of the graph.

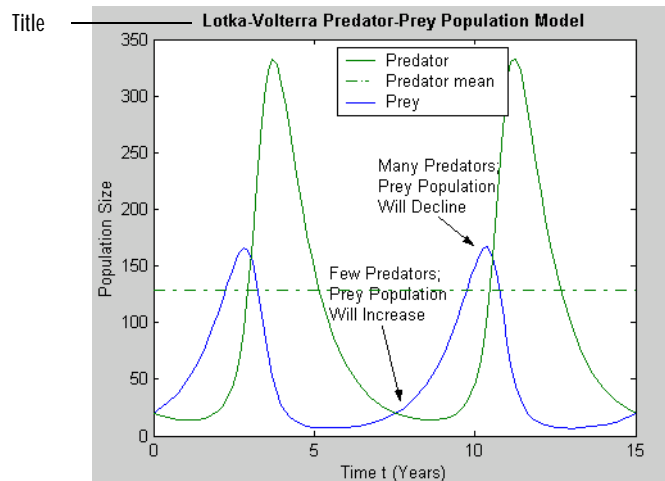

There are several ways to add a title to a graph:

- “Using the Title Option on the Insert Menu” on page 3-3
- “Using the Property Editor to Add a Title” on page 3-4
- “Using the title Function” on page 3-5

---

**Note** While you can use free-form text annotations to create a title for your graph, it is not recommended. Titles are anchored to the axes they describe; text annotations are not. If you move or resize your axes, the title automatically moves with the axes. Additionally, if you cut a title and then paste it back into a figure, the title will no longer be anchored to the axes.

---

### Using the Title Option on the Insert Menu

To add a title to a graph using the **Insert** menu:

- 1 Click the **Insert** menu in the Figure window menu bar and choose **Title**. MATLAB opens a text entry box at the top of the axes.

---

**Note** When you select the **Title** option, MATLAB enables plot editing mode automatically.

---

- 2 Enter the text of the label.
- 3 When you are finished entering text, click anywhere in the figure background to close the text entry box around the title. If you click on another object in the figure, such as an axes or line, you close the title text entry box but also automatically select the object you clicked on.

To change the font used in the title to bold, you must edit the title. You can edit the title as you would any other text object in a graph. See “Editing Text Annotations” on page 3-22 for more information.

### Using the Property Editor to Add a Title

To add a title to a graph using the Property Editor:

- 1 Start plot editing mode.
- 2 Double-click on the axes in the graph. This starts the Property Editor. You can also start the Property Editor by right-clicking on the axes and selecting **Properties** from the context menu.

In MATLAB Handle Graphics, titles are a property of axes objects. The Property Editor displays the set of property panels specific to axes objects.

- 3 Select the **Labels** panel and type in the text of your title in the Title text entry box.

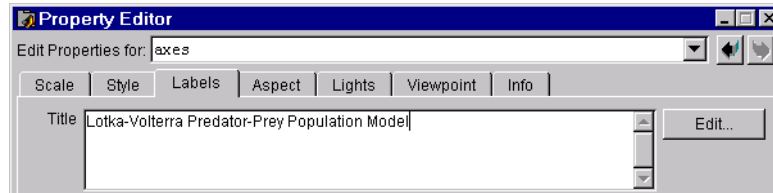

#### 4 Click **Apply**.

The title you create is a text object and, as such, you can change the font, font style, position and many other aspects of its format. To view the properties associated with a text object, click the **Edit** button next to the Title text entry box. For more information about text object properties, see “Editing Text Annotations” on page 3-22.

### Using the title Function

To add a title to a graph at the MATLAB command prompt or from an M-file, use the `title` function. The `title` function lets you specify the value of title properties at the time you create it.

For example, the following code adds a title to the current axes and sets the value of the `FontWeight` property to bold.

```
title('Lotka-Volterra Predator-Prey Population Model',...  
      'FontWeight','bold')
```

To edit a title from the MATLAB command prompt or from an M-file, use the `set` function. See “Setting and Querying Object Properties” in the “Handle Graphics Objects” chapter for more information.

## Adding a Legend to a Graph

Legends identify each data set plotted in your graph. In a legend, MATLAB includes a small sample of the line or marker used to represent each data set in the graph, in the same color and style as it appears in the graph. MATLAB also includes a text label to identify each data set.

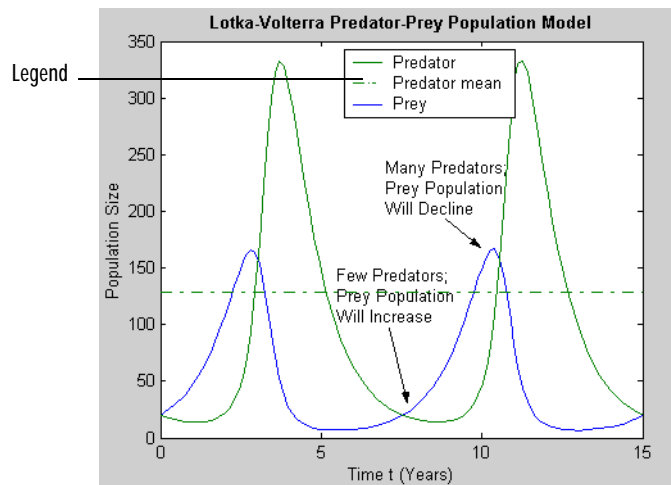

This section includes these topics:

- “Using the Legend Option on the Insert Menu” on page 3-7
- “Using the Legend Function” on page 3-7
- “Positioning a Legend” on page 3-8
- “Editing a Legend” on page 3-9
- “Removing a Legend” on page 3-10

---

**Note** The legend is implemented as a separate axes overlaying the axes it describes. The legend axes is not anchored to the main axes. If you resize or move the main axes, or create new subplots, you may need to reposition the legend.

---



## Using the Legend Option on the Insert Menu

To add a legend to a graph, click on the **Insert** menu and choose **Legend**. MATLAB creates a legend, placing it in the upper right corner of the plot.

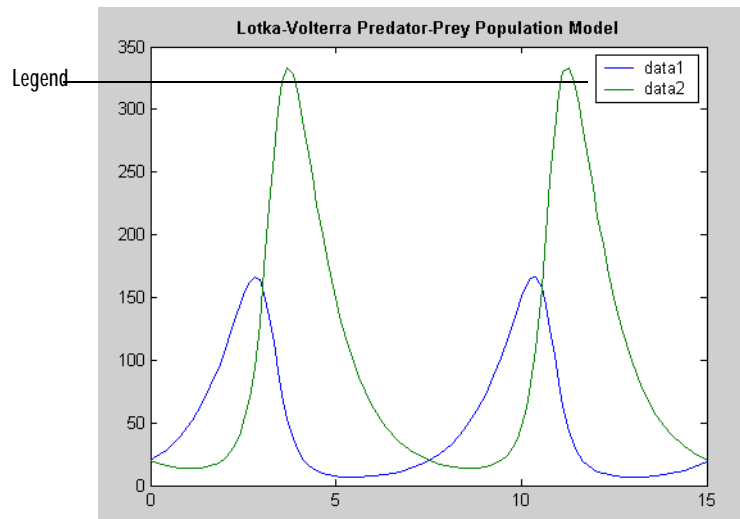

MATLAB creates text labels to identify each data set in the graph, using data1 to identify the first data set, data2 to identify the second data set, and so on. To learn how to customize a legend, such as changing its position or changing the text labels, see “Positioning a Legend” on page 3-8 and “Editing a Legend” on page 3-9.

## Using the Legend Function

To add a legend to a graph at the MATLAB command prompt or from an M-file, use the legend function. You must specify the text labels when you create a legend using the legend function.

For example, the following code adds a legend to the current axes.

```
legend('Y1 Predator', 'Y2 Prey')
```

The legend function lets you specify many other aspects of the legend, such as its position. For more information, see the legend function reference information.

### Positioning a Legend

There are two ways to change the position of a legend in a graph, depending on whether plot editing mode is enabled.

#### If Plot Editing Mode Is Not Enabled

- 1 Move the mouse over the legend and press and hold down the left mouse button. MATLAB changes the cursor to the indicate possible directions of movement.
- 2 With the mouse button still pressed, move the legend anywhere in the graph.
- 3 Release the mouse button.

#### If Plot Editing Mode Is Enabled

- 1 Right-click on the legend. This selects the legend and triggers the display of the context menu for the legend.
- 2 Select **Unlock Axes Position** from the context menu. (The legend is an axes object.)

---

**Note** If the context menu does not include the **Unlock Axes Position** option, you probably selected the text labels in the legend or the line objects and not the legend axes. Every object in a legend is individually selectable. Make sure you have selected the legend axes.

---

- 3 Move the cursor back over the legend axes (it should still be selected) and press and hold down either mouse button. MATLAB changes the cursor to indicate possible directions of movement.
- 4 Move the legend anywhere in the graph.
- 5 Release the mouse button.

## Editing a Legend

A legend is implemented as a separate axes object containing one or more line objects, representing samples of the plots in the graph, and one or more text objects, representing the labels for each data set plotted in a graph.

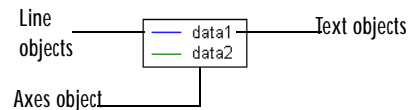

You can edit a legend when plot editing mode is enabled or when it is not enabled.

### Editing a Legend in Plot Editing Mode

When you enable plot editing mode, you can edit any of the objects that make up a legend as you would any other axes, line, or text object in a graph. For example, if you double-click on the legend axes, the Property Editor displays the set of property panels for axes objects. Change the value of an axes property and click **Apply**.

If you double-click on a text label in a legend, MATLAB opens a text editing box around all the text labels in the legend. You can edit any of the text labels in the legend. To access the properties of these text objects, right-click on a text label and select **Properties** from the context-sensitive pop-up menu.

### Editing a Legend When Plot Editing Mode Is Not Enabled

When plot editing mode is not enabled, you can still edit the text labels in a legend.

- 1 Double-click on a text label in the legend.

MATLAB opens a text edit box around the text label you selected. All the other text labels are temporarily hidden. You can only edit one text label at a time.

- 2 Make changes to the text label and then click anywhere in the figure outside of the text edit box when you are finished.

MATLAB automatically resizes the legend box to fit long or multiline labels.

### Resizing a Legend

To resize a legend:

- 1 Start plot editing mode.
- 2 Right-click on its axes and select **Unlock Axes Position** from the pop-up menu.
- 3 Move the cursor back to the legend axes, which is selected, and grab one of the selection handles. MATLAB changes the cursor to indicate possible directions.

---

**Note** If the text labels extend past the legend axes border, you cannot grab the selection handles on the right side of the legend axes. Resize the axes from the left side to fit the new text labels.

---

- 4 Drag the selection handle to resize the legend.

### Removing a Legend

If you have enabled plot editing mode, you can remove a legend by clicking on it and choosing the **Cut** option on the **Edit** menu. You can also remove a legend by right-clicking on it and selecting **Cut** from the context-sensitive pop-up menu.

If plot editing mode is not enabled, you can remove a legend by selecting the **Legend** option on the **Insert** menu. The **Legend** options acts as a toggle switch — selecting it alternately adds or removes a legend.

## Adding Axes Labels to a Graph

In MATLAB, an axes label is a text string aligned with the  $x$ -,  $y$ -, or  $z$ -axis in a graph. Axes labels can help explain the meaning of the units that each axis represents.

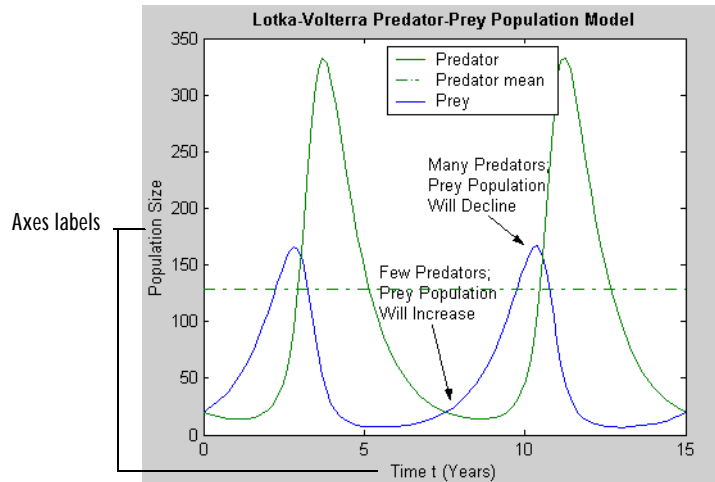

**Note** While you can use free-form text annotations to create axes labels, it is not recommended. Axes labels are anchored to the axes they describe; text annotations are not. If you move or resize your axes, the labels automatically move with the axes. Additionally, if you cut a label and then paste it back into a figure, the label will no longer be anchored to the axes.

To add axes labels to a graph, you can use any of these mechanisms:

- “Using the Label Options on the Insert Menu” on page 3-12
- “Using the Property Editor to Add Axes labels” on page 3-12
- “Using the Label Commands” on page 3-13

### Using the Label Options on the Insert Menu

- 1 Click on the **Insert** menu and choose the label option that corresponds to the axes you want to label: **X Label**, **Y Label**, or **Z Label**. MATLAB opens a text entry box along the axes, or around an existing axes label.

---

**Note** MATLAB opens up a horizontal text editing box for the Y- and Z- axes labels and automatically rotates the label into alignment with the axes when you finish entering text.

---

- 2 Enter the text of the label, or edit the text of an existing label.
- 3 Click anywhere else in the figure background to close the text entry box around the label. If you click on another object in the figure, such as an axes or line, you close the label text entry box but also automatically select the object you clicked on.

---

**Note** After you use the **Insert** menu to add an axes label, plot edit mode is enabled in the figure, if it was not already enabled.

---

### Using the Property Editor to Add Axes labels

To add labels to a graph using the Property Editor:

- 1 Start plot editing mode.
- 2 Start the Property Editor by either double-clicking on the axes in the graph or by right-clicking on the axes and selecting **Properties** from the context-sensitive pop-up menu.

The Property Editor displays the set of property panels specific to axes objects.

- 3 Select the **Labels** panel. Enter the text of the label in the appropriate text entry box.

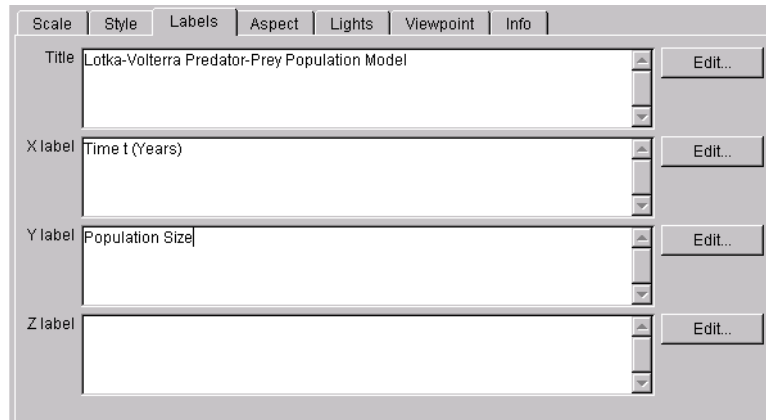

4 Click **Apply**.

## Using the Label Commands

You can add  $x$ -,  $y$ -, and  $z$ -axis labels using the `xlabel`, `ylabel`, and `zlabel` commands. For example, these statements label the axes and add a title.

```
xlabel('t = 0 to 2\pi','FontSize',16)
ylabel('sin(t)','FontSize',16)
title('\it{Value of the Sine from Zero to Two Pi}','FontSize',16)
```

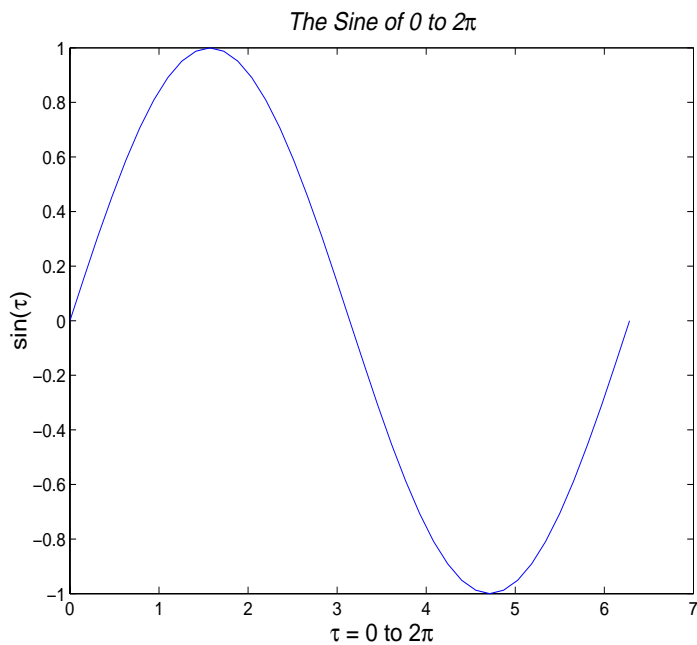

The labeling commands automatically position the text string appropriately. MATLAB interprets the characters immediately following the backslash “\” as TeX commands. These commands draw symbols such as Greek letters and arrows. See the text String property for a list of TeX character sequences.



## Adding Text Annotations to a Graph

You can add free-form text annotations anywhere in a MATLAB figure to help explain your data or bring attention to specific points in your data sets.

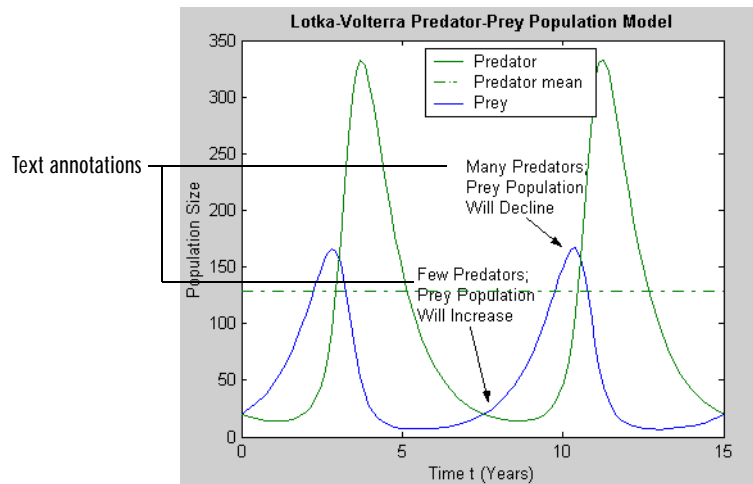

If you enable plot editing mode, you can create text annotations by clicking in an area of the graph or the figure background and entering text. You can also add text annotations from the command line, using the `text` or `gtext` command.

Using plot editing mode or `gtext` make it easy to place a text annotation anywhere in graph. Use the `text` command when you want to position a text annotation at a specific point in a data set.

---

**Note** Text annotations created using the `text` or `gtext` command are anchored to the axes. Text annotations created in plot edit mode are not. If you move or resize your axes, you will have to reposition your text annotations.

---

## Creating Text Annotations in Plot Editing Mode

---

**Note** Add text annotations after you are finished moving or resizing your axes. Text annotations created in plot edit mode are not anchored to axes. If you move or resize an axes, you will have to move the text annotations as well.

---

To add a text annotation to a graph:

- 1 Click on the **Insert** menu and choose the **Text** option or click the text button in the figure window toolbar.

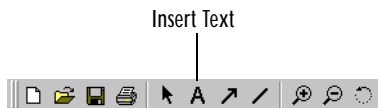

MATLAB changes the cursor to a text insertion cursor.

---

**Note** After you use insert text, plot edit mode is enabled in the figure, if it was not already enabled.

---

- 2 Position the cursor where you want to add a text annotation in the graph and click. MATLAB opens a text editing box at that point in the graph.
- 3 Enter text.
- 4 Click anywhere in the figure background to close the text entry box. If you click on another object in the figure, such as an axes or line, you close the text entry box but also automatically select the object you clicked on.

## Creating Text Annotations with the `text` or `gtext` Command

To create a text annotation using the `text` function, you must specify the text and its location in the graph, using x- and y-coordinates. You specify the coordinates in the units of the graph.

For example, the following code creates text annotations at specific points in the Lotka-Volterra Predator-Prey Population Model graph.

```
str1(1) = {'Many Predators;'};
str1(2) = {'Prey Population'};
str1(3) = {'Will Decline'};
text(7,220,str1)
```

```
str2(1) = {'Few Predators;'};
str2(2) = {'Prey Population'};
str2(3) = {'Will Increase'};
text(5.5,125,str2)
```

This example also illustrates how to create multi-line text annotations with cell arrays.

### Calculating the Position of Text Annotations

You can also calculate the positions of text annotations in a graph. The following code adds annotations at three data points on a graph.

```
text(3*pi/4,sin(3*pi/4),...
    '\leftarrow sin(t) = .707',...
    'FontSize',16)

text(pi,sin(pi),'\leftarrow sin(t) = 0',...
    'FontSize',16)

text(5*pi/4,sin(5*pi/4),'sin(t) = -.707\rightarrow',...
    'HorizontalAlignment','right',...
    'FontSize',16)
```

The `HorizontalAlignment` of the text string `'sin(t) = -.707 \rightarrow'` is set to `right` to place it on the left side of the point `[5*pi/4,sin(5*pi/4)]` on the graph. For more information about aligning text annotations, see “Text Alignment” on page 3-19.

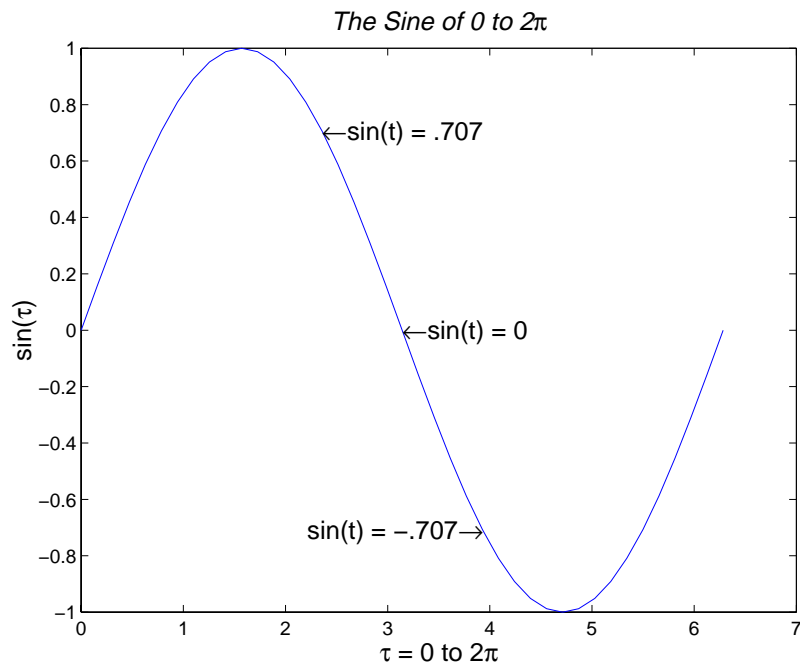

You can use text objects to annotate axes at arbitrary locations. MATLAB locates text in the data units of the axes. For example, suppose you plot the function  $y = Ae^{-\alpha t}$  with  $A = 0.25$ ,  $\alpha = 0.005$ , and  $t = 0$  to 900.

```
t = 0:900;  
plot(t,0.25*exp(-0.005*t))
```

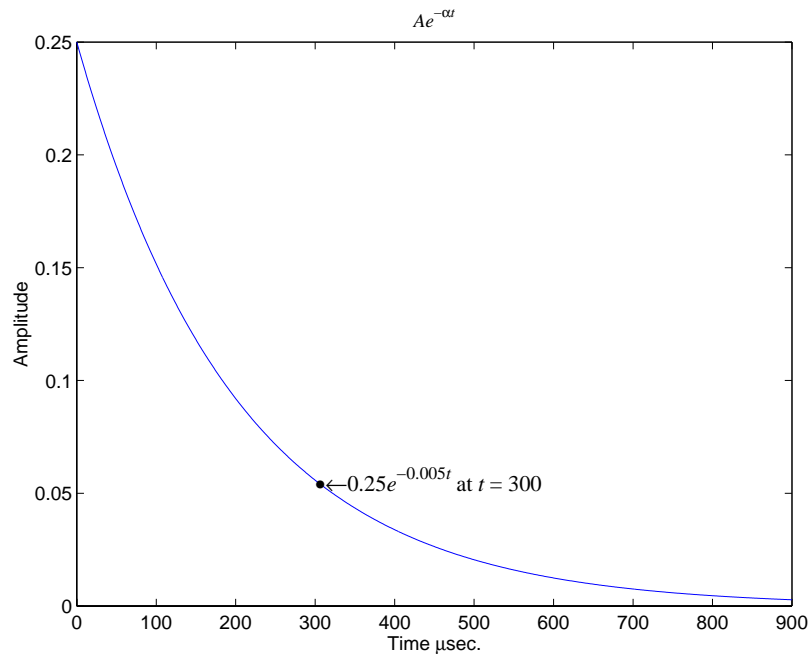

To annotate the point where the value of  $t = 300$ , calculate the text coordinates using the function you are plotting.

```
text(300, .25*exp(-0.005*300), ...
'\bullet\leftarrow\fontname{times}0.25{\ite}^{-0.005{\itt}} at {\itt} =
300', ...
'FontSize', 14)
```

This statement defines the text Position property as  $x = 300$ ,

$y = 0.25 e^{-0.005 \times 300}$ . The default text alignment places this point to the left of the string and centered vertically with the rectangle defined by the text Extent property. For information about changing this default text alignment, see the following section, “Text Alignment.”

### Text Alignment

The HorizontalAlignment and the VerticalAlignment properties control the placement of the text characters with respect to the specified  $x$ -,  $y$ -, and

*z*-coordinates. The following diagram illustrates the options for each property and the corresponding placement of the text.

Text `HorizontalAlignment` property viewed with the `VerticalAlignment` property set to `middle` (the default).

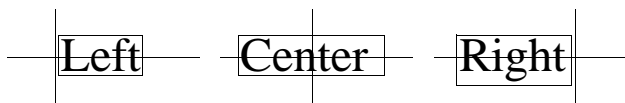

Text `VerticalAlignment` property viewed with the `HorizontalAlignment` property set to `left` (the default).

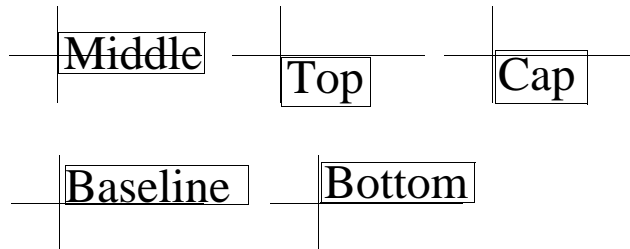

The default alignment is:

- `HorizontalAlignment = left`
- `VerticalAlignment = middle`

MATLAB does not place the text `String` exactly on the specified `Position`. For example, the previous section showed a plot with a point annotated with text. Zooming in on the plot enables you to see the actual positioning of the text.

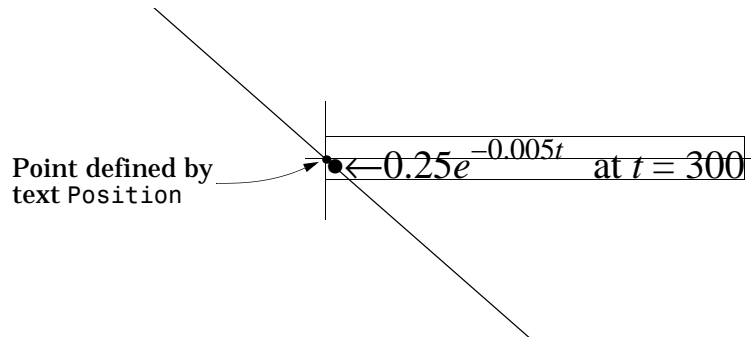

The small dot is the point specified by the text `Position` property. The larger dot is the bullet defined as the first character in the text `String` property.

### Example - Aligning Text

Suppose you want to label the minimum and maximum values in a plot with text that is anchored to these points and that displays the actual values. This example uses the plotted data to determine the location of the text and the values to display on the graph. One column from the peaks matrix generates the data to plot.

```
Z = peaks;
h = plot(Z(:,33));
```

The first step is to find the indices of the minimum and maximum values to determine the coordinates needed to position the text at these points (`get`, `find`). Then create the string by concatenating the values with a description of what the values are.

```
x = get(h,'XData'); % Get the plotted data
y = get(h,'YData');
imin = find(min(y) == y); % Find the index of the min and max
imax = find(max(y) == y);
text(x(imin),y(imin),[' Minimum = ',num2str(y(imin))],...
     'VerticalAlignment','middle',...
     'HorizontalAlignment','left',...
     'FontSize',14)
text(x(imax),y(imax),['Maximum = ',num2str(y(imax))],...
     'VerticalAlignment','bottom',...
     'HorizontalAlignment','right',...)
```

```
'FontSize',14)
```

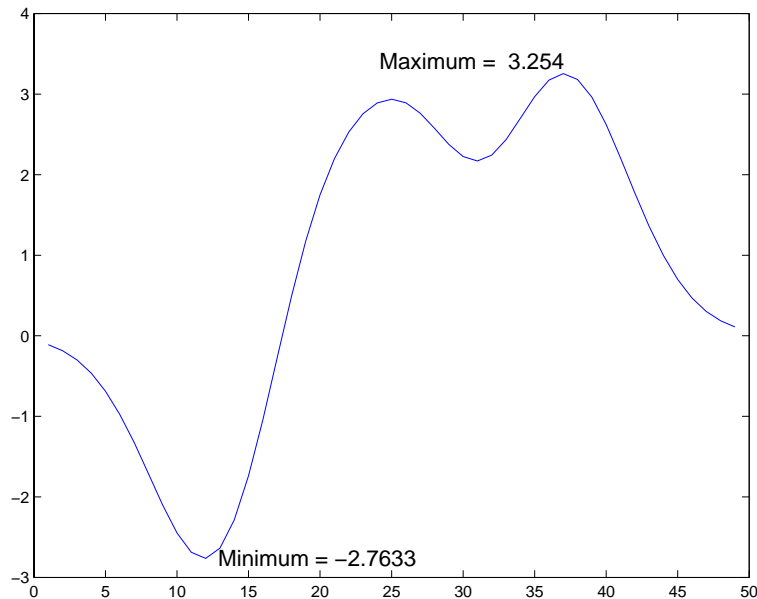

The text function positions the string relative to the point specified by the coordinates, in accordance with the settings of the alignment properties. For the minimum value, the string appears to the right of the text position point; for the maximum value the string appears above and to the left of the text position point. The text always remains in the plane of the computer screen, regardless of the view.

## Editing Text Annotations

You can edit any of the text labels or annotations in a graph:

- 1 Start plot edit mode.
- 2 Double-click on the string. Or right-click on the string and select **String** from the context-sensitive pop-up menu.

An editing box appears around the text.



- 3 Make any changes to the text.
- 4 Click anywhere outside of the text edit box to end text editing.

---

**Note** To create special characters in text, such as Greek letters or mathematical symbols, be sure to use TeX sequences – see the `text` command string property. If you create special characters by using the **Edit Font Properties** dialog box and selecting the Symbol font family, you will not be able to edit that text object using MATLAB commands.

---

## Including Symbols and Greek Letters in Text Strings

Text objects support a subset of TeX characters that enable you to use symbols in the title and axis labels. See the `text` String property for a list of available TeX characters.

For example,

```
title('{\itAe}^{\-\alpha\itt}sin\beta{\itt} \alpha<<\beta')
xlabel('Time \musec.')
ylabel('Amplitude')
```

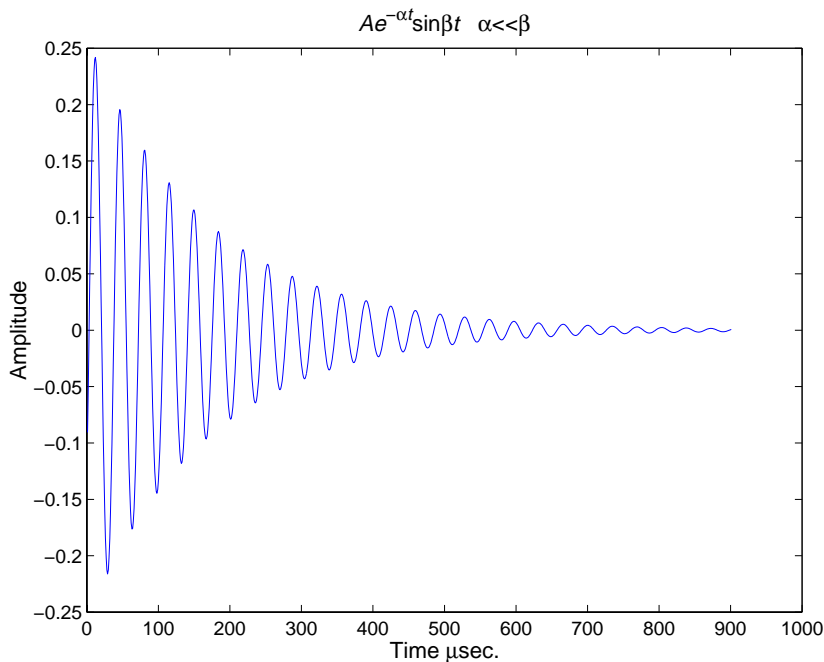

The backslash character “\” precedes all TeX character sequences. Looking at the string defining the title illustrates how to use these characters.

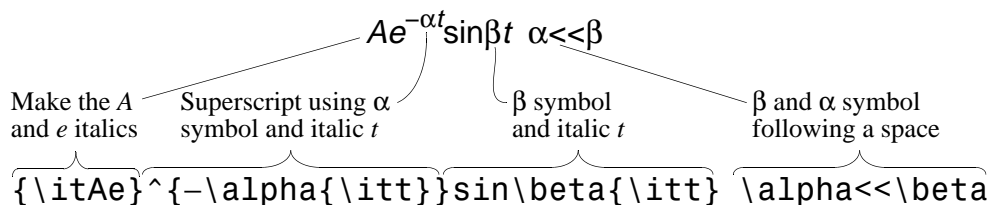

The text Interpreter property controls the interpretation of TeX characters. If you set this property to none, MATLAB interprets the special characters literally.

## Using Variables in Text Strings

Any string variable is a valid specification for the text String property. For example, each row of the matrix `PersonalData` contains specific information about a person (note that all but the longest row is padded with a space so that each has the same number of columns).

```
PersonalData = ['Jack Straw  '; '489 Main St.'; 'Wichita KN  '];
```

To display the data, index into the desired row.

```
text(x1,y1,['Name: ',PersonalData(1,:)])
text(x2,y2,['Address: ',PersonalData(2,:)])
text(x3,y3,['City and State: ',PersonalData(3,:)])
```

You can specify numeric variables in text strings using the `num2str` (number to string) function. For example, if you type on the command line,

```
x = 21;
['Today is the ',num2str(x),'st day.']
```

MATLAB concatenates the three separate strings into one.

```
Today is the 21st day.
```

Since the result is a valid string, you can specify it as a value for the text String property.

```
text(xcoord,ycoord,['Today is the ',num2str(x),'st day.'])
```

## Example - Multiline Text

MATLAB supports multiline text strings using cell arrays. Simply define a string variable as a cell array with one line per cell. This example defines two cell arrays, one used for a `uicontrol` and the other as text.

```
str1(1) = {'Center each line in the Uicontrol'};
str1(2) = {'Also check out the textwrap function'};

str2(1) = {'Each cell is a quoted string'};
str2(2) = {'You can specify how the string is aligned'};
str2(3) = {'You can use LaTeX symbols like \pi \chi \xi'};
str2(4) = {'\bfOr use bold \rm\itor italic font\rm'};
str2(5) = {'\fontname{courier}Or even change fonts'};
plot(0:6,sin(0:6))
```

```
uicontrol('Style','text','Position',[80 80 250 65],...  
         'String',str1);  
text(5.75,sin(2.5),str2,'HorizontalAlignment','right')
```

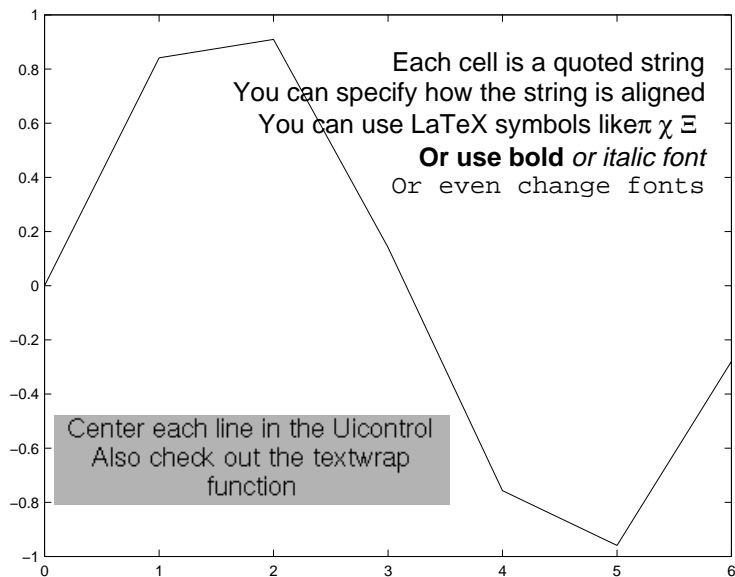

## Adding Arrows and Lines to a Graph

With plot editing mode enabled, you can add arrows and lines anywhere in a figure window.

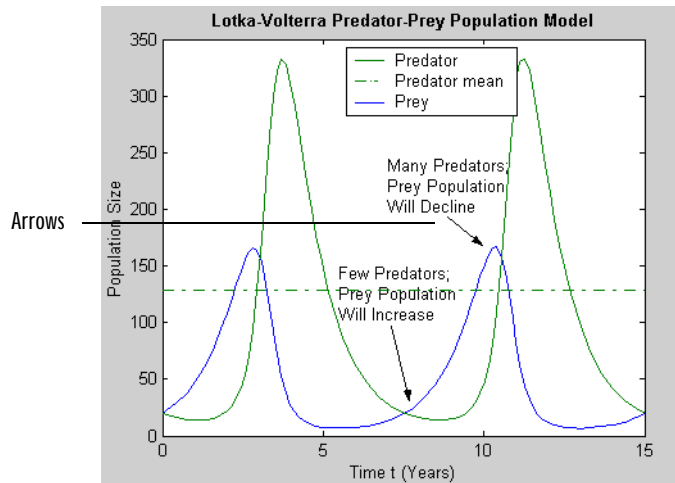

You can also use arrow characters (TeX characters) to create arrows using the text command. However, arrows created this way can only point to the left or right, horizontally. See “Calculating the Position of Text Annotations” on page 3-17 for an example.

## Creating Arrows and Lines in Plot Editing Mode

**Note** Add arrow and line annotations after you are finished moving or resizing your axes. Arrows and lines annotations are not anchored to the axes. If you move or resize the axes, you will have to reposition your arrow and line annotations as well.

To add an arrow or line annotation to a graph:

- 1 Click on the **Insert** menu and choose the **Arrow** or **Line** option, or click the Arrow or Line buttons in the figure window toolbar.



MATLAB changes the cursor to a cross-hair style.

- 2 Position the cursor in the figure where you want to start the line or arrow and press either mouse button. Hold the button down and move the mouse to define the length and direction of the line or arrow.
- 3 Release the mouse button.

---

**Note** After you add an arrow or line, plot edit mode is enabled in the figure, if it was not already enabled.

---

## Editing Arrows and Line Annotations

You can edit the appearance of arrow and line annotations using the Property Editor.

With plot editing mode enabled, double-click on the arrow or line annotation to start the Property Editor, if it is not already started. The Property Editor displays the set of panels specific to arrow or line objects. Use the fields in the panels to change the style, width, color, and many other characteristics of the arrow or line annotation object.

## Adding Plots of Basic Statistics to a Graph

The MATLAB Data Statistics tool:

- Calculates basic statistics about the central tendency and variability of data plotted in a graph.
- Plots these statistics in the graph

For example, the following figure includes a plot of the mean of the Predator  $y$ -data.

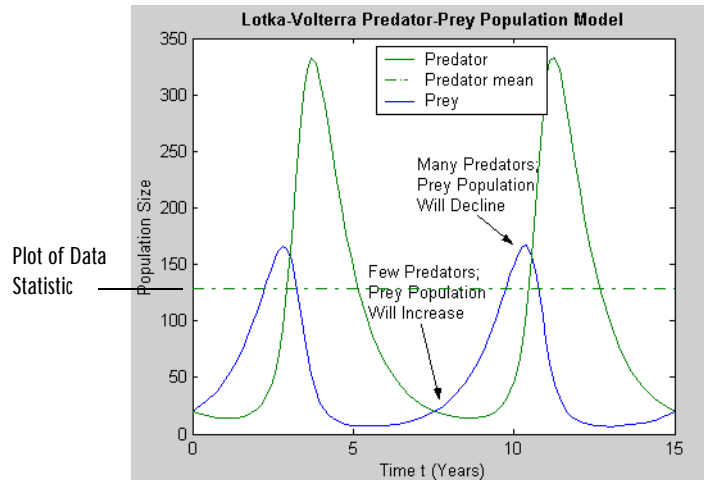

The following sections provide more information about using the Data Statistics tool:

- “Example - Plotting the Mean of a Data Set” on page 3-30
- “Formatting Plots of Data Statistics” on page 3-32
- “Statistics Plotted by the Data Statistics Tool” on page 3-32
- “Viewing Statistics for Multiple Plots” on page 3-33
- “Saving Statistics to the MATLAB Workspace” on page 3-34

## Example - Plotting the Mean of a Data Set

To add a plot of the mean of a data set to a graph:

- 1 Plot your data. For example, use these commands to plot historical population data from the United States census.

```
load census  
plot(cdate,pop, '+' )
```

- 2 Select the **Data Statistics** option from the figure window **Tools** menu.

The Data Statistics tool calculates basic statistics on the *x*-data and *y*-data of the plot in the graph and displays the results in a dialog box.

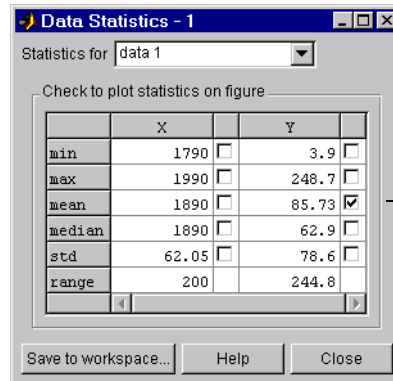

Select the statistic you want to plot by clicking in its check box.

- 3 Select the statistic you want to plot in your graph by clicking in the check box next to the value.

For example, to add a plot of the mean of the population data (*y*-data) to the graph, click in the check box next to the value (as shown in the figure). The Data Statistics tool adds the plot of the mean to the graph.



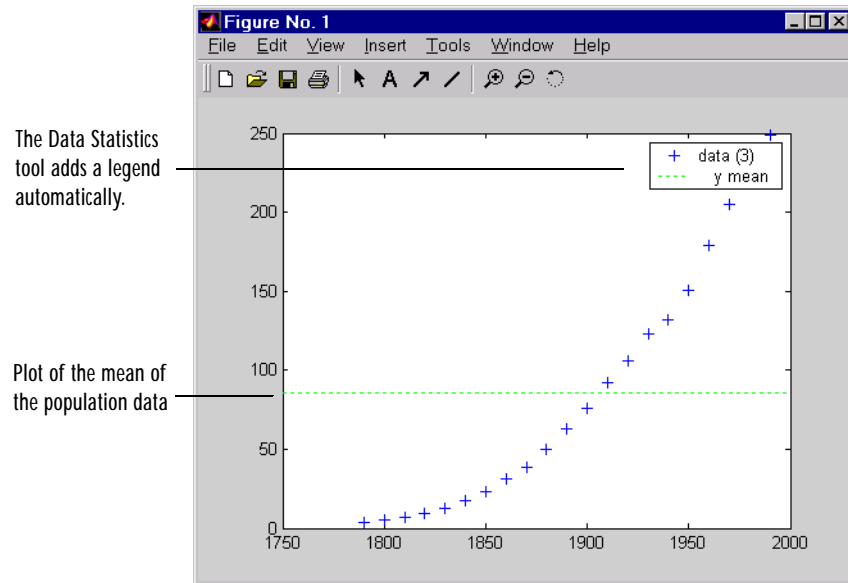

### Using a Legend with Data Statistics

When you activate the Data Statistics tool, it calculates statistics for the plotted data and automatically adds a legend to the graph, if the graph doesn't already have one.

Initially, the legend only includes entries for the data sets plotted in the graph. In the legend, each data set is identified by its tag. (A tag is a user-defined text string that can be associated with any graphics object. For information about creating tags, see "Identifying Objects in a Graph" on page 1-20.) If there are data sets in the graph that do not have tags, the Data Statistics tool creates a label for them, using `data 1` to identify the first plot, `data 2` to identify the second plot, and so on.

When you add a plot of one or more statistics to the graph, the Data Statistics tool adds an entry in the legend for the new plot. The Data Statistics tool assigns the plotted statistic a descriptive name that identifies it in the legend. In the example, the plotted statistic has the name `y mean` in the legend.

### Formatting Plots of Data Statistics

The Data Statistics tool uses color and line style to distinguish the plots of statistics from the other plots in a graph. However, like any other plot in a graph, you can change these characteristics.

---

**Note** Do not edit the format of the plots of data statistics, until you are finished adding them to a graph. If you edit a plot of data statistics, delete the plot, and then add it back, any formatting you did to the plotted statistics will be lost.

---

To modify the properties of a plotted statistic:

- 1 Enable plot editing mode in the figure window.
- 2 Double-click on the plot of the statistic. This starts the MATLAB Property Editor, which provides access to properties of the line object used to plot the statistic.

You can also access a subset of these properties by right-clicking on the plot. This brings up the plot's context menu, which includes options for specifying line width, line style, and color.

- 3 Change the properties of the plot and click **Apply**.

### Statistics Plotted by the Data Statistics Tool

---

**Note** You can only use the Data Statistics tool to generate statistics for two-dimensional data (vectors and matrices).

---

The following table lists the statistics calculated by the Data Statistics tool. The table includes the name of the MATLAB function used to calculate the

statistic. For more information about these statistical functions, see the “Basic Data Analysis Functions” in the “Data Analysis and Statistics” chapter.

Statistic	Description	MATLAB Function
Maximum	The largest value in the data set	max
Minimum	The smallest value in the data set	min
Mean	The average of all the values in the data set	mean
Median	The middle value in the data set	median
Range	The interval between the lowest value and the highest value in the data set. The Data Statistic tool does not plot the range statistic.	n/a
Standard deviation	A measure characterizing the amount of variation among the values in the data set  <b>Note:</b> The Data Statistics tool uses two lines to plot the standard deviation in a graph. The lines represent the boundaries of one standard deviation on either side of the mean of the data set.	std

### Automatic Updating of Statistics

If you have the Data Statistics tool displayed and you change the  $x$ -data or  $y$ -data of a plot, the Data Statistics tool automatically regenerates the statistics for that plot.

### Viewing Statistics for Multiple Plots

The Data Statistics tool calculates basic statistics for every 2-D plot in a graph, but displays the statistics for only one plot at time.

To view the statistics for a particular plot in a graph:

- 1 Click the **Statistics for** menu in the Data Statistics dialog box.

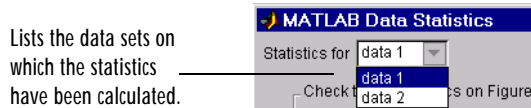

This menu lists all the data sets plotted in the graph, identifying each data set by its tag. (A tag is a user-defined text string that can be associated with any graphics object.) For plots in the graph that do not have tags, the Data Statistics tool uses data1 to identify the first plot, data2 to identify the second plot, and so on.

- 2 Select a plot from the list. The Data Statistics tool updates the values displayed in the dialog box.

## Saving Statistics to the MATLAB Workspace

To save the statistics generated by the Data Statistics tool to the MATLAB workspace, follow this procedure:

---

**Note** You must repeat this procedure for each plot in a graph containing multiple plots.

---

- 1 Click the **Save to Workspace** button.
- 2 In the **Save Statistics to Workspace** dialog box, specify which sets of statistics you want to save, *x*-data or *y*-data, and specify the names you want to assign to the variables in which the statistics will be stored.

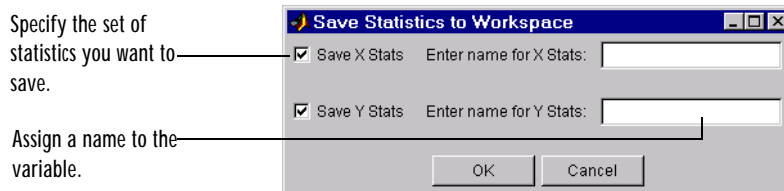

The Data Statistics tool saves each set of statistics in a structure. For example, if you save the set of statistics on the x-data in the census in the variable `census_dates`, the contents of the structure looks like this.

```
census_dates =  
  
    min: 1790  
    max: 1990  
    mean: 1890  
median: 1890  
    std: 62.0484  
    range: 200
```



# Creating Specialized Plots

---

<b>Introduction</b> . . . . .	4-2
<b>Bar and Area Graphs</b> . . . . .	4-3
<b>Pie Charts</b> . . . . .	4-15
<b>Histograms</b> . . . . .	4-18
<b>Discrete Data Graphs</b> . . . . .	4-23
<b>Direction and Velocity Vector Graphs</b> . . . . .	4-32
<b>Contour Plots</b> . . . . .	4-38
<b>Interactive Plotting</b> . . . . .	4-49
<b>Animation</b> . . . . .	4-51

### Introduction

MATLAB supports a variety of graph types that enable you to present information effectively. The type of graph you select depends, to a large extent, on the nature of your data. The following list can help you select the appropriate graph:

- Bar and area graphs are useful to view results over time, comparing results, and displaying individual contribution to a total amount.
- Pie charts show individual contribution to a total amount.
- Histograms show the distribution of data values.
- Stem and stairstep plots display discrete data.
- Compass, feather, and quiver plots display direction and velocity vectors.
- Contour plots show equivalued regions in data.
- Interactive plotting enable you to select data points to plot with the pointer.
- Animations add an addition data dimension by sequencing plots.



## Bar and Area Graphs

Bar and area graphs display vector or matrix data. These types of graphs are useful for viewing results over a period of time, comparing results from different datasets, and showing how individual elements contribute to an aggregate amount. Bar graphs are suitable for displaying discrete data, whereas area graphs are more suitable for displaying continuous data.

Function	Description
bar	Displays columns of $m$ -by- $n$ matrix as $m$ groups of $n$ vertical bars
barh	Displays columns of $m$ -by- $n$ matrix as $m$ groups of $n$ horizontal bars
bar3	Displays columns of $m$ -by- $n$ matrix as $m$ groups of $n$ vertical 3-D bars
bar3h	Displays columns of $m$ -by- $n$ matrix as $m$ groups of $n$ horizontal 3-D bars
area	Displays vector data as stacked area plots

### Types of Bar Graphs

MATLAB has four specialized functions that display bar graphs. These functions display 2- and 3-D bar graphs, and vertical and horizontal bar graphs.

	Two-Dimensional	Three-Dimensional
Vertical	bar	bar3
Horizontal	barh	bar3h

### Grouped Bar Graph

By default, a bar graph represents each element in a matrix as one bar. Bars in a 2-D bar graph, created by the bar function, are distributed along the  $x$ -axis with each element in a column drawn at a different location. All elements in a row are clustered around the same location on the  $x$ -axis.

For example, define  $Y$  as a simple matrix and issue the `bar` statement in its simplest form.

```
Y = [5 2 1
      8 7 3
      9 8 6
      5 5 5
      4 3 2];
```

```
bar(Y)
```

The bars are clustered together by rows and evenly distributed along the  $x$ -axis.

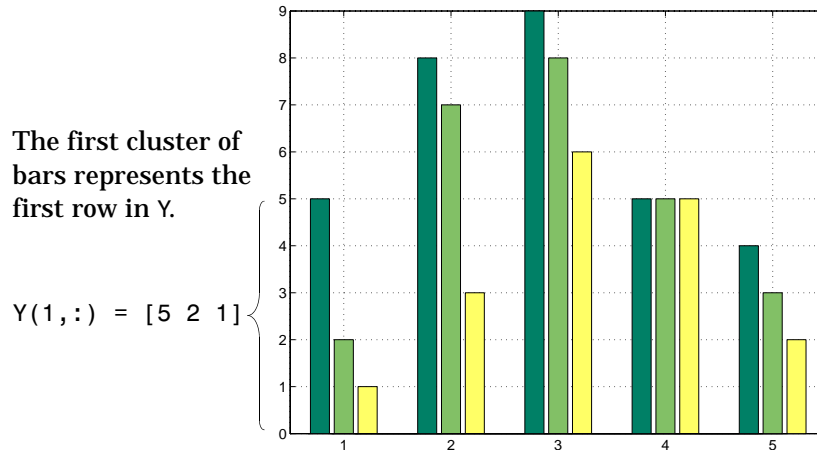

### Detached 3-D Bars

The `bar3` function, in its simplest form, draws each element as a separate 3-D block, with the elements of each column distributed along the  $y$ -axis. Bars that represent elements in the first column of the matrix are centered at 1 along the  $x$ -axis. Bars that represent elements in the last column of the matrix are centered at `size(Y,2)` along the  $x$ -axis. For example,

```
bar3(Y)
```

displays five groups of three bars along the  $y$ -axis. Notice that larger bars obscure  $Y(1,2)$  and  $Y(1,3)$ .

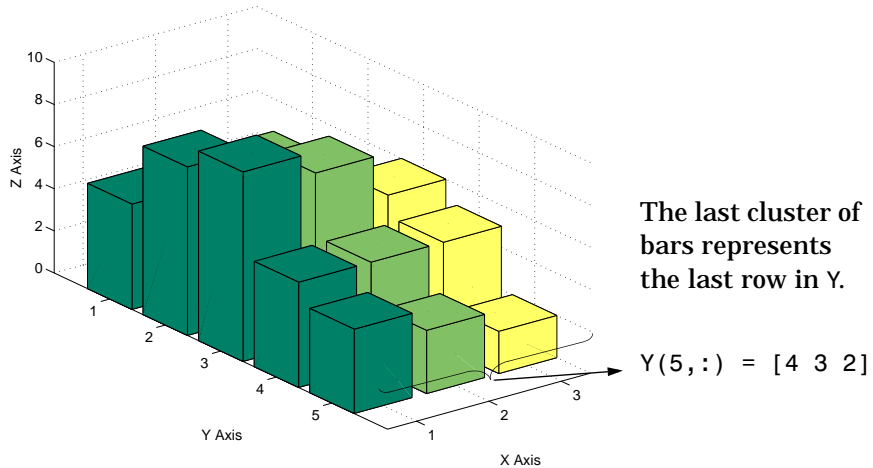

By default, `bar3` draws detached bars. The statement `bar3(Y, 'detach')` has the same effect.

**Labeling the Graph.** To add axes labels and  $x$  tick marks to this bar graph, use the statements

```
xlabel('X Axis')
ylabel('Y Axis')
zlabel('Z Axis')
set(gca, 'XTick', [1 2 3])
```

### Grouped 3-D Bars

Cluster the bars from each row beside each other by specifying the argument 'group'. For example,

```
bar3(Y, 'group')
```

groups the bars according to row and distributes the clusters evenly along the  $y$ -axis.

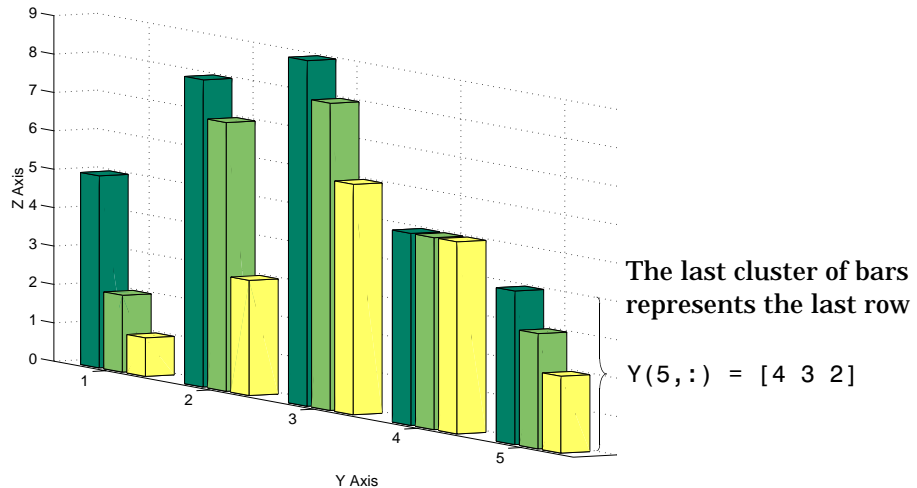

### Stacked Bar Graphs to Show Contributing Amounts

Bar graphs can show how elements in the same row of a matrix contribute to the sum of all elements in the row. These types of bar graphs are referred to as stacked bar graphs.

Stacked bar graphs display one bar per row of a matrix. The bars are divided into  $n$  segments, where  $n$  is the number of columns in the matrix. For vertical bar graphs, the height of each bar equals the sum of the elements in the row. Each segment is equal to the value of its respective element.

#### Redefining Y

```
Y = [5 1 2
     8 3 7
     9 6 8
     5 5 5
     4 2 3];
```

Create stacked bar graphs using the optional 'stack' argument. For example,

```
bar(Y,'stack')
grid on
set(gca,'Layer','top') % display gridlines on top of graph
```

creates a 2-D stacked bar graph, where all elements in a row correspond to the same  $x$  location.

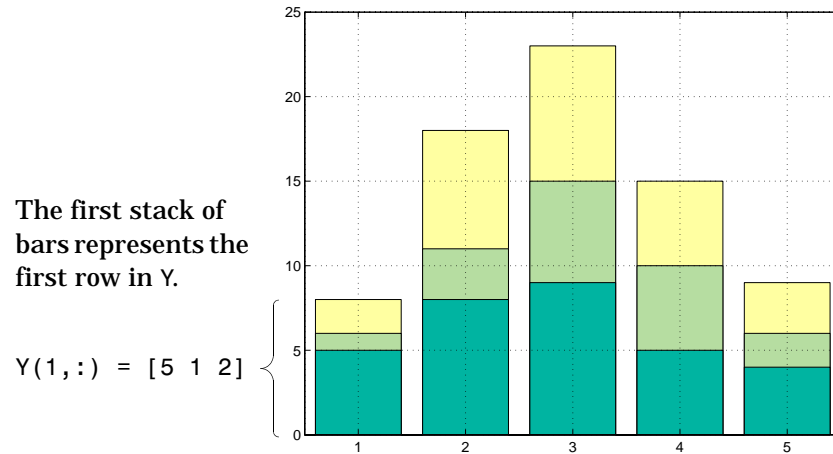

### Horizontal Bar Graphs

For horizontal bar graphs, the length of each bar equals the sum of the elements in the row. The length of each segment is equal to the value of its respective element.

```
barh(Y,'stack')
grid on
set(gca,'Layer','top') % Display gridlines on top of graph
```

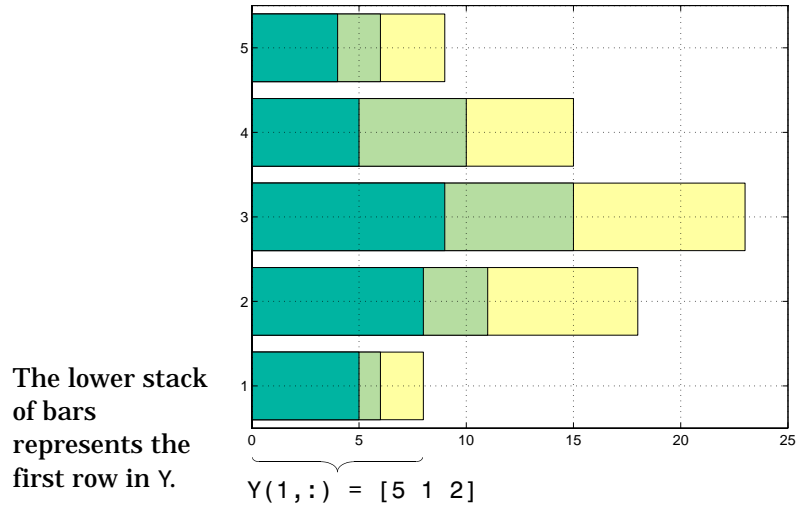

### Specifying X-Axis Data

Bar graphs automatically generate  $x$ -axis values and label the  $x$ -axis tick lines. You can specify a vector of  $x$  values (or  $y$  values in the case of horizontal bar graphs) to label the axes.

For example, given temperature data,

```
temp = [29 23 27 25 20 23 23 27];
```

obtained from samples taken every five days during a thirty-five day period,

```
days = 0:5:35;
```

you can display a bar graph showing temperature measured along the  $y$ -axis and days along the  $x$ -axis using

```
bar(days,temp)
```

These statements add labels to the  $x$ - and  $y$ -axis.

```
xlabel('Day')
ylabel('Temperature (^{0}C)')
```

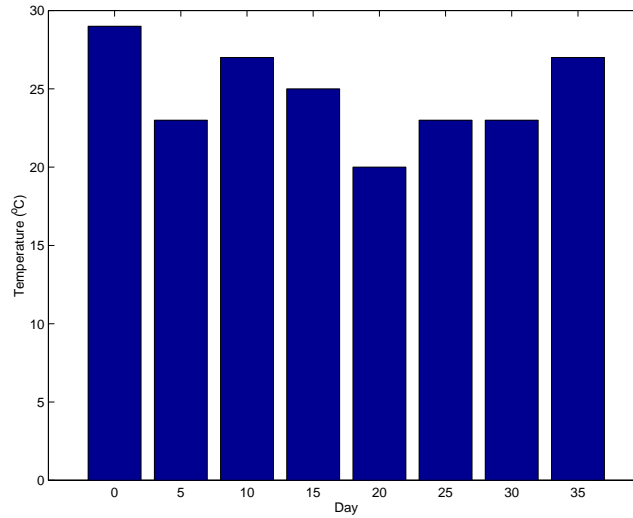

### Setting Y-Axis Limits

By default, the  $y$ -axis range is from 0 to 30. To focus on the temperature range from 15 to 30, change the  $y$ -axis limits.

```
set(gca, 'YLim', [15 30], 'Layer', 'top')
```

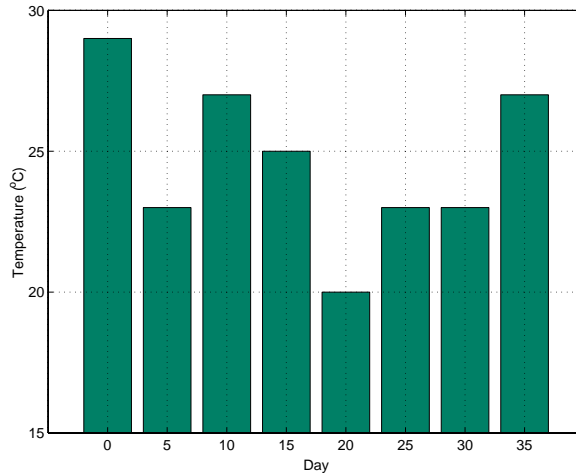

### Overlaying Plots on Bar Graphs

You can overlay data on a bar graph by creating another axes in the same position. This enables you to have an independent  $y$ -axis for the overlaid dataset (in contrast to the `hold on` statement, which uses the same axes).

For example, consider a bioremediation experiment that breaks down hazardous waste components into nontoxic materials. The trichloroethylene (TCE) concentration and temperature data from this experiment are

```
TCE = [515 420 370 250 135 120 60 20];  
temp = [29 23 27 25 20 23 23 27];
```

This data was obtained from samples taken every five days during a thirty-five day period.

```
days = 0:5:35;
```

Display a bar graph and label the  $x$ - and  $y$ -axis using the statements

```
bar(days,temp)  
xlabel('Day')  
ylabel('Temperature (^{o}C)')
```



## Overlaying a Line Plot on the Bar Graph

To overlay the concentration data on the bar graph, position a second axes at the same location as the first axes, but first save the handle of the first axes.

```
h1 = gca;
```

Create the second axes at the same location before plotting the second dataset.

```
h2 = axes('Position',get(h1,'Position'));
plot(days,TCE,'LineWidth',3)
```

To ensure that the second axes does not interfere with the first, locate the *y*-axis on the right side of the axes, make the background transparent, and set the second axes' *x*-tick marks to the empty matrix.

```
set(h2,'YAxisLocation','right','Color','none','XTickLabel',[])
```

Align the *x*-axis of both axes and display the grid lines on top of the bars.

```
set(h2,'XLim',get(h1,'XLim'),'Layer','top')
```

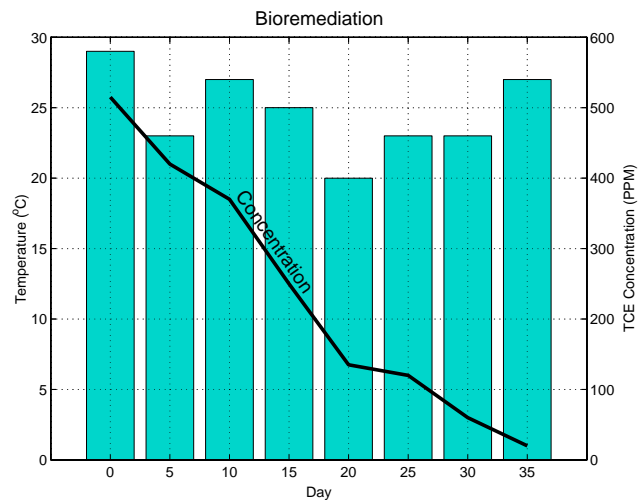

Annotating the Graph. These statements annotate the graph.

```
text(11,380,'Concentration','Rotation',-55,'FontSize',16)
```

```
ylabel('TCE Concentration (PPM)')
title('Bioremediation','FontSize',16)
```

To print the graph, set the current figure's `PaperPositionMode` to `auto`, which ensures the printed output matches the display.

```
set(gcf,'PaperPositionMode','auto')
```

### Area Graphs

The `area` function displays curves generated from a vector or from separate columns in a matrix. `area` plots the values in each column of a matrix as a separate curve and fills the area between the curve and the  $x$ -axis.

#### Area Graphs Showing Contributing Amounts

Area graphs are useful for showing how elements in a vector or matrix contribute to the sum of all elements at a particular  $x$  location. By default, `area` accumulates all values from each row in a matrix and creates a curve from those values.

Using this matrix,

```
Y = [5 1 2
      8 3 7
      9 6 8
      5 5 5
      4 2 3];
```

the statement,

```
area(Y)
```

displays a graph containing three area graphs, one per column.

The height of the area graph is the sum of the elements in each row. Each successive curve uses the preceding curve as its base.

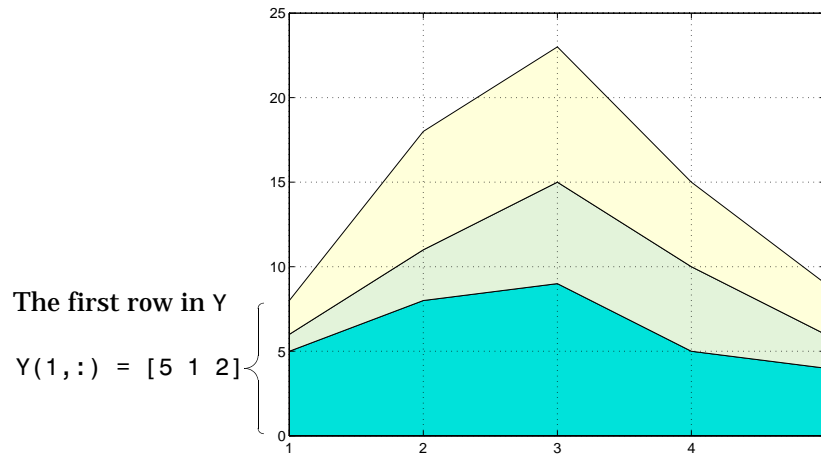

**Displaying the Grid on Top.** To display the grid lines in the foreground of the area graph and display only five grid lines along the  $x$ -axis, use the statements

```
set(gca, 'Layer', 'top')
set(gca, 'XTick', 1:5)
```

## Comparing Datasets with Area Graphs

Area graphs are useful for comparing different datasets. For example, given a vector containing sales figures,

```
sales = [51.6 82.4 90.8 59.1 47.0];
```

for the five-year period

```
x = 90:94;
```

and a vector containing profits figures for the same five-year period

```
profits = [19.3 34.2 61.4 50.5 29.4];
```

display both as two separate area graphs within the same axes. Set the color of the area interior (`FaceColor`), its edges (`EdgeColor`), and the width of the edge lines (`LineWidth`). See `patch` for a complete list of properties.

```
area(x, sales, 'FaceColor', [.5 .9 .6], ...
```

```
        'EdgeColor','b',...
        'LineWidth',2)
hold on
area(x,profits,'FaceColor',[.9 .85 .7],...
     'EdgeColor','y',...
     'LineWidth',2)
hold off
```

To annotate the graph, use the statements

```
set(gca,'XTick',[90:94])
set(gca,'Layer','top')
gtext('\leftarrow Sales')
gtext('Profits')
gtext('Expenses')
xlabel('Years','FontSize',14)
ylabel('Expenses + Profits = Sales in 1,000's','FontSize',14)
```

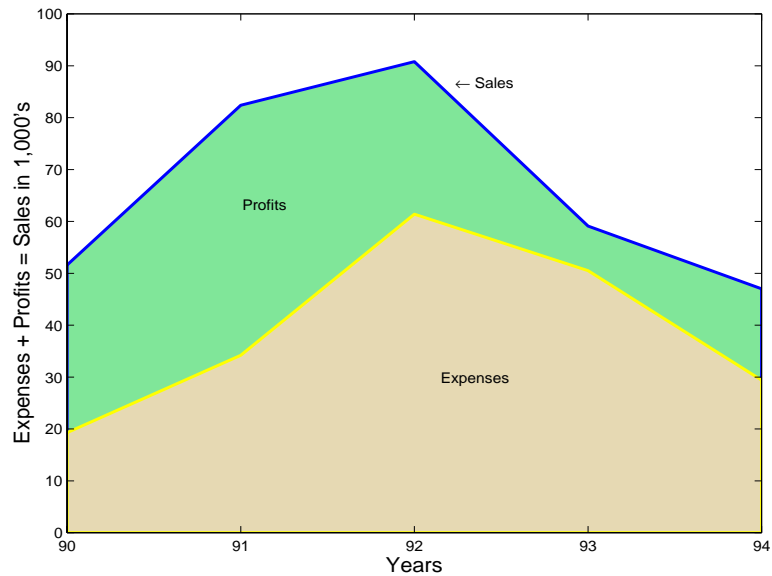

## Pie Charts

Pie charts display the percentage that each element in a vector or matrix contributes to the sum of all elements. `pie` and `pie3` create 2-D and 3-D pie charts.

### Example – Pie Chart

Here is an example using the `pie` function to visualize the contribution that three products make to total sales. Given a matrix `X` where each column of `X` contains yearly sales figures for a specific product over a five-year period,

```
X = [19.3 22.1 51.6;  
     34.2 70.3 82.4;  
     61.4 82.9 90.8;  
     50.5 54.9 59.1;  
     29.4 36.3 47.0];
```

sum each row in `X` to calculate total sales for each product over the five-year period.

```
x = sum(X);
```

You can offset the slice of the pie that makes the greatest contribution using the `explode` input argument. This argument is a vector of zero and nonzero values. Nonzero values offset the respective slice from the chart.

First, create a vector containing zeros.

```
explode = zeros(size(x));
```

Then find the slice that contributes the most and set the corresponding `explode` element to 1.

```
[c,offset] = max(x);  
explode(offset) = 1;
```

The `explode` vector contains the elements `[0 0 1]`. To create the exploded pie chart, use the statement.

```
h = pie(x,explode); colormap summer
```

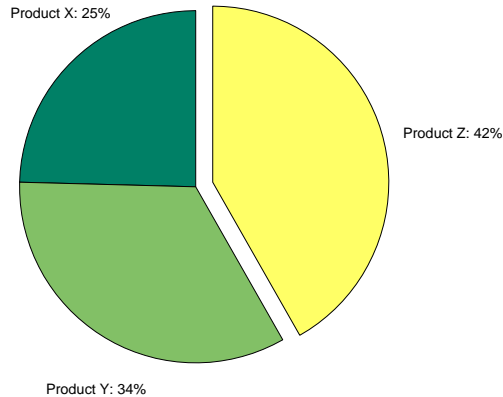

### Labeling the Graph

The pie chart's labels are text graphics objects. To modify the text strings and their positions, first get the objects' strings and extents. Braces around a property name ensure that get outputs a cell array, which is important when working with multiple objects.

```
textObjs = findobj(h,'Type','text');
oldStr = get(textObjs,{'String'});
val = get(textObjs,{'Extent'});
oldExt = cat(1,val{:});
```

Create the new strings, then set the text objects' String properties to the new strings.

```
Names = {'Product X: '; 'Product Y: '; 'Product Z: '};
newStr = strcat(Names,oldStr);
set(textObjs,{'String'},newStr)
```

Find the difference between the widths of the new and old text strings and change the values of the Position properties.

```
val1 = get(textObjs, {'Extent'});
newExt = cat(1, val1{:});
offset = sign(oldExt(:,1)).*(newExt(:,3)-oldExt(:,3))/2;
```

```
pos = get(textObjs, {'Position'});  
textPos = cat(1, pos{:});  
textPos(:,1) = textPos(:,1)+offset;  
set(textObjs,{'Position'},num2cell(textPos,[3,2]))
```

## Removing a Piece from a Pie Charts

When the sum of the elements in the first input argument is equal to or greater than 1, `pie` and `pie3` normalize the values. So, given a vector of elements  $x$ , each slice has an area of  $x_i/\text{sum}(x_i)$ , where  $x_i$  is an element of  $x$ . The normalized value specifies the fractional part of each pie slice.

When the sum of the elements in the first input argument is less than 1, `pie` and `pie3` do not normalize the elements of vector  $x$ . They draw a partial pie. For example,

```
x = [.19 .22 .41];  
pie(x)
```

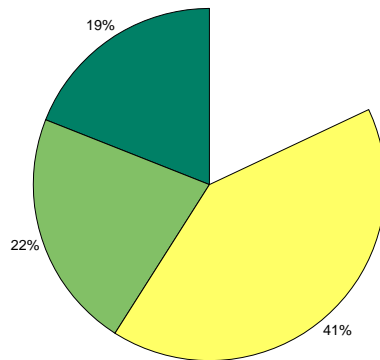

## Histograms

MATLAB's histogram functions show the distribution of data values. The functions that create histograms are `hist` and `rose`.

Function	Description
<code>hist</code>	Displays data in a Cartesian coordinate system
<code>rose</code>	Displays data in a polar coordinate system

The histogram functions count the number of elements within a range and display each range as a rectangular bin. The height (or length when using `rose`) of the bins represents the number of values that fall within each range.

### Histograms in Cartesian Coordinate Systems

The `hist` function shows the distribution of the elements in `Y` as a histogram with equally spaced bins between the minimum and maximum values in `Y`. If `Y` is a vector and is the only argument, `hist` creates up to 10 bins. For example,

```
yn = randn(10000,1);  
hist(yn)
```

generates 10,000 random numbers and creates a histogram with 10 bins distributed along the *x*-axis between the minimum and maximum values of `yn`.



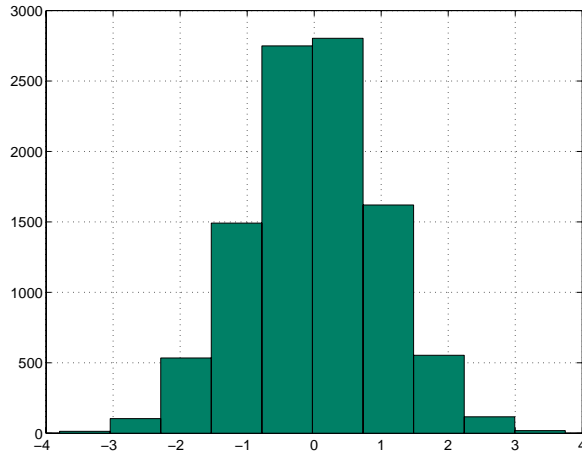

### Matrix Input Argument

When  $Y$  is a matrix, `hist` creates a set of bins for each column, displaying each set in a separate color. The statements

```
Y = randn(10000,3);  
hist(Y)
```

create a histogram showing 10 bins for each column in  $Y$ .

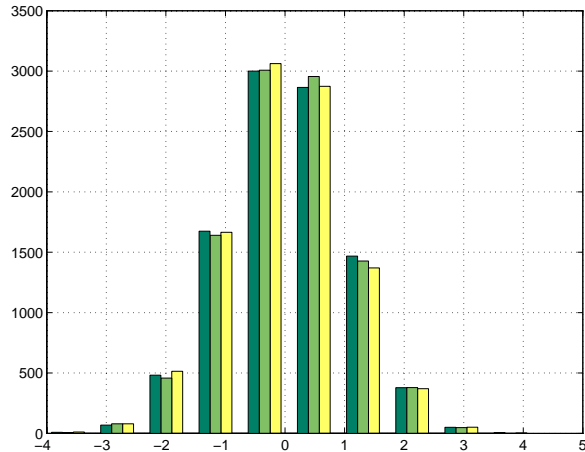

### Histograms in Polar Coordinate Systems

A rose plot is a histogram created in a polar coordinate system. For example, consider samples of the wind direction taken over a 12-hour period.

```
wdir = [45 90 90 45 360 335 360 270 335 270 335 335];
```

To display this data using the rose function, convert the data to radians; then use the data as an argument to the rose function. Increase the `LineWidth` property of the line to improve the visibility of the plot (`findobj`).

```
wdir = wdir * pi/180;
rose(wdir)
hline = findobj(gca,'Type','line');
set(hline,'LineWidth',1.5)
```

The plot shows that the wind direction was primarily  $335^\circ$  during the 12-hour period.

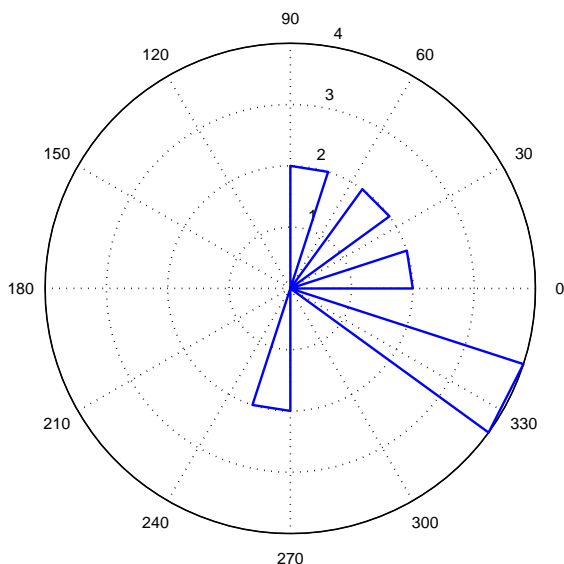

## Specifying Number of Bins

`hist` and `rose` interpret their second argument in one of two ways — as the locations on the axis or the number of bins. When the second argument is a vector `x`, it specifies the locations on the axis and distributes the elements in `length(x)` bins. When the second argument is a scalar `x`, `hist` and `rose` distribute the elements in `x` bins.

For example, compare the distribution of data created by two MATLAB functions that generate random numbers. The `randn` function generates normally distributed random numbers, whereas the `rand` function generates uniformly distributed random numbers.

```
yn = randn(10000,1);
yu = rand(10000,1);
```

The first histogram displays the data distribution resulting from the `randn` function. The locations on the  $x$ -axis and number of bins depend on the vector `x`.

```
x = min(yn):.2:max(yn);
subplot(1,2,1)
```

```
hist(yn,x)
title('Normally Distributed Random Numbers','FontSize',16)
```

The second histogram displays the data distribution resulting from the `rand` function and explicitly creates 25 bins along the  $x$ -axis.

```
subplot(1,2,2)
hist(yu,25)
title('Uniformly Distributed Random Numbers','FontSize',16)
```

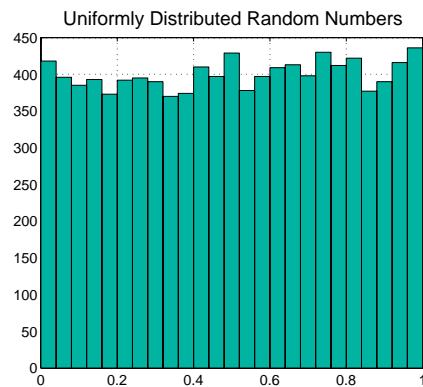
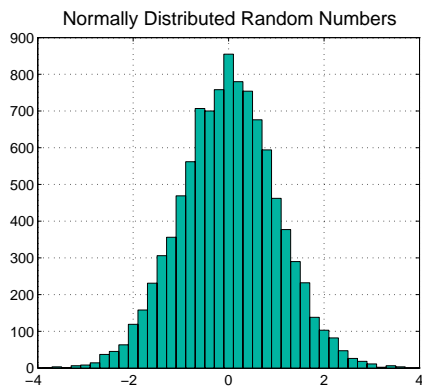

---

**Note** You can change the aspect ratio of the histogram plots using the mouse to resize the figure window. However, before creating hardcopy output, set the figure's `PaperPositionMode` to `auto` to produce printed output that matches the display.

```
set(gcf,'PaperPositionMode','auto')
```

---

## Discrete Data Graphs

MATLAB has a number of specialized functions that are appropriate for displaying discrete data. This section describes how to use stem plots and stairstep plots to display this type of data. (Bar charts, discussed earlier in this section, are also suitable for displaying discrete data.)

### Discrete Data Plotting Commands

Function	Description
stem	Displays a discrete sequence of $y$ -data as stems from $x$ -axis
stem3	Displays a discrete sequence of $z$ -data as stems from $xy$ -plane
stairs	Displays a discrete sequence of $y$ -data as steps from $x$ -axis

### Two-Dimensional Stem Plots

A stem plot displays data as lines (stems) terminated with a marker symbol at each data value. In a 2-D graph, stems extend from the  $x$ -axis.

The stem function displays two-dimensional discrete sequence data. For example, evaluating the function  $y = e^{-\alpha t} \cos \beta t$  with the values,

```
alpha = .02; beta = .5; t = 0:4:200;
y = exp(-alpha*t).*sin(beta*t);
```

yields a vector of discrete values for  $y$  at given values of  $t$ . A line plot shows the data points connected with a straight line.

```
plot(t,y)
```

## 4 Creating Specialized Plots

---

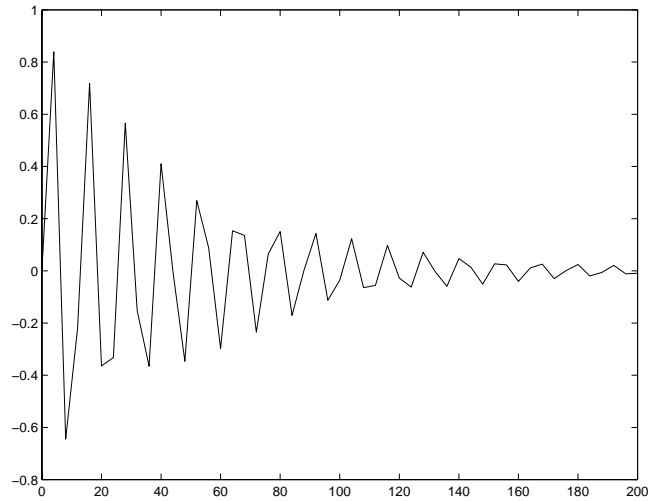

A stem plot of the same function plots only discrete points on the curve.

```
stem(t,y)
```

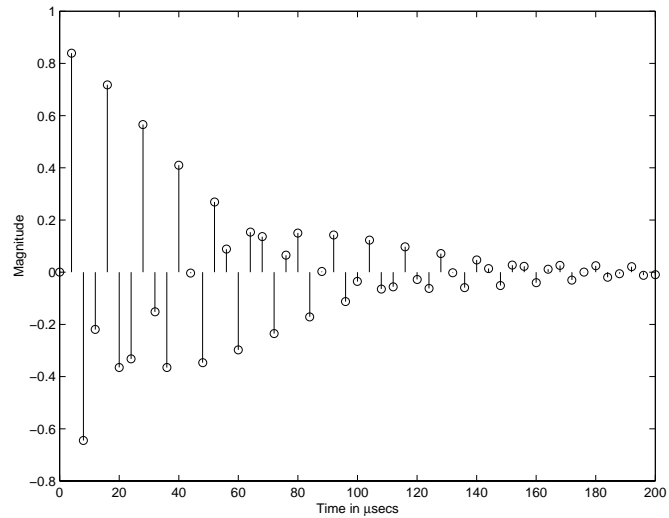

Add axes labels to the  $x$ - and  $y$ -axis.

```
xlabel('Time in \musecs')
ylabel('Magnitude')
```

If you specify only one argument, the number of samples is equal to the length of that argument. In this example, the number of samples is a function of  $t$ , which contains 51 elements and determines the length of  $y$ .

### Customizing the Graph

You can specify the line style, the type of marker, and the color used in the stem plot. For example, adding the string `':sr'` specifies a dotted line (`:`), a square marker (`s`), and a red color (`r`). The `'fill'` argument colors the face of the marker.

```
stem(t,y,'—sr','fill')
```

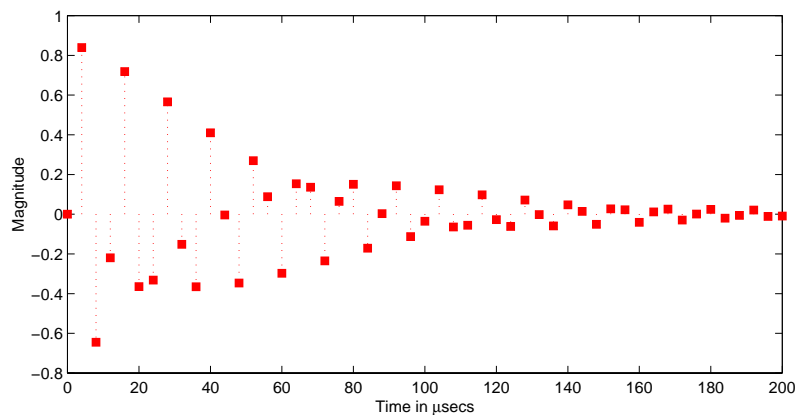

Setting the aspect ratio of the  $x$ - and  $y$ -axis to 2:1 improves the utility of the graph. You can do this by setting the aspect ratio of the plot box using `pbaspect`.

```
pbaspect([2,1,1])
```

This is equivalent to setting the `PlotBoxAspectRatio` property directly.

```
set(gca,'PlotBoxAspectRatio',[2,1,1])
```

See `LineStyleSpec` for a list of line styles and marker types.

### Combining Stem Plots with Line Plots

Sometimes it is useful to display more than one plot simultaneously with a stem plot to show how you arrived at a result. For example, create a linearly spaced vector with 60 elements and define two functions, `a` and `b`.

```
x = linspace(0,2*pi,60);  
a = sin(x);  
b = cos(x);
```

Create a stem plot showing the linear combination of the two functions.

```
stem_handles = stem(x,a+b);
```

Overlaying `a` and `b` as line plots helps visualize the functions. Before plotting the two curves, set `hold` to `on` so MATLAB does not clear the stem plot.

```
hold on  
plot_handles = plot(x,a,'--r',x,b,'--g');  
hold off
```

Use `legend` to annotate the graph. The stem and plot handles passed to `legend` identify which lines to label. Stem plots are composed of two lines; one draws the markers and the other draws the vertical stems. To create the legend, use the first handle returned by `stem`, which identifies the marker line.

```
legend_handles = [stem_handles(1);plot_handles];  
legend(legend_handles,'a + b','a = sin(x)','b = cos(x)')
```

Labeling the axes and creating a title finishes the graph.

```
xlabel('Time in \musecs')  
ylabel('Magnitude')  
title('Linear Combination of Two Functions')
```



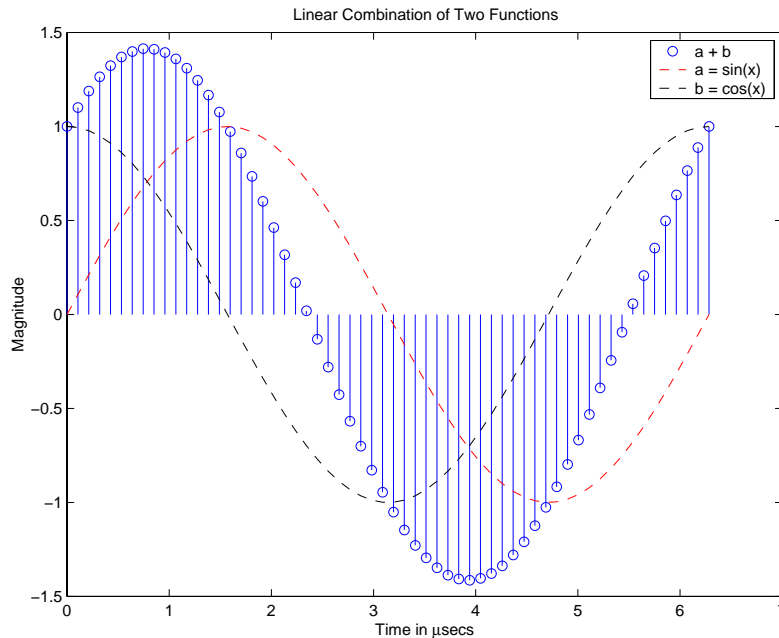

## Three-Dimensional Stem Plots

`stem3` displays 3-D stem plots extending from the  $xy$ -plane. With only one vector argument, MATLAB plots the stems in one row at  $x = 1$  or  $y = 1$ , depending on whether the argument is a column or row vector. `stem3` is intended to display data that you cannot visualize in a 2-D view.

### Example – 3-D Stem Plot of an FFT

For example, fast Fourier transforms are calculated at points around the unit circle on the complex plane. So, it is interesting to visualize the plot around the unit circle. Calculating the unit circle

```
th = (0:127)/128*2*pi;
x = cos(th);
y = sin(th);
```

and the magnitude frequency response of a step function

```
f = abs(fft(ones(10,1),128));
```

displays the data using a 3-D stem plot, terminating the stems with filled diamond markers.

```
stem3(x,y,f,'d','fill')  
view([-65 30])
```

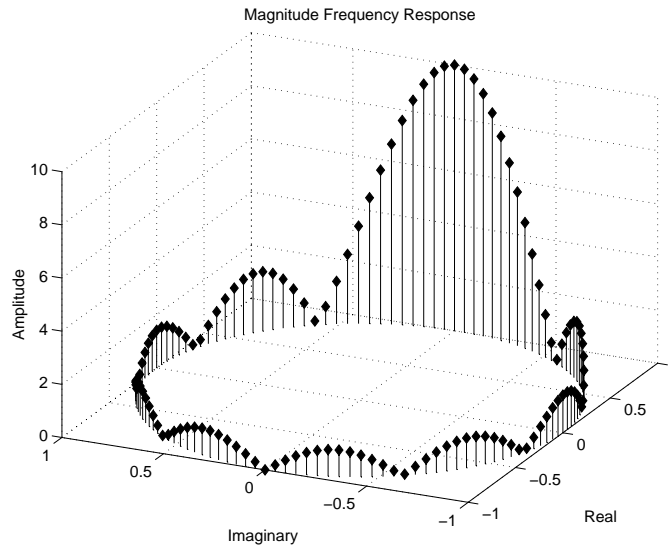

### Label the Graph

Label the graph with the statements

```
xlabel('Real')  
ylabel('Imaginary')  
zlabel('Amplitude')  
title('Magnitude Frequency Response')
```

To change the orientation of the view, turn on mouse-based 3-D rotation.

```
rotate3d on
```

### Example – Combining Stem and Line Plots

Three-dimensional stem plots work well when visualizing discrete functions that do not output a large number of data points. For example, you can use `stem3` to visualize the Laplace transform basis function,  $y = e^{-st}$ , for a particular constant value of  $s$ .

```
t = 0:.1:10;% Time limits
s = 0.1+i;% Spiral rate
y = exp(-s*t);% Compute decaying exponential
```

Using  $t$  as magnitudes that increase with time, create a spiral with increasing height and draw a curve through the tops of the stems to improve definition.

```
stem3(real(y),imag(y),t)
hold on
plot3(real(y),imag(y),t,'r')
hold off
view(-39.5,62)
```

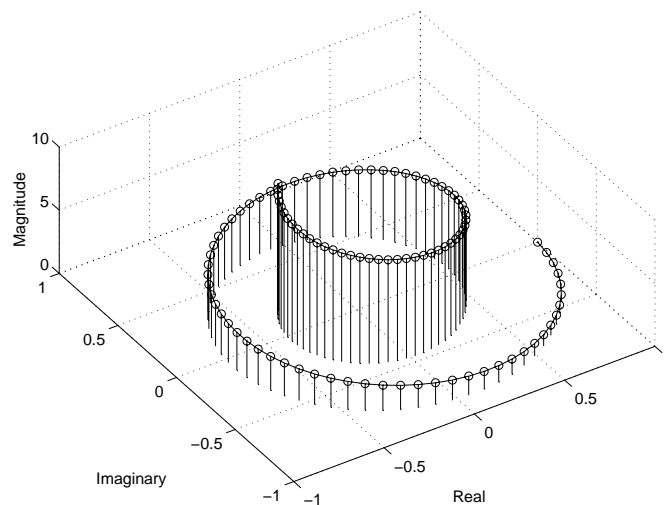

### Label the Graph

Add axes labels, with the statements

```
xlabel('Real')
```

```
ylabel('Imaginary')
xlabel('Magnitude')
```

### Stairstep Plots

Stairstep plots display data as the leading edges of a constant interval (i.e., zero-order hold state). This type of plot holds the data at a constant  $y$ -value for all values between  $x(i)$  and  $x(i+1)$ , where  $i$  is the index into the  $x$  data. This type of plot is useful for drawing time-history plots of digitally sampled data systems.

#### Example – Stairstep Plot of a Function

For example, define a function  $f$  that varies over time,

```
alpha = 0.01;
beta = 0.5;
t = 0:10;
f = exp(-alpha*t).*sin(beta*t);
```

Use `stairs` to display the function as a stairstep plot and a linearly interpolated function.

```
stairs(t,f)
hold on
plot(t,f,'-.*')
hold off
```

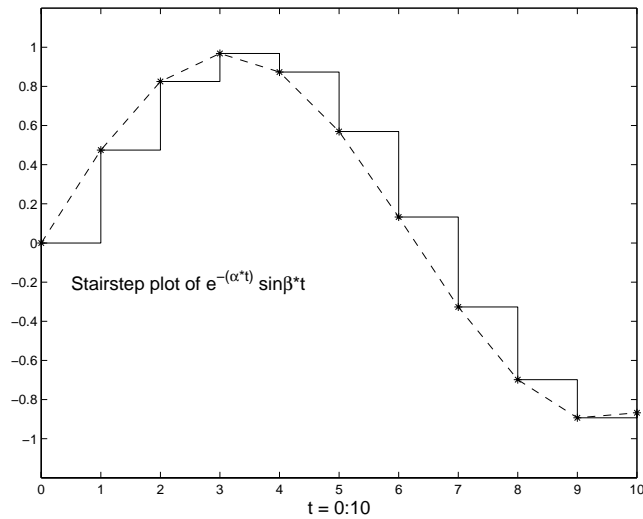

Annotate the graph and set the axes limits.

```
label = 'Stairstep plot of e^{-(\alpha*t)} sin\beta*t';  
text(0.5,-0.2,label,'FontSize',14)  
xlabel('t = 0:10','FontSize',14)  
axis([0 10 -1.2 1.2])
```

## Direction and Velocity Vector Graphs

Several MATLAB functions display data consisting of direction vectors and velocity vectors. This section describes these functions.

### Vector Plotting Commands

Function	Description
compass	Displays vectors emanating from the origin of a polar plot.
feather	Displays vectors extending from equally spaced points along a horizontal line.
quiver	Displays 2-D vectors specified by (u,v) components.
quiver3	Displays 3-D vectors specified by (u,v,w) components.

You can define the vectors using one or two arguments. The arguments specify the  $x$  and  $y$  components of the vectors relative to the origin.

If you specify two arguments, the first specifies the  $x$  components of the vectors and the second the  $y$  components of the vectors. If you specify one argument, the functions treat the elements as complex numbers. The real parts are the  $x$  components and the imaginary parts are the  $y$  components.

### Compass Plots

The compass function shows vectors emanating from the origin of a graph. The function takes Cartesian coordinates and plots them on a circular grid.

#### Example – Compass Plot of Wind Direction and Speed

This example shows a compass plot indicating the wind direction and strength during a 12-hour period. Two vectors define the wind direction and strength.

```
wdir = [45 90 90 45 360 335 360 270 335 270 335 335];
knots = [6 6 8 6 3 9 6 8 9 10 14 12];
```

Convert the wind direction, given as angles, into radians before converting the wind direction into Cartesian coordinates.

```
rdir = wdir * pi/180;
[x,y] = pol2cart(rdir,knots);
compass(x,y)
```

Wind Direction and Strength at  
Logan Airport for  
Nov. 3 at 1800 through  
Nov. 4 at 0600

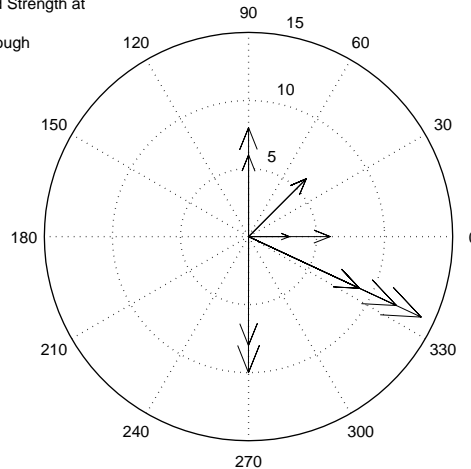

Create text to annotate the graph.

```
desc = {'Wind Direction and Strength at',
        'Logan Airport for ',
        'Nov. 3 at 1800 through',
        'Nov. 4 at 0600'};
text(-28,15,desc)
```

## Feather Plots

The feather function shows vectors emanating from a straight line parallel to the  $x$ -axis. For example, create a vector of angles from  $90^\circ$  to  $0^\circ$  and a vector the same size, with each element equal to 1.

```
theta = 90:-10:0;
r = ones(size(theta));
```

Before creating a feather plot, transform the data into Cartesian coordinates and increase the magnitude of  $r$  to make the arrows more distinctive.

```
[u,v] = pol2cart(theta*pi/180,r*10);
feather(u,v)
axis equal
```

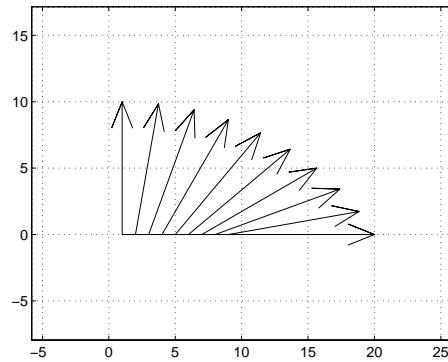

### Plotting Complex Numbers

If the input argument,  $Z$ , is a matrix of complex numbers, `feather` interprets the real parts of  $Z$  as the  $x$  components of the vectors and the imaginary parts as the  $y$  components of the vectors.

```
t = 0:0.5:10;    % Time limits
s = 0.05+i;      % Spiral rate
Z = exp(-s*t);  % Compute decaying exponential
feather(Z)
```

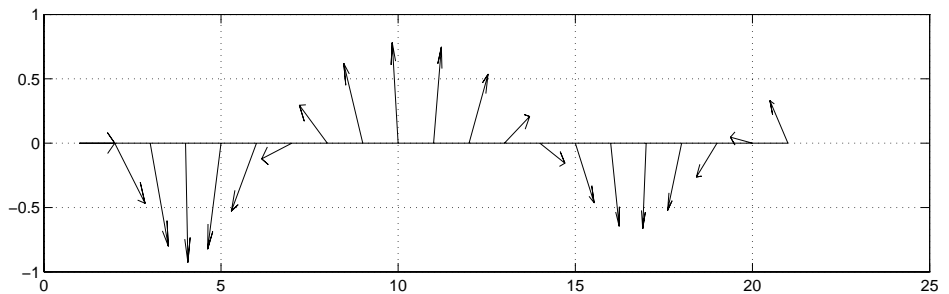



### Printing the Graph

This particular graph looks better if you change the figure's aspect ratio by stretching the figure lengthwise using the mouse. However, to maintain this shape in the printed output, set the figure's `PaperPositionMode` to `auto`.

```
set(gcf, 'PaperPositionMode', 'auto')
```

In this mode, MATLAB prints the figure as it appears on screen.

### Two-Dimensional Quiver Plots

The quiver function shows vectors at given points in two-dimensional space. The vectors are defined by  $x$  and  $y$  components.

A quiver plot is useful when displayed with another plot. For example, create 10 contours of the peaks function (see the “Contour Plots” section for more information).

```
n = -2.0:.2:2.0;  
[X,Y,Z] = peaks(n);  
contour(X,Y,Z,10)
```

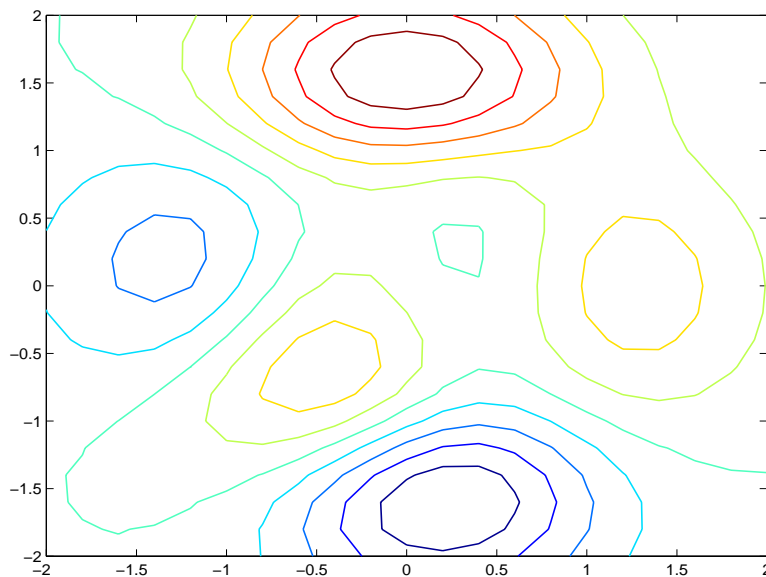

Now use gradient to create the vector components to use as inputs to quiver.

```
[U,V] = gradient(Z, .2);
```

Set hold to on and add the contour plot.

```
hold on
quiver(X,Y,U,V)
hold off
```

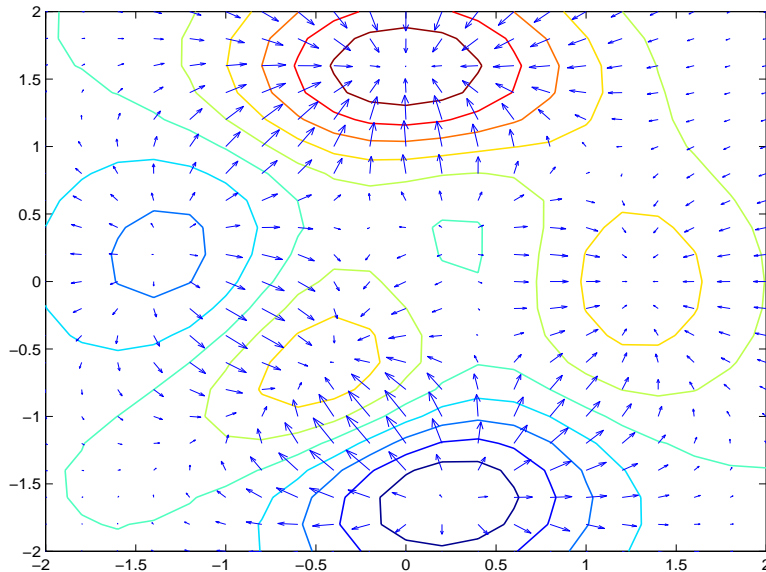

## Three-Dimensional Quiver Plots

Three-dimensional quiver plots (quiver3) display vectors consisting of (u,v,w) components at (x,y,z) locations. For example, you can show the path of a projectile as a function of time,

$$z(t) = v_z t + \frac{at^2}{2}$$

First, assign values to the constants  $v_z$  and  $a$ .

```
vz = 10;           % Velocity
a = -32;          % Acceleration
```

Then, calculate the height  $z$ , as time varies from 0 to 1 in increments of 0.1.

```
t = 0:.1:1;  
z = vz*t + 1/2*a*t.^2;
```

Calculate the position in the  $x$  and  $y$  directions.

```
vx = 2;  
x = vx*t;  
vy = 3;  
y = vy*t;
```

Compute the components of the velocity vectors and display the vectors using the 3-D quiver plot.

```
u = gradient(x);  
v = gradient(y);  
w = gradient(z);  
scale = 0;  
quiver3(x,y,z,u,v,w,scale)  
view([70 18])
```

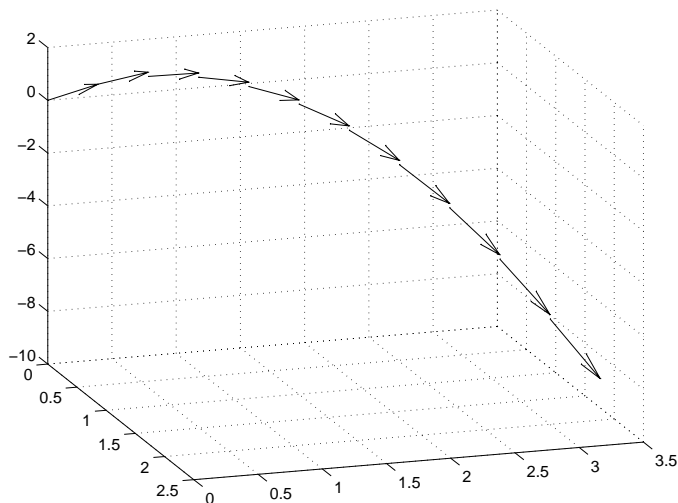

## Contour Plots

The contour functions create, display, and label isolines determined by one or more matrices.

### Contour Plotting Commands

Function	Description
<code>clabel</code>	Generates labels using the contour matrix and displays the labels in the current figure.
<code>contour</code>	Displays 2-D isolines generated from values given by a matrix <code>Z</code> .
<code>contour3</code>	Displays 3-D isolines generated from values given by a matrix <code>Z</code> .
<code>contourf</code>	Displays a 2-D contour plot and fills the area between the isolines with a solid color.
<code>contourc</code>	Low-level function to calculate the contour matrix used by the other contour functions.

Two other functions also create contours. `meshc` displays a contour in addition to a mesh, and `surfz` displays a contour in addition to a surface.

### Creating Simple Contour Plots

`contour` and `contour3` display 2- and 3-D contours, respectively. They require only one input argument — a matrix interpreted as heights with respect to a plane. In this case, the contour functions determine the number of contours to display based on the minimum and maximum data values.

To explicitly set the number of contour levels displayed by the functions, you specify a second optional argument.

### Contour Plot of the Peaks Function

The statements,

```
[X,Y,Z] = peaks;  
contour(X,Y,Z,20)
```

display 20 contours of the peaks function in a 2-D view.

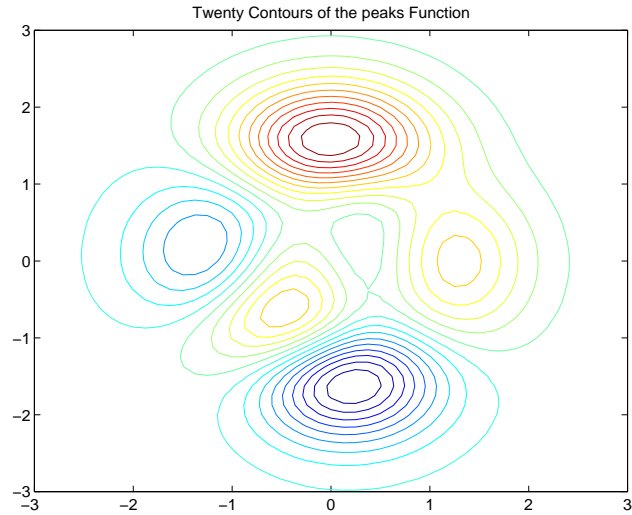

The statements

```
[X,Y,Z] = peaks;  
contour3(X,Y,Z,20)  
h = findobj('Type','patch');  
set(h,'LineWidth',2)  
title('Twenty Contours of the peaks Function')
```

display 20 contours of the peaks function in a 3-D view and increase the line width to 2 points.

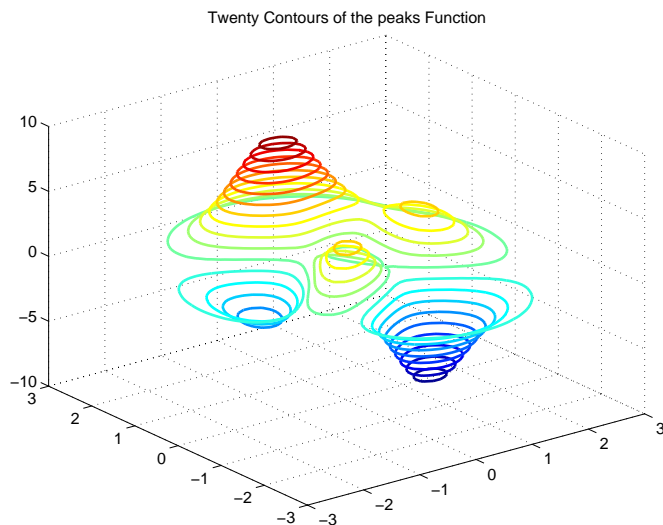

## Labeling Contours

Each contour level has a value associated with it. `clabel` uses these values to display labels for 2-D contour lines. The contour matrix contains the values `clabel` uses for the labels. This matrix is returned by `contour`, `contour3`, and `contourf` and is described in the “Contouring Algorithm” section.

`clabel` optionally returns the handles of the text objects used as labels. You can then use these handles to set the properties of the label string.

For example, display 10 contour levels of the peaks function,

```
Z = peaks;
[C,h] = contour(Z,10);
```

then label the contours and display a title.

```
clabel(C,h)
title({'Contour Labeled Using','clabel(C,h)'})
```

Note that `clabel` labels only those contour lines that are large enough to have an inline label inserted.

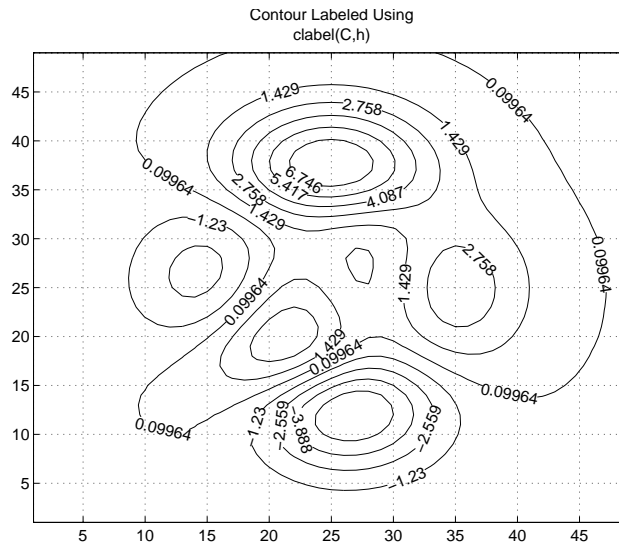

The 'manual' option enables you to add labels by selecting the contour you want to label with the mouse.

You can also use this option to label only those contours you select interactively.

For example,

```
clabel(C,h,'manual')
```

displays a crosshair cursor when your cursor is inside the figure. Pressing any mouse button labels the contour line closest to the center of the crosshair.

## Filled Contours

`contourf` displays a two-dimensional contour plot and fills the areas between contour lines. Use `caxis` to control the mapping of contour to color. For example, this filled contour plot of the peaks data uses `caxis` to map the fill colors into the center of the colormap.

```
Z = peaks;  
[C,h] = contourf(Z,10);  
caxis([-20 20])
```

```
title({'Filled Contour Plot Using','contourf(Z,10)'})
```

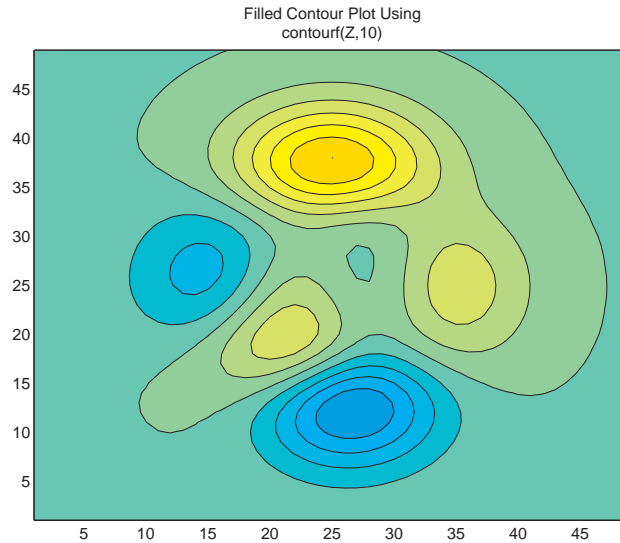

## Drawing a Single Contour Line at a Desired Level

The contouring functions permit you to specify the number of contour levels or the particular contour levels to draw. In the case of `contour`, the two forms of the function are `contour(Z,n)` and `contour(Z,v)`.  $Z$  is the data matrix,  $n$  is the number of contour lines, and  $v$  is a vector of specific contour levels.

MATLAB does not differentiate between a scalar and a one-element vector. So, if  $v$  is a one-element vector specifying a single contour at that level, `contour` interprets it as the number of contour lines, not the contour level.

Consequently, `contour(Z,v)` behaves in the same manner as `contour(Z,n)`.

To display a single contour line, define  $v$  as a two-element vector with both elements equal to the desired contour level. For example, create a 3-D contour of the peaks function.

```
xrange = -3:.125:3;
yrange = xrange;
[X,Y] = meshgrid(xrange,yrange);
```



```
Z = peaks(X,Y);
contour3(X,Y,Z)
```

To display only one contour level at  $Z = 1$ , define  $v$  as  $[1 \ 1]$ .

```
v = [1 1]
contour3(X,Y,Z,v)
```

## The Contouring Algorithm

The `contourc` function calculates the contour matrix for the other contour functions. It is a low-level function that is not called from the command line.

The contouring algorithm first determines which contour levels to draw. If you specified the input vector  $v$ , the elements of  $v$  are the contour level values, and `length(v)` determines the number of contour levels generated. If you do not specify  $v$ , the algorithm chooses no more than 20 contour levels that are divisible by 2 or 5.

The contouring algorithm treats the input matrix  $Z$  as a regularly spaced grid, with each element connected to its nearest neighbors. The algorithm scans this matrix comparing the values of each block of four neighboring elements (i.e., a cell) in the matrix to the contour level values. If a contour level falls within a cell, the algorithm performs a linear interpolation to locate the point at which the contour crosses the edges of the cell. The algorithm connects these points to produce a segment of a contour line.

`contour`, `contour3`, and `contourf` return a two-row matrix specifying all the contour lines. The format of the matrix is

```
C = [   value1   xdata(1)   xdata(2)...
       numv     ydata(1)   ydata(2)...]
```

The first row of the column that begins each definition of a contour line contains the value of the contour, as specified by  $v$  and used by `clabel`. Beneath that value is the number of  $(x,y)$  vertices in the contour line. Remaining

columns contain the data for the (x,y) pairs. For example, the contour matrix calculated by `C = contour(peaks(3))` is

Three vertices at $v = -0.2$	Columns 1 through 7	-0.2000	1.8165	2.0000	2.1835	0	1.0003	2.0000
		3.0000	1.0000	1.0367	1.0000	3.0000	1.0000	1.1998
	Columns 8 through 14	3.0000	0	1.0000	1.0359	1.0000	0.2000	1.6669
Three vertices at $v = 0$		1.0002	3.0000	2.9991	2.0000	1.0018	5.0000	3.0000
	Columns 15 through 21	1.2324	2.0000	2.8240	2.3331	0.4000	2.0000	2.6130
		2.0000	1.3629	2.0000	3.0000	5.0000	2.8530	2.0000
	Columns 22 through 28	2.0000	1.4290	2.0000	0.6000	2.0000	2.4020	2.0000
		1.5261	2.0000	2.8530	5.0000	2.5594	2.0000	1.6892
	Columns 29 through 35	1.6255	2.0000	0.8000	2.0000	2.1910	2.0000	1.8221
Five vertices at $v = 0.8$		2.0000	2.5594	5.0000	2.2657	2.0000	1.8524	2.0000
	Column 36	2.0000						
		2.2657						

The circled values begin each definition of a contour line.

## Changing the Offset of a Contour

The `surf` and `meshc` functions display contours beneath a surface or a mesh plot. These functions draw the contour plot at the axes' minimum z-axis limit. To specify your own offset, you must change the `ZData` values of the contour lines. First, save the handles of the graphics objects created by `meshc` or `surf`.

```
h = meshc(peaks(20));
```

The first handle belongs to the mesh or surface. The remaining handles belong to the contours you want to change. To raise the contour plane, add 2 to the z coordinate of each contour line.

```
for i = 2:length(h);
```

```

        newz = get(h(i), 'Zdata') + 2;
        set(h(i), 'Zdata', newz)
    end

```

## Displaying Contours in Polar Coordinates

You can contour data defined in the polar coordinate system. As an example, set up a grid in polar coordinates and convert the coordinates to Cartesian coordinates,

```

[th,r] = meshgrid((0:5:360)*pi/180,0:.05:1);
[X,Y] = pol2cart(th,r);

```

Then, generate the complex matrix  $Z$  on the interior of the unit circle,

```

Z = X+i*Y;

```

$X$ ,  $Y$ , and  $Z$  are points inside the circle.

Create and display a surface of the function  $\sqrt[4]{Z^4 - 1}$ .

```

f = (Z.^4-1).^(1/4);
surf(X,Y,abs(f))

```

Display the unit circle beneath the surface using the statements

```

hold on
surf(X,Y,zeros(size(X)))
hold off

```

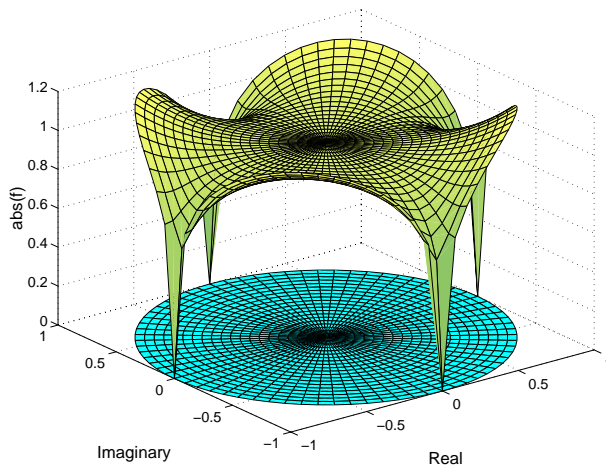

### Labeling the Graph

These statements add labels.

```
xlabel('Real','FontSize',14);  
ylabel('Imaginary','FontSize',14);  
zlabel('abs(f)','FontSize',14);
```

### Contours in Cartesian Coordinates

These statements display a contour of the surface in Cartesian coordinates and label the  $x$ - and  $y$ -axis.

```
contour(X,Y,abs(f),30)  
axis equal  
xlabel('Real','FontSize',14);  
ylabel('Imaginary','FontSize',14);
```

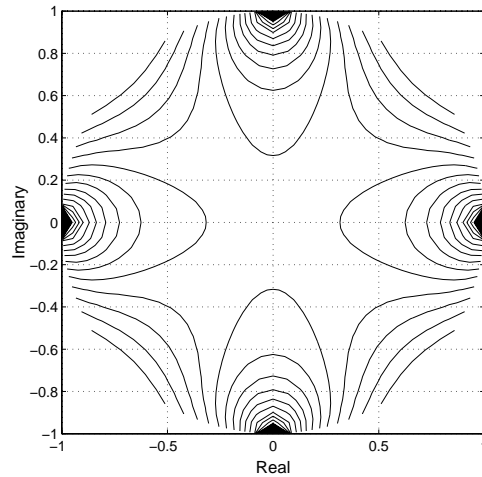

### Contours on a Polar Axis

You can also display the contour within a polar axes. Create a polar axes using the `polar` function, and then delete the line specified with `polar`.

```
h = polar([0 2*pi], [0 1]);  
delete(h)
```

With `hold on`, display the contour on the polar grid.

```
hold on  
contour(X,Y,abs(f),30)
```

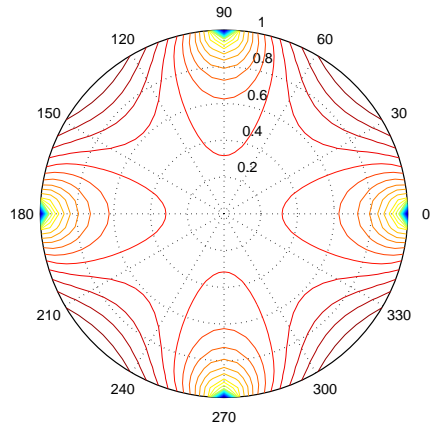

## Interactive Plotting

The `ginput` function enables you to use the mouse or the arrow keys to select points to plot. `ginput` returns the coordinates of the pointer's position; either the current position or the position when a mouse button or key is pressed. See the `ginput` function for more information.

### Example – Selecting Plotting Points from the Screen

This example illustrates the use of `ginput` with the `spline` function to create a curve by interpolating in two dimensions.

First, select a sequence of points,  $[x, y]$ , in the plane with `ginput`. Then pass two, one-dimensional splines through the points, evaluating them with a spacing  $1/10$  of the original spacing.

```
axis([0 10 0 10])
hold on
% Initially, the list of points is empty.
xy = [];
n = 0;
% Loop, picking up the points.
disp('Left mouse button picks points.')
disp('Right mouse button picks last point.')
but = 1;
while but == 1
    [xi,yi,but] = ginput(1);
    plot(xi,yi,'ro')
    n = n+1;
    xy(:,n) = [xi;yi];
end
% Interpolate with a spline curve and finer spacing.
t = 1:n;
ts = 1: 0.1: n;
xys = spline(t,xy,ts);

% Plot the interpolated curve.
plot(xys(1,:),xys(2,:),'b-');
hold off
```

This plot shows some typical output.

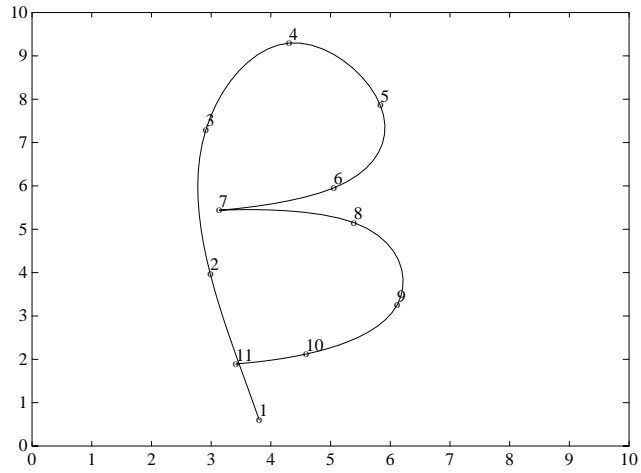



## Animation

You can create animated sequences with MATLAB in two different ways:

- Save a number of different pictures and then play them back as a movie.
- Continually erase and then redraw the objects on the screen, making incremental changes with each redraw.

Movies are better suited to situations where each frame is fairly complex and cannot be redrawn rapidly. You create each movie frame in advance so the original drawing time is not important during playback, which is just a matter of blitting the frame to the screen. A movie is not rendered in real-time; it is simply a playback of previously rendered frames.

The second technique, drawing, erasing, and then redrawing, makes use of different drawing modes supported by MATLAB. These modes allow faster redrawing at the expense of some rendering accuracy, so you must consider which mode to select.

This section provides an example of each technique. To see more sophisticated demonstrations of these features, type `demo` at the MATLAB prompt and explore the animation demonstrations.

### Movies

You can save any sequence of graphs and then play the sequence back in a short movie. There are two steps to this process:

- Use `getframe` to generate each movie frame.
- Use `movie` to run the movie a specified number of times at the specified rate.

Typically, you use `getframe` in a `for` loop to assemble the array of movie frames. `getframe` returns a structure having the following fields:

- `cdata` – image data in a `uint8` matrix. The matrix has dimensions of height-by-width on indexed-color systems and height-by-width-by-3 on truecolor systems.
- `colormap` – the colormap in an `n-by-3` matrix, where `n` is the number of colors. On truecolor systems, the `colormap` field is empty.

See `image` for more information on images.

## Example – Visualizing an FFT as a Movie

This example illustrates the use of movies to visualize the quantity  $\text{fft}(\text{eye}(n))$ , which is a complex  $n$ -by- $n$  matrix whose elements are various powers of the  $n$ th root of unity,  $\exp(i*2*\pi/n)$ .

### Creating the Movie

Create the movie in a for loop calling `getframe` to capture the graph. Since the `plot` command resets the axes properties, call `axis equal` within the loop before `getframe`.

```
for k = 1:16
    plot(fft(eye(k+16)))
    axis equal
    M(k) = getframe;
end
```

### Running the Movie

After generating the movie, you can play it back any number of times. To play it back 30 times, type

```
movie(M,30)
```

You can readily generate and smoothly play back movies with a few dozen frames on most computers. Longer movies require large amounts of primary memory or a very effective virtual memory system.

### Movies that Include the Entire Figure

If you want to capture the contents of the entire figure window (for example, to include GUI components in the movie), specify the figure's handle as an argument to the `getframe` command. For example, suppose you want to add a slider to indicate the value of  $k$  in the previous example.

```
h = uicontrol('style','slider','position',...
    [10 50 20 300],'Min',1,'Max',16,'Value',1)
for k = 1:16
    plot(fft(eye(k+16)))
    axis equal
    set(h,'Value',k)
    M(k) = getframe(gcf);
end
```

In this example, the movie frame contains the entire figure. To play so that it looks like the original figure, make the playback axes fill the figure window.

```
clf
axes('Position',[0 0 1 1])
movie(M,30)
```

## Erase Modes

You can select the method MATLAB uses to redraw graphics objects. One event that causes MATLAB to redraw an object is changing the properties of that object. You can take advantage of this behavior to create animated sequences. A typical scenario is to draw a graphics object, then change its position by respecifying the  $x$ ,  $y$ , and  $z$ -coordinate data by a small amount with each pass through a loop.

You can create different effects by selecting different erase modes. This section illustrates how to use the three modes that are useful for dynamic redrawing:

- none – MATLAB does not erase the objects when it is moved.
- background – MATLAB erases the object by redrawing it in the background color. This mode erases the object and anything below it (such as grid lines).
- xor – This mode erases only the object and is usually used for animation.

All three modes are faster (albeit less accurate) than the normal mode used by MATLAB.

### Example – Animating with Erase Modes

It is often interesting and informative to see 3-D trajectories develop in time. This example involves chaotic motion described by a nonlinear differential equation known as the Lorenz strange attractor. It can be written

in the form  $\frac{dy}{dt} = Ay$

with a vector valued function  $y(t)$  and a matrix  $A$ , which depends upon  $y$ .

$$A(y) = \begin{bmatrix} \frac{8}{3} & 0 & y(2) \\ 0 & -10 & 10 \\ -y(2) & 28 & -1 \end{bmatrix}$$

The solution orbits about two different attractive points without settling into a steady orbit about either. This example approximates the solution with the simplest possible numerical method – Euler’s method with fixed step size. The result is not very accurate, but it has the same qualitative behavior as other methods.

```
A = [ -8/3 0 0; 0 -10 10; 0 28 -1 ];
y = [35 -10 -7]';
h = 0.01;
p = plot3(y(1),y(2),y(3),'.', ...
          'EraseMode','none','MarkerSize',5); % Set EraseMode to none
axis([0 50 -25 25 -25 25])
hold on
for i=1:4000
    A(1,3) = y(2);
    A(3,1) = -y(2);
    ydot = A*y;
    y = y + h*ydot;
    % Change coordinates
    set(p,'XData',y(1),'YData',y(2),'ZData',y(3))
    drawnow
    i=i+1;
end
```

The `plot3` statement sets `EraseMode` to `none`, indicating that the points already plotted should not be erased when the plot is redrawn. In addition, the handle of the plot object is saved. Within the `for` loop, a `set` statement references the plot object and changes its internally stored coordinates for the new location. While this manual cannot show the dynamically evolving output, this picture shows a snapshot.

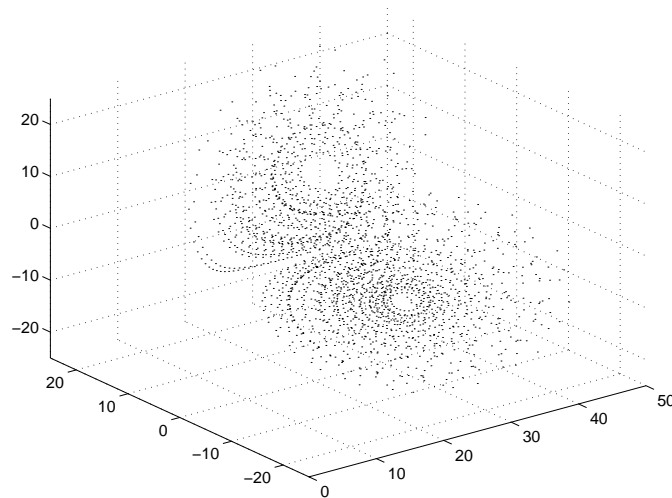

Note that, as far as MATLAB is concerned, the graph created by this example contains only one dot. What you see on the screen are remnants of previous plots that MATLAB has been instructed not to erase. The only way to print this graph from MATLAB is with a screen capture. You can use the capture command to generate a MATLAB image of the figure window contents.

**Background Erase Mode.** To see the effect of EraseMode background, add these statements to the previous program.

```
p = plot3(y(1),y(2),y(3),'square', ...
    'EraseMode','background','MarkerSize',10,...
    'MarkerEdgeColor',[1 .7 .7],'MarkerFaceColor',[1 .7 .7]);

for i=1:4000
    A(1,3) = y(2);
    A(3,1) = -y(2);
    ydot = A*y;
    y = y + h*ydot;
    set(p,'XData',y(1),'YData',y(2),'ZData',y(3))
    drawnow
    i=i+1;
```

```
end  
hold off
```

Since `hold` is still on, this code erases the previously created graph by setting the `EraseMode` property to `background` and changing the marker to a “pink eraser” (a square marker colored pink).

**Xor Erase Mode.** If you change the `EraseMode` of the first `plot3` statement from `none` to `xor`, you will see a moving dot (Marker `'.'`) only. Xor mode is used to create animations where you do not want to leave remnants of previous graphics on the screen.

### Additional Examples

The MATLAB demo, `lorenz`, provides a more accurate numerical approximation, and a more elaborate display of Lorenz strange attractor example. Other MATLAB demos illustrate animation techniques.

# Displaying Bit-Mapped Images

---

<b>Overview</b> . . . . .	5-2
<b>Images in MATLAB</b> . . . . .	5-4
<b>Image Types</b> . . . . .	5-6
<b>Working with 8-Bit and 16-Bit Images</b> . . . . .	5-11
<b>Reading, Writing, and Querying Graphics Image Files</b> . . . . .	5-15
<b>Displaying Graphics Images</b> . . . . .	5-18
<b>The Image Object and Its Properties</b> . . . . .	5-23
<b>Printing Images</b> . . . . .	5-28
<b>Converting the Data or Graphic Type of Images</b> . . . . .	5-29

## Overview

MATLAB provides commands for reading, writing, and displaying several types of graphics file formats for images. As with MATLAB-generated images, once a graphics file format image is displayed, it becomes a Handle Graphics image object. MATLAB supports the following graphics file formats:

- BMP (Microsoft Windows Bitmap)
- HDF (Hierarchical Data Format)
- JPEG (Joint Photographic Experts Group)
- PCX (Paintbrush)
- PNG (Portable Network Graphics)
- TIFF (Tagged Image File Format)
- XWD (X Window Dump)

For information concerning the bit depths and image types supported for these formats, see `imread` and `imwrite`.

MATLAB supports three different numeric classes for image display: double-precision floating-point (`double`), 16-bit unsigned integer (`uint16`), and 8-bit unsigned integer (`uint8`). The image display commands interpret data values differently depending on the numeric class the data is stored in.

This chapter discusses the different data and image types you can use, and includes details on how to: read, write, work with, and display graphics images; how to alter the display properties and aspect ratio of an image during display; how to print an image; and how to convert the data type or graphics format of an image.

This table lists the functions discussed in this chapter.

Function	Purpose	Function Group
<code>axis</code>	Plot axis scaling and appearance	Display
<code>image</code>	Display image (create image object)	Display
<code>imagesc</code>	Scale data and display as image	Display
<code>imread</code>	Read image from graphics file	File I/O



---

<b>Function</b>	<b>Purpose</b>	<b>Function Group</b>
imwrite	Write image to graphics file	File I/O
imfinfo	Get image information from graphics file	Utility
ind2rgb	Convert indexed image to RGB image	Utility

## Images in MATLAB

The basic data structure in MATLAB is the *array*, an ordered set of real or complex elements. This object is naturally suited to the representation of *images*, real-valued, ordered sets of color or intensity data. (MATLAB does not support complex-valued images.)

MATLAB stores most images as two-dimensional arrays (i.e., matrices), in which each element of the matrix corresponds to a single pixel in the displayed image. For example, an image composed of 200 rows and 300 columns of different colored dots would be stored in MATLAB as a 200-by-300 matrix. Some images, such as RGB, require a three-dimensional array, where the first plane in the 3rd dimension represents the red pixel intensities, the second plane represents the green pixel intensities, and the third plane represents the blue pixel intensities.

This convention makes working with graphics file format images in MATLAB similar to working with any other type of matrix data. For example, you can select a single pixel from an image matrix using normal matrix subscripting.

```
I(2,15)
```

This command returns the value of the pixel at row 2, column 15 of the image I.

### Bit Depth Support

MATLAB supports reading the most commonly used bit depths (bits per pixel) of any of the supported graphics file formats. When the data is in memory, it can be stored as `uint8`, `uint16`, or `double`. For details on which bit depths are appropriate for each supported format, see `imread` and `imwrite`.

### Data Types

This section introduces you to the different data types that MATLAB uses to store images. Details on the inner workings of the storage for 8- and 16-bit images are included in “Working with 8-Bit and 16-Bit Images”.

By default, MATLAB stores most data in arrays of class `double`. The data in these arrays is stored as double precision (64-bit) floating-point numbers. All of MATLAB’s functions and capabilities work with these arrays.

For images stored in one of the graphics file formats supported by MATLAB, however, this data representation is not always ideal. The number of pixels in

such an image may be very large; for example, a 1000-by-1000 image has a million pixels. Since each pixel is represented by at least one array element, this image would require about 8 megabytes of memory if it were stored as class `double`.

To reduce memory requirements, MATLAB supports storing image data in arrays of class `uint8` and `uint16`. The data in these arrays is stored as 8-bit or 16-bit unsigned integers. These arrays require one-eighth or one-fourth as much memory as data in `double` arrays.

## Image Types

In MATLAB, an image consists of a data matrix and possibly a colormap matrix. Three basic image types are used in MATLAB, each differing in the way that the data matrix elements are interpreted:

- Indexed images
- Intensity (or grayscale) images
- RGB (or truecolor) images

This section discusses how MATLAB represents each of these image types.

### Indexed Images

An indexed image consists of a data matrix,  $X$ , and a colormap matrix,  $map$ .  $map$  is an  $m$ -by-3 array of class `double` containing floating-point values in the range  $[0, 1]$ . Each row of  $map$  specifies the red, green, and blue components of a single color. An indexed image uses “direct mapping” of pixel values to colormap values. The color of each image pixel is determined by using the corresponding value of  $X$  as an index into  $map$ . The value 1 points to the first row in  $map$ , the value 2 points to the second row, and so on. You can display an indexed image with the statements

```
image(X); colormap(map)
```

A colormap is often stored with an indexed image and is automatically loaded with the image when you use the `imread` function. However, you are not limited to using the default colormap—you can use any colormap that you choose. The description for the property `CDataMapping` describes how to alter the type of mapping used.

The next figure illustrates the structure of an indexed image. The pixels in the image are represented by integers, which are pointers (indices) to color values stored in the colormap.

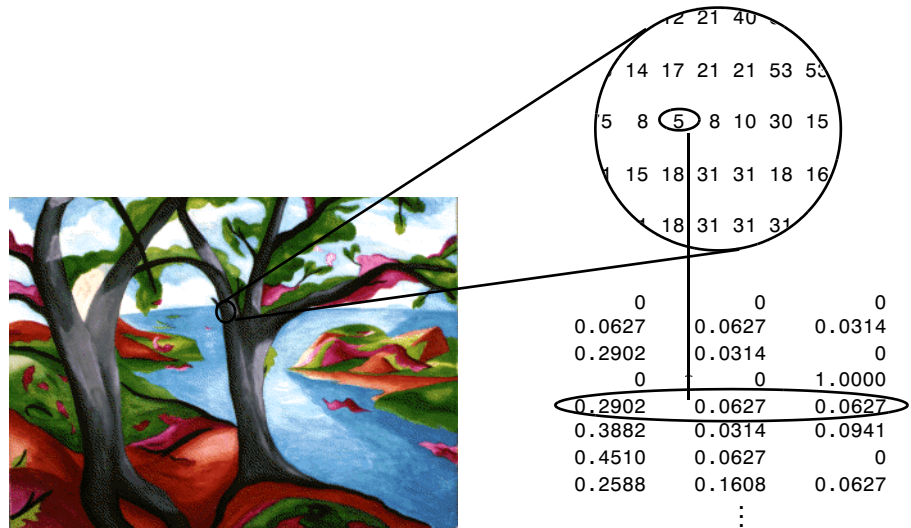

The relationship between the values in the image matrix and the colormap depends on the class of the image matrix. If the image matrix is of class `double`, the value 1 points to the first row in the colormap, the value 2 points to the second row, and so on. If the image matrix is of class `uint8` or `uint16`, there is an offset—the value 0 points to the first row in the colormap, the value 1 points to the second row, and so on. The offset is also used in graphics file formats, to maximize the number of colors that can be supported. In the image above, the image matrix is of class `double`. Because there is no offset, the value 5 points to the fifth row of the colormap.

## Intensity Images

An intensity image is a data matrix,  $I$ , whose values represent intensities within some range. MATLAB stores an intensity image as a single matrix, with each element of the matrix corresponding to one image pixel. The matrix can be of class `double`, `uint8`, or `uint16`. While intensity images are rarely saved with a colormap, MATLAB uses a colormap to display them. In essence, MATLAB handles intensity images as indexed images.

This figure depicts an intensity image of class `double`.

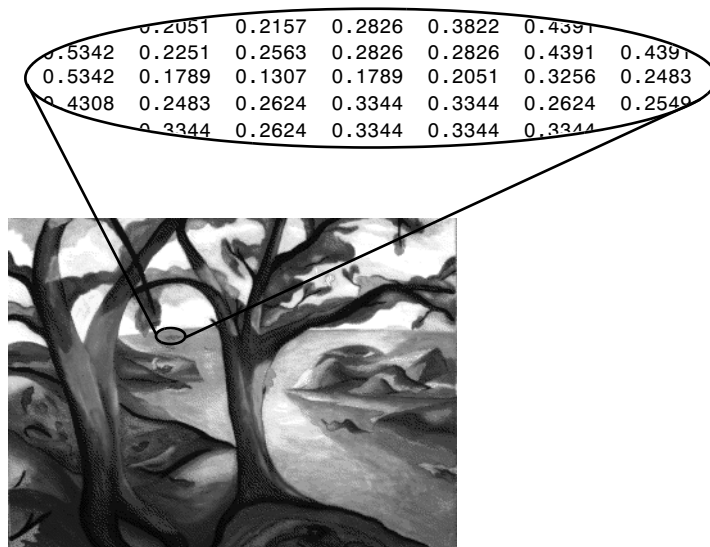

To display an intensity image, use the `imagesc` (“image scale”) function, which enables you to set the range of intensity values. `imagesc` scales the image data to use the full colormap. Use the two-input form of `imagesc` to display an intensity image. For example,

```
imagesc(I,[0 1]); colormap(gray);
```

The second input argument to `imagesc` specifies the desired intensity range. The function `imagesc` displays `I` by mapping the first value in the range (usually 0) to the first colormap entry, and the second value (usually 1) to the last colormap entry. Values in between are linearly distributed throughout the remaining colormap colors.

Although it is conventional to display intensity images using a grayscale colormap, it is possible to use other colormaps. For example, the following statements display the intensity image `I` in shades of blue and green.

```
imagesc(I,[0 1]); colormap(winter);
```

To display a matrix `A` with an arbitrary range of values as an intensity image, use the single-argument form of `imagesc`. With one input argument, `imagesc` maps the minimum value of the data matrix to the first colormap entry, and

maps the maximum value to the last colormap entry. For example, these two lines are equivalent.

```
imagesc(A); colormap(gray)
imagesc(A,[min(A(:)) max(A(:))]); colormap(gray)
```

## RGB (Truecolor) Images

An RGB image, sometimes referred to as a “truecolor” image, is stored in MATLAB as an  $m$ -by- $n$ -by-3 data array that defines red, green, and blue color components for each individual pixel. RGB images do not use a palette. The color of each pixel is determined by the combination of the red, green, and blue intensities stored in each color plane at the pixel’s location. Graphics file formats store RGB images as 24-bit images, where the red, green, and blue components are 8 bits each. This yields a potential of 16 million colors. The precision with which a real-life image can be replicated has led to the nickname “truecolor image”.

An RGB MATLAB array can be of class `double`, `uint8`, or `uint16`. In an RGB array of class `double`, each color component is a value between 0 and 1. A pixel whose color components are (0,0,0) displays as black, and a pixel whose color components are (1,1,1) displays as white. The three color components for each pixel are stored along the third dimension of the data array. For example, the red, green, and blue color components of the pixel (10,5) are stored in `RGB(10,5,1)`, `RGB(10,5,2)`, and `RGB(10,5,3)`, respectively.

To display the truecolor image `RGB`, use the `image` function. For example,

```
image(RGB)
```

If MATLAB is running on a computer that does not have hardware support for truecolor image display, MATLAB uses color approximation and dithering to display an approximation of the image. See “Dithering Truecolor on Indexed Color Systems” for more information.

The next figure shows an RGB image of class `double`.

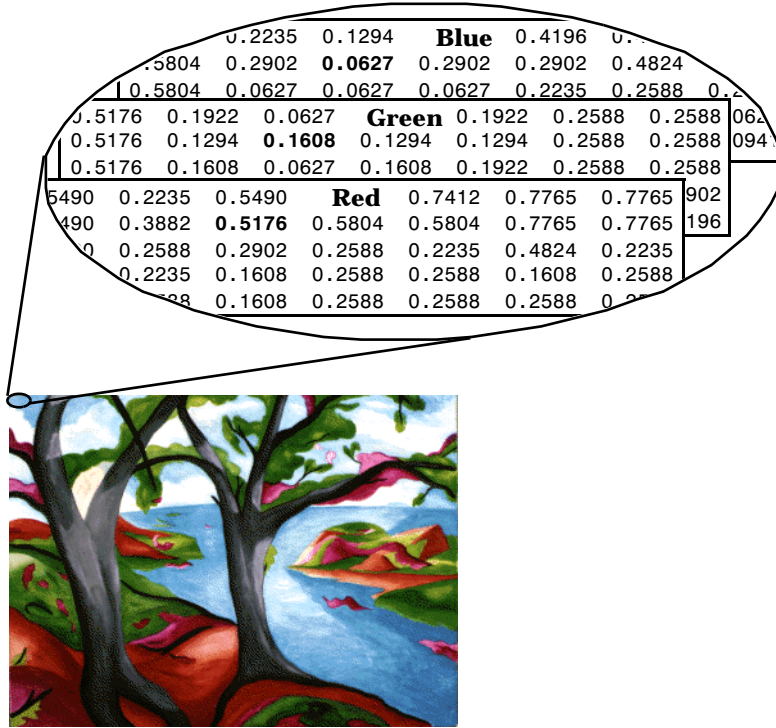

To determine the color of the pixel at (2,3), you would look at the RGB triplet stored in (2,3,1:3). Suppose (2,3,1) contains the value 0.5176, (2,3,2) contains 0.1608, and (2,3,3) contains 0.0627. The color for the pixel at (2,3) is

0.5176 0.1608 0.0627



## Working with 8-Bit and 16-Bit Images

MATLAB usually works with double-precision (64-bit) floating-point numbers. However, to reduce memory requirements for working with images, MATLAB provides limited support for storing images as 8-bit or 16-bit unsigned integers by using the numeric classes `uint8` or `uint16`, respectively. An image whose data matrix has class `uint8` is called an 8-bit image; an image whose data matrix has class `uint16` is called a 16-bit image.

The `image` function can display 8- or 16-bit images directly without converting them to double precision. However, `image` interprets matrix values slightly differently when the image matrix is `uint8` or `uint16`. The specific interpretation depends on the image type.

### 8-Bit and 16-Bit Indexed Images

If the class of `X` is `uint8` or `uint16`, its values are offset by one before being used as colormap indices. The value 0 points to the first row of the colormap, the value 1 points to the second row, and so on. The `image` command automatically supplies the proper offset, so the display method is the same whether `X` is `double`, `uint8`, or `uint16`.

```
image(X); colormap(map);
```

The colormap index offset for `uint8` and `uint16` data is intended to support standard graphics file formats, which typically store image data in indexed form with a 256-entry colormap. The offset allows you to manipulate and display images of this form in MATLAB using the more memory-efficient `uint8` and `uint16` arrays.

Because of the offset, you must add 1 to convert a `uint8` or `uint16` indexed image to `double`. For example,

```
X64 = double(X8) + 1;  
or  
X64 = double(X16) + 1;
```

Conversely, subtract 1 to convert a `double` indexed image to `uint8` or `uint16`.

```
X8 = uint8(X64 - 1);  
or  
X16 = uint16(X64 - 1);
```

The order of operations must be as shown, because most of MATLAB's mathematical operations cannot be performed on `uint8` and `uint16` arrays.

### 8-Bit and 16-Bit Intensity Images

Whereas the range of double image arrays is usually [0, 1], the range of 8-bit intensity images is usually [0, 255] and the range of 16-bit intensity images is usually [0, 65535]. Use the following command to display an 8-bit intensity image with a gray scale colormap.

```
imagesc(I,[0 255]); colormap(gray);
```

To convert an intensity image from double to `uint16`, first multiply by 65535.

```
I16 = uint16(round(I64*65535));
```

Conversely, divide by 65535 after converting a `uint16` intensity image to double.

```
I64 = double(I16)/65535;
```

### 8-Bit and 16-Bit RGB Images

The color components of an 8-bit RGB image are integers in the range [0, 255] rather than floating-point values in the range [0, 1]. A pixel whose color components are (255,255,255) displays as white. The `image` command displays an RGB image correctly whether its class is double, `uint8`, or `uint16`.

```
image( RGB );
```

To convert an RGB image from double to `uint8`, first multiply by 255.

```
RGB8 = uint8(round(RGB64*255));
```

Conversely, divide by 255 after converting a `uint8` RGB image to double.

```
RGB64 = double(RGB8)/255
```

To convert an RGB image from double to `uint16`, first multiply by 65535.

```
RGB16 = uint16(round(RGB64*65535));
```

Conversely, divide by 65535 after converting a `uint16` RGB image to double.

```
RGB64 = double(RGB16)/65535;
```

## Mathematical Operations Support for uint8 and uint16

The following MATLAB mathematical operations support `uint8` and `uint16` data: `conv2`, `convn`, `fft2`, `fftn`, `sum`. In these cases, the output is always `double`.

If you attempt to perform an unsupported operation on one of these arrays, you will receive an error. For example,

```
BW3 = BW1 + BW2
??? Function '+' not defined for variables of class 'uint8'.
```

Most of the functions in the Image Processing Toolbox accept `uint8` and `uint16` input. If you plan to do sophisticated image processing on `uint8` or `uint16` data, you should consider adding the Image Processing Toolbox to your MATLAB computing environment.

## Other 8-Bit and 16-Bit Array Support

MATLAB supports several other operations on `uint8` and `uint16` arrays, including:

- Reshaping, reordering, and concatenating arrays using the functions `reshape`, `cat`, `permute`, and the `[]` and `'` operators
- Saving and loading `uint8` and `uint16` arrays in MAT-files using `save` and `load`. (Remember that if you are loading or saving a graphics file format image, you must use the commands `imread` and `imwrite`, instead.)
- Locating the indices of nonzero elements in `uint8` and `uint16` arrays using `find`. However, the returned array is always of class `double`.
- Relational operators

## Summary of Image Types and Numeric Classes

This table summarizes the way MATLAB interprets data matrix elements as pixel colors, depending on the image type and data class.

Image Type	double Data	uint8 or uint16 Data
Indexed	Image is an $m$ -by- $n$ array of integers in the range $[1, p]$ .  Colormap is a $p$ -by-3 array of floating-point values in the range $[0, 1]$ .	Image is an $m$ -by- $n$ array of integers in the range $[0, p - 1]$ .  Colormap is a $p$ -by-3 array of floating-point values in the range $[0, 1]$ .
Intensity	Image is an $m$ -by- $n$ array of floating-point values that are linearly scaled by MATLAB to produce colormap indices. The typical range of values is $[0, 1]$ .  Colormap is a $p$ -by-3 array of floating-point values in the range $[0, 1]$ and is typically grayscale.	Image is an $m$ -by- $n$ array of integers that are linearly scaled by MATLAB to produce colormap indices. The typical range of values is $[0, 255]$ or $[0, 65535]$ .  Colormap is a $p$ -by-3 array of floating-point values in the range $[0, 1]$ and is typically grayscale.
RGB (Truecolor)	Image is an $m$ -by- $n$ -by-3 array of floating-point values in the range $[0, 1]$ .	Image is an $m$ -by- $n$ -by-3 array of integers in the range $[0, 255]$ or $[0, 65535]$ .

## Reading, Writing, and Querying Graphics Image Files

In its native form, a graphics file format image is not stored as a MATLAB matrix, or even necessarily as a matrix. Most graphics files begin with a header containing format-specific information tags, and continue with bitmap data that can be read as a continuous stream. For this reason, you cannot use the standard MATLAB I/O commands `load` and `save` to read and write a graphics file format image.

MATLAB provides special functions for reading and writing image data from graphics file formats. To read a graphic file format image use `imread`; to write a graphic file format image, use `imwrite`; to obtain information about the nature of a graphics file format image, use `imfinfo`.

This table gives a clearer picture of which MATLAB commands should be used with which image types.

Procedure	Function(s) to Use
Load or Save a Matrix as a MAT-file	<code>load</code> <code>save</code>
Load or Save Graphics File Format Image, e.g. BMP, TIFF	<code>imread</code> <code>imwrite</code>
Display Any Image Loaded Into MATLAB	<code>image</code> <code>imagesc</code>
Utilities	<code>imfinfo</code> <code>ind2rgb</code>

### Reading a Graphics Image

The function `imread` reads an image from any supported graphics image file in any of the supported bit depths. Most of the images that you will read are 8-bit. When these are read into memory, MATLAB stores them as class `uint8`. The main exception to this rule is that MATLAB supports 16-bit data for PNG and TIFF images. If you read a 16-bit PNG or TIFF image, it will be stored as class `uint16`.

---

**Note** For indexed images, `imread` always reads the colormap into an array of class `double`, even though the image array itself may be of class `uint8` or `uint16`.

---

For our discussion here we will show one of the most basic syntax uses of `imread`. This code reads the image `ngc6543a.jpg`.

```
RGB = imread('ngc6543a.jpg');
```

You can write (save) image data using the `imwrite` function. The statements

```
load clown
imwrite(X,map,'clown.bmp')
```

create a BMP file containing the clown image.

### Writing a Graphics Image

When you save an image using `imwrite`, MATLAB's default behavior is to automatically reduce the bit depth to `uint8`. Many of the images used in MATLAB are 8-bit, and most graphics file format images do not require double-precision data. One exception to MATLAB's rule for saving the image data as `uint8` is that PNG and TIFF images may be saved as `uint16`. Since these two formats support 16-bit data, you may override MATLAB's default behavior by specifying `uint16` as the data type for `imwrite`. The following example shows writing a 16-bit PNG file using `imwrite`.

```
imwrite(I,'clown.png','BitDepth',16);
```

### Obtaining Information About Graphics Files

The `imfinfo` function enables you to obtain information about graphics files that are in any of the standard formats listed above. The information you obtain depends on the type of file, but it always includes at least the following:

- Name of the file, including the directory path if the file is not in the current directory
- File format
- Version number of the file format

- **File modification date**
- **File size in bytes**
- **Image width in pixels**
- **Image height in pixels**
- **Number of bits per pixel**
- **Image type: RGB (truecolor), intensity (grayscale), or indexed**

### Displaying Graphics Images

To display a graphics file image, use either `image` or `imagesc`. For example,

```
figure('Position',[100 100 size(RGB,2) size(RGB,1)]);  
image(RGB); set(gca,'Position',[0 0 1 1])
```

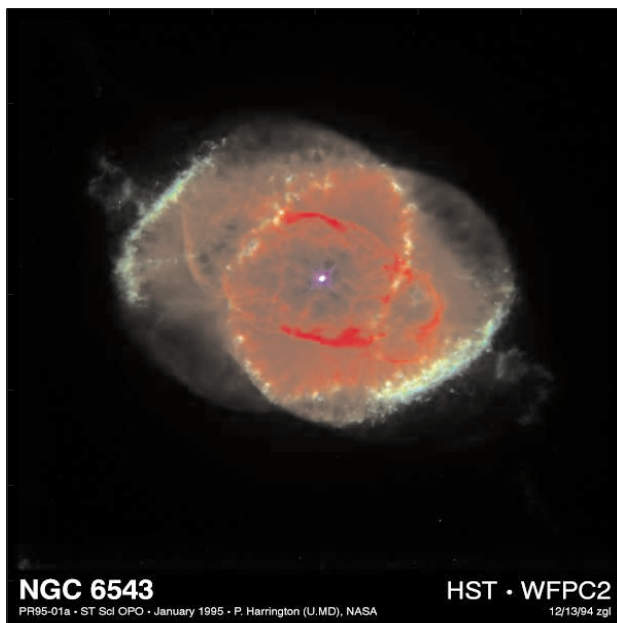

(This image was created with support to the Space Telescope Science Institute, operated by the Association of Universities for research in Astronomy, Inc., from NASA contract NAs5-26555, and is reproduced with permission from AURA/STScI. Digital renditions of images produced by AURA/STScI are obtainable royalty-free. Credits: J.P. Harrington and K.J. orkowski (University of Maryland), and NASA.)



## Summary of Image Types and Display Methods

This table summarizes display methods for the three types of images.

Image Type	Display Commands	Uses Colormap Colors
Indexed	<code>image(X); colormap(map)</code>	Yes
Intensity	<code>imagesc(I,[0 1]); colormap(gray)</code>	Yes
RGB (truecolor)	<code>image(RGB)</code>	No

## Controlling Aspect Ratio and Display Size

The `image` function displays the image in a default-sized figure and axes. MATLAB stretches or shrinks the image to fit the display area. Sometimes you want the aspect ratio of the display to match the aspect ratio of the image data matrix. The easiest way to do this is with the command `axis image`.

For example, these commands display the earth image in the `demos` directory using the default figure and axes positions.

```
load earth
image(X); colormap(map)
```

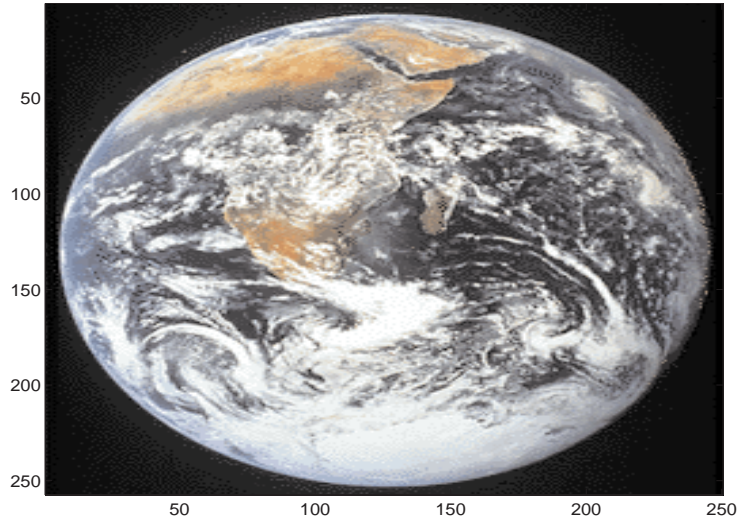

The elongated globe results from stretching the image display to fit the axes position. Use the `axis image` command to force the aspect ratio to be one-to-one.

```
axis image
```

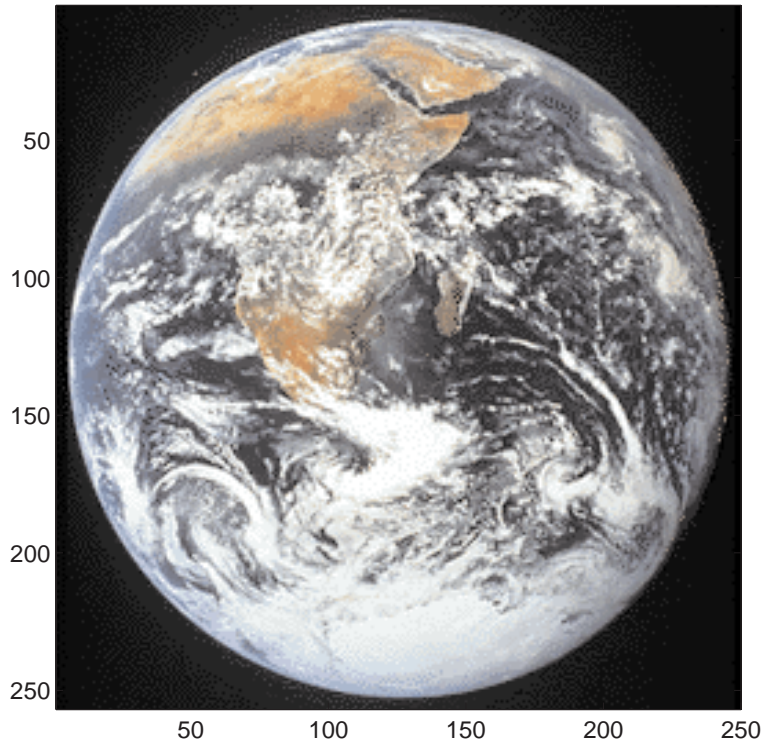

The command `axis image` works by setting the `DataAspectRatio` property of the axes object to `[1 1 1]`. See `axis` and `axes` for more information on how to control the appearance of axes objects.

Sometimes you may want to display an image so that each element in the data matrix corresponds to a single screen pixel. To display an image with this one-to-one, matrix-element-to-screen-pixel mapping, you need to resize the figure and axes. For example, these commands display the earth image so that one data element corresponds to one screen pixel.

```
[m,n] = size(X);  
figure('Units','pixels','Position',[100 100 n m])  
image(X); colormap(map)  
set(gca,'Position',[0 0 1 1])
```

The figure's `Position` property is a four-element vector that specifies the figure's location on the screen as well as its size. The second statement above positions the figure so that its lower-left corner is at position (100,100) on the screen and so that its width and height match the image width and height. Setting the axes position to [0 0 1 1] in normalized units creates an axes that fills the figure. The resulting picture is shown.

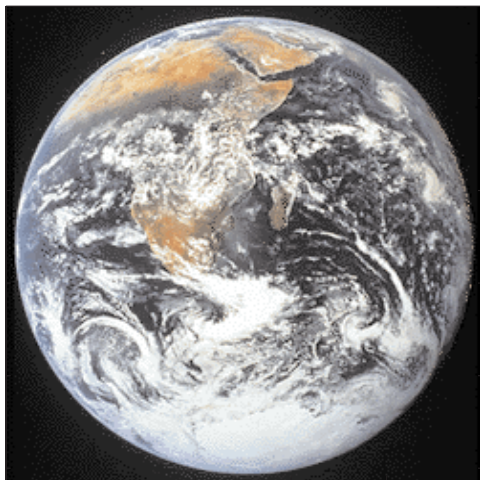

## The Image Object and Its Properties

The commands `image` and `imagesc` create image objects. Image objects are children of axes objects, as are line, patch, surface, and text objects. Like all Handle Graphics objects, the image object has a number of properties you can set to fine-tune its appearance on the screen. The most important properties of the image object with respect to appearance are `CData`, `CDataMapping`, `XData`, `YData`, and `EraseMode`. For detailed information about these and all of the properties of the image object, please see `image`.

### CData

The `CData` property of an image object contains the data array. In the commands below, `h` is the handle of the image object created by `image`, and the matrices `X` and `Y` are the same.

```
h = image(X); colormap(map)
Y = get(h, 'CData');
```

The dimensionality of the `CData` array controls whether MATLAB displays the image using `colormap` colors or as an RGB image. If the `CData` array is two-dimensional, then the image is either an indexed image or an intensity image, and in either case the image is displayed using `colormap` colors. If, on the other hand, the `CData` array is  $m$ -by- $n$ -by-3, then MATLAB displays it as a truecolor image, ignoring the `colormap` colors.

### CDataMapping

The `CDataMapping` property controls whether an image is indexed or intensity. An indexed image is displayed by setting the `CDataMapping` property to `'direct'`, in which case the values of the `CData` array are used directly as indices into the figure's `colormap`. When the `image` command is used with a single input argument, it sets the value of `CDataMapping` to `'direct'`.

```
h = image(X); colormap(map)
get(h, 'CDataMapping')
ans =

direct
```

Intensity images are displayed by setting the `CDataMapping` property to `'scaled'`. In this case the `CData` values are linearly scaled to form `colormap`

indices. The scale factors are controlled by the axes `CLim` property. The `imagesc` function creates an image object whose `CDataMapping` property is set to 'scaled', and it also adjusts the `CLim` property of the parent axes. For example,

```
h = imagesc(I,[0 1]); colormap(map)
get(h,'CDataMapping')
ans =

scaled

get(gca,'CLim')
ans =

[0 1]
```

### XData and YData

The `XData` and `YData` properties control the coordinate system of the image. For an  $m$ -by- $n$  image, the default `XData` is `[1 n]` and the default `YData` is `[1 m]`. These settings imply the following:

- The left column of the image has an  $x$ -coordinate of 1.
- The right column of the image has an  $x$ -coordinate of  $n$ .
- The top row of the image has a  $y$ -coordinate of 1.
- The bottom row of the image has a  $y$ -coordinate of  $m$ .

For example, the statements,

```
X = [1 2 3 4; 5 6 7 8; 9 10 11 12];
h = image(X); colormap(colorcube(12))
xlabel x; ylabel y
```

produce the picture.

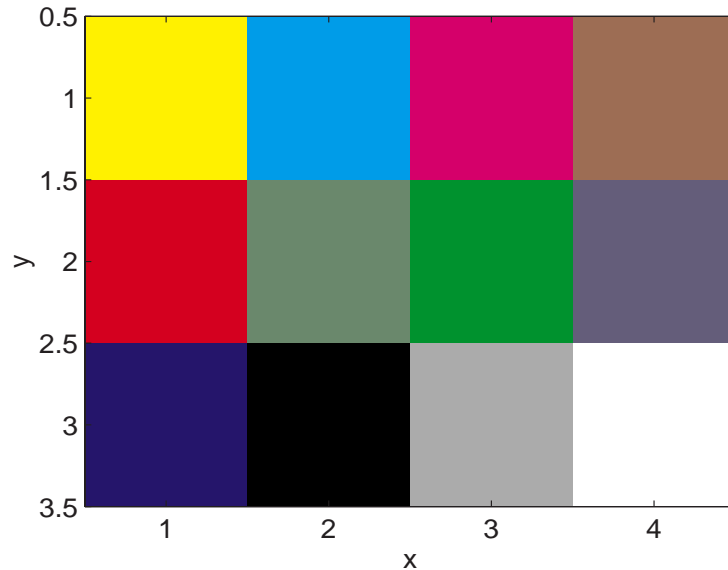

The XData and YData properties of the resulting image object have the default values shown below.

```
get(h,'XData')
ans =
```

```
1 4
```

```
get(h,'YData')
ans =
```

```
1 3
```

However, you can override the default settings to specify your own coordinate system. For example, the statements,

```
X = [1 2 3 4; 5 6 7 8; 9 10 11 12];
image(X,'XData',[-1 2],'YData',[2 4]); colormap(colorcube(12))
xlabel x; ylabel y
```

produce the picture.

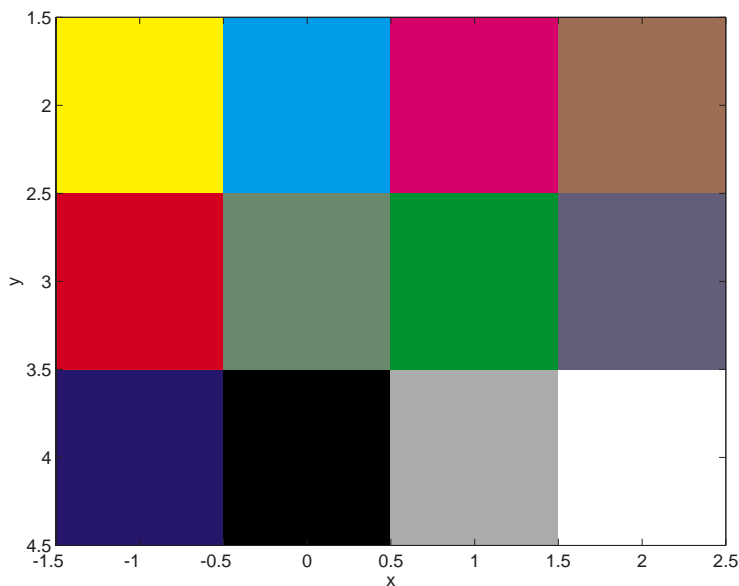

### EraseMode

The `EraseMode` property controls how MATLAB updates the image on the screen if the image object's `CData` property changes. The default setting of `EraseMode` is `'normal'`. With this setting, if you change the `CData` of the image object using the `set` command, MATLAB erases the image on the screen before redrawing the image using the new `CData` array. The erase step is a problem if you want to display a series of images quickly and smoothly.

You can achieve fast and visually smooth updates of displayed images as you change the image `CData` by setting the image object `EraseMode` property to `'none'`. With this setting, MATLAB does not take the time to erase the displayed image — it immediately draws the updated image when the `CData` changes.



Suppose, for example, that you have an  $m$ -by- $n$ -by-3-by- $x$  array  $A$ , containing  $x$  different truecolor images of the same size. You can display them dynamically with

```
h = image(A(:,:,:,1), 'EraseMode', 'none');
for i = 2:x
    set(h, 'CData', A(:,:,:,i))
    drawnow
end
```

Rather than creating a new image object each time through the loop, this code simply changes the `CData` of the image object (which was created on the first line using the `image` command). The `drawnow` command causes MATLAB to update the display with each pass through the loop. Because the image `EraseMode` is set to `'none'`, changes to the `CData` do not cause the image on the screen to erase each time through the loop.

## Printing Images

When you set the axes `Position` to `[0 0 1 1]` so that it fills the entire figure, the aspect ratio will not be preserved when you print because MATLAB adjusts the figure size when printing according to the figure's `PaperPosition` property. To preserve the image aspect ratio when printing, set the figure's `PaperPositionMode` to `'auto'` from the command line.

```
set(gcf, 'PaperPositionMode', 'auto')
print
```

When `PaperPositionMode` is set to `'auto'`, the width and height of the printed figure are determined by the figure's dimensions on the screen, and the figure position is adjusted to center the figure on the page. If you want the default value of `PaperPositionMode` to be `'auto'`, enter this line in your `startup.m` file.

```
set(0, 'DefaultFigurePaperPositionMode', 'auto')
```

## Converting the Data or Graphic Type of Images

Sometimes you will want to perform operations that are not supported for `uint8` or `uint16` arrays. To do this, convert the data to double precision using the `double` function. For example,

```
BW3 = double(BW1) + double(BW2);
```

Keep in mind that converting between data types changes the way MATLAB and the toolbox interpret the image data. If you want the resulting array to be interpreted properly as image data, you need to rescale or offset the data when you convert it. (See the earlier sections “Image Types” and “8-Bit and 16-Bit Indexed Images” for more information about offsets.)

For certain operations, it is helpful to convert an image to a different image type. For example, if you want to filter a color image that is stored as an indexed image, you should first convert it to RGB format. To do this efficiently, use the `ind2rgb` function. (which originated in the Image Processing Toolbox). When you apply the filter to the RGB image, MATLAB filters the intensity values in the image, as is appropriate. If you attempt to filter the indexed image, MATLAB simply applies the filter to the indices in the indexed image matrix, and the results may not be meaningful.

You can also perform certain conversions just using MATLAB syntax. For example, if you want to convert a grayscale image to RGB, you can concatenate three copies of the original matrix along the third dimension.

```
RGB = cat(3,I,I,I);
```

The resulting RGB image has identical matrices for the red, green, and blue planes, so the image displays as shades of gray.

Sometimes you will want to change the graphics format of an image, perhaps for compatibility with another software product. This process is very straightforward. For example, to convert an image from a BMP to a PNG, load the BMP using `imread`, set the data type to `uint8`, `uint16`, or `double`, and then save the image using `imwrite`, with 'PNG' specified as your target format. See `imread` and `imwrite` for the specifics of which bit depths are supported for the different graphics formats, and for how to specify the format type when writing an image to file.



# Basic Printing and Exporting

---

<b>Quick Start</b> . . . . .	6-3
<b>Overview of Printing and Exporting</b> . . . . .	6-22
<b>Printing a Figure to a Printer or a File</b> . . . . .	6-26
<b>Exporting a Figure in Graphics Format</b> . . . . .	6-47
<b>Troubleshooting</b> . . . . .	6-55

MATLAB enables you to do basic printing and exporting without having to understand handle graphics. This section describes some frequently used ways to print or export a MATLAB figure, and explains the basic printing and exporting interfaces.

### **Quick Start**

Step-by-step instructions for printing a figure to a printer or to a file, and for exporting a figure to a graphics-format file or to the clipboard

### **Overview of Printing and Exporting**

Selecting a figure to print or export, what is printed, and information about default settings

### **Printing a Figure to a Printer or to a File**

Printing a figure directly to a printer from the print menus or from the command line. You can also print to a file, and print that file to a printer at some later time.

### **Exporting a Figure in Graphics Format**

Exporting a figure in graphics-format, such as JPEG or, to a file that you can later import into another application. MATLAB enables you to export to a file from the print menus or from the command line. You can also export a figure to the clipboard from the preferences panels, and paste it from there into an application.

## Quick Start

This section provides step by step instructions for common printing and exporting tasks. Each printing example tells you how to perform the task from the print menus and from the command line. Some tasks can only be performed from the command line.

### List of Examples

#### Printing to a Printer

Print a figure directly to a printer:

- Using the defaults
- At screen size
- Locking the ticks and limits of the axes
- Setting the paper size
- Setting the size of and centering a figure
- To a nondefault printer
- Using Ghostscript

#### Printing to a File

- Printing a figure to a file. You can later print this file to a printer.
- Appending a figure to an existing PostScript file

#### Exporting

Export a figure in a graphics-format file that you can later import into an application:

- Using a specific graphics format
- In EPS color format with a TIFF preview
- To the clipboard (Windows only)

### Dialog Box Overview

If you want to print or export a figure using the figure menus, this diagram illustrates the relationships between the dialog boxes you use most often.

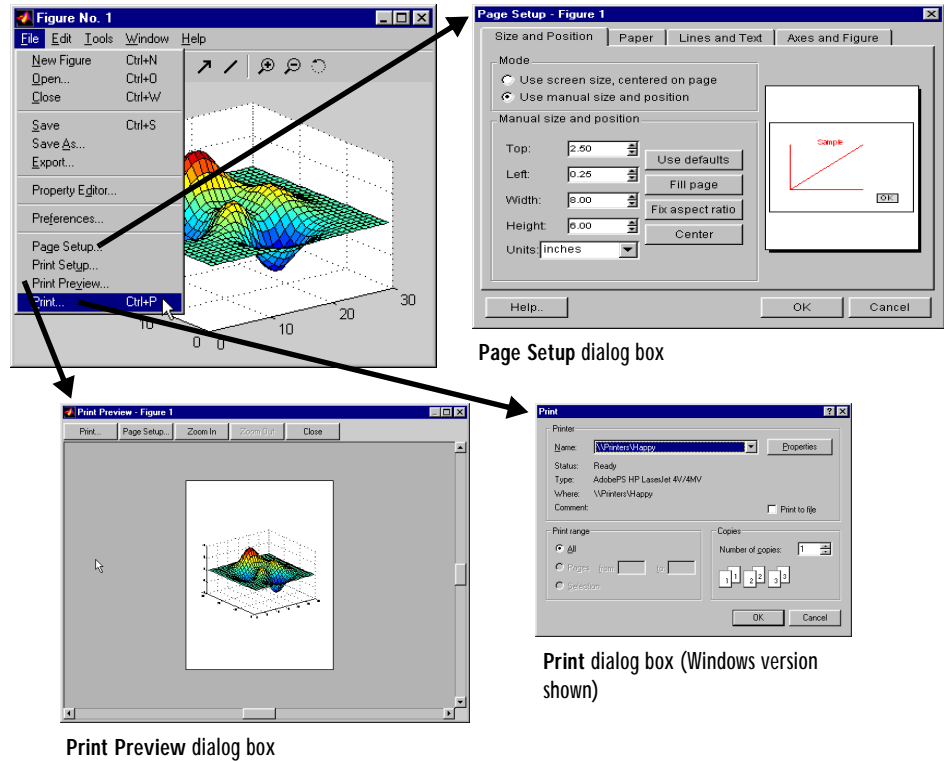

## Printing to a Printer Using the Defaults

If you have not changed the default settings, MATLAB prints the current figure 8-by-6 inches with no window frame. It centers the figure on portrait format 8.5-by-11 inch paper if available. MATLAB sets the figure background and the axes background to white, and scales the ticks and limits of your axes to accommodate the printed size.

This example shows how to print using the defaults:

- From the Windows menus
- From the UNIX menus
- From the command line



## From the Windows Menus

- 1 Select **Print** from the figure window's **File** menu. This invokes the **Print** dialog box.

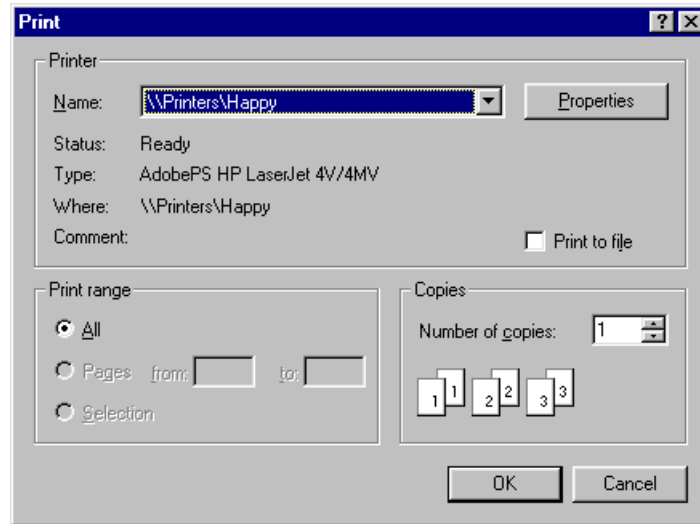

- 2 Choose a printer from the **Name** scroll list, if the printer you want to use is not already selected.
- 3 If desired, set the **Number of copies** to a value greater than 1.
- 4 Click **OK** to print.

## From the UNIX Menus

- 1 Select **Print** from the figure window's **File** menu. This invokes the **Print** dialog box.

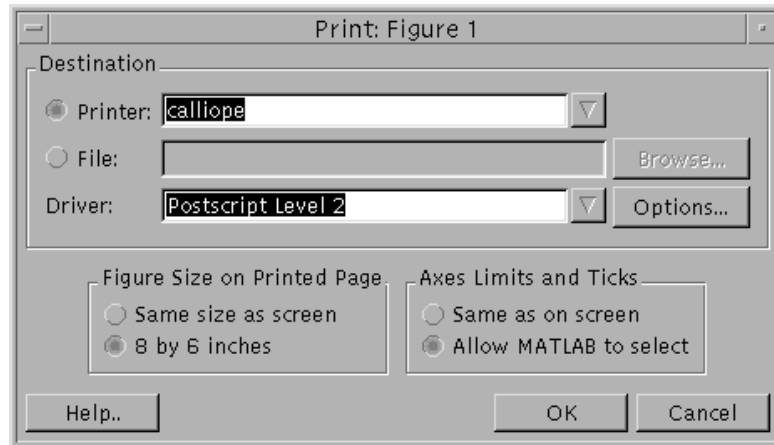

2 Set **Destination to Printer** and choose a printer name from the **Printer** list and a driver from the **Driver** list.

3 Click **OK** to print.

### From the Command Line

This example uses the most basic form of the print command. MATLAB uses the defaults to print the current figure to your default printer.

```
print
```

This example prints Figure No. 2 using default settings.

```
print -f2
```

### Printing to a Printer at Screen Size

By default, MATLAB prints your figure at 8-by-6 inches. This size includes the area delimited by the background. This example shows how to print or export it the same size it is displayed on your screen:

- From the Windows menus
- From the UNIX menus
- From the command line

### From the Windows Menus

- 1 Resize your figure window to the size you want it to be when printed.
- 2 Select **Page Setup** from the figure window's **File** menu and select the **Size and Position** tab.
- 3 In the **Mode** group box, select **Use screen size, centered on page**.
- 4 Click **OK**.
- 5 Invoke the **Print** dialog box to print the figure.

### From the UNIX Menus

- 1 Invoke the **Print** dialog box to print the figure.
- 2 In the **Figure Size on Printed Page** group box, select the **Same size as screen** option.
- 3 Click **OK**.

**Note.** You can also select screen size from the **Size and Position** tab in the **Page Setup** dialog box.

### From the Command Line

Set the `PaperPositionMode` property to `auto` before printing the figure.

```
set(gcf, 'PaperPositionMode', 'auto');  
print
```

If you later want to print the figure at its original size, set `PaperPositionMode` back to `'manual'`.

## Printing to a Printer, Locking the Ticks and Limits of the Axes

By default, MATLAB scales the ticks and limits of your axes to accommodate the printed size. This example shows how to lock them so they do not change:

- From the Windows menus

- From the UNIX menus
- From the command line

### From the Windows Menus

- 1 Select **Page Setup** from the figure window's **File** menu and select the **Axes and Figure** tab.
- 2 Select **Keep screen limits and ticks** in the **Axes limits and ticks** box.
- 3 Click **OK**.
- 4 Invoke the **Print** dialog box to print the figure.

### From the UNIX Menus

- 1 Invoke the **Print** dialog box to print the figure.
- 2 Select the **Same as on screen** option in the **Axes Limits and Ticks** group box.
- 3 Click **OK**.

**Note.** You can also select screen size from the **Axes and Figure** tab in the **Page Setup** dialog box.

### From the Command Line

Set the `xtickmode`, `ytickmode`, and `ztickmode` properties to `manual` before printing the figure.

```
set(gca, 'xtickmode','manual');  
set(gca, 'ytickmode','manual');  
set(gca, 'ztickmode','manual');  
print
```

## Printing to a Printer, Setting the Paper Size

By default, MATLAB uses 8.5-by-11 inch paper. This example shows how to change the paper size to 8.5-by-14 inches by selecting a paper type (Legal):

- From the Windows and UNIX menus
- From the command line

### From the Windows and UNIX Menus

- 1 Select **Page Setup** from the figure window's **File** menu.
- 2 Select the **Paper** tab.
- 3 Select the Legal paper type from the list under **Paper size**. The width and height fields update to 8.5 and 14, respectively.
- 4 Make sure that **Units** is set to **Inches**.
- 5 Click **OK**.
- 6 Invoke the **Print** dialog box to print the figure.

### From the Command Line

Set the PaperUnits property to inches, and the PaperType property to Legal.

```
set(gcf, 'PaperUnits', 'inches');  
set(gcf, 'PaperType', 'Legal');
```

Alternatively, you can set the PaperSize property to the size of the paper, in the specified units.

```
set(gcf, 'PaperUnits', 'inches');  
set(gcf, 'PaperSize', [8.5 14]);
```

## Printing to a Printer, Setting the Size of and Centering a Figure

This example sets the size of a figure to 5.5-by-3 inches and centers it on the paper:

- From the Windows and UNIX menus
- From the command line

### From the Windows and UNIX Menus

- 1 Select **Page Setup** from the figure window's **File** menu and select the **Size and Position** tab.
- 2 Make sure that **Use screen size, centered on page** is unchecked.
- 3 Enter 5.5 in the **Width** field and 3 in the **Height** field. (You can type these values or click the arrows to select the new size.)
- 4 Make sure that **Units** field is set to **Inches**.
- 5 Click **Center**.
- 6 Click **OK**.

### From the Command Line

- 1 Start by setting PaperUnits to inches.  

```
set(gcf, 'PaperUnits', 'inches')
```
- 2 Use PaperSize to return the size of the current paper.  

```
papersize = get(gcf, 'PaperSize')
```

```
papersize =  
      8.5000   11.0000
```
- 3 Initialize variables to the desired width and height of the figure.  

```
width = 5.5;           % Initialize a variable for width.  
height = 3;           % Initialize a variable for height.
```
- 4 Calculate a left margin that centers the figure horizontally on the paper. Use the first element of PaperSize (width of paper) for the calculation.  

```
left = (PaperSize(1) - width) / 2
```

```
left =  
      1.5000
```

- 5 Calculate a bottom margin that centers the figure vertically on the paper. Use the second element of `PaperSize` (height of paper) for the calculation.

```
bottom = (PaperSize(2) - height)/2
```

```
bottom =  
    4
```

- 6 Set the figure size and print.

```
myfiguresize = [left, bottom, width, height];  
set(gcf, 'PaperPosition', myfiguresize);  
print
```

## Printing to a Nondefault Printer

This example shows you how to select a different printer on a per figure basis:

- From the Windows menus
- From the UNIX menus
- From the command line

**Note.** To set the default printer for the current MATLAB session, select **Print Setup** from the figure window's **File** menu. Under **Printer**, select a printer from the name list.

### From the Windows Menus

- 1 Select **Print** from the figure window's **File** menu. This invokes the **Print** dialog box.

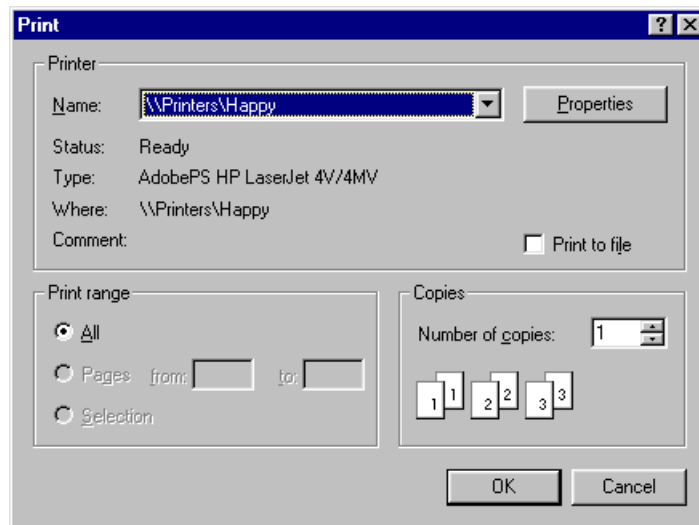

2 Choose a printer from the **Name** list, if the printer you want to use is not already selected.

3 Click **OK**.

### From the UNIX Menus

1 Select **Print** from the figure window's **File** menu. This invokes the **Print** dialog box.



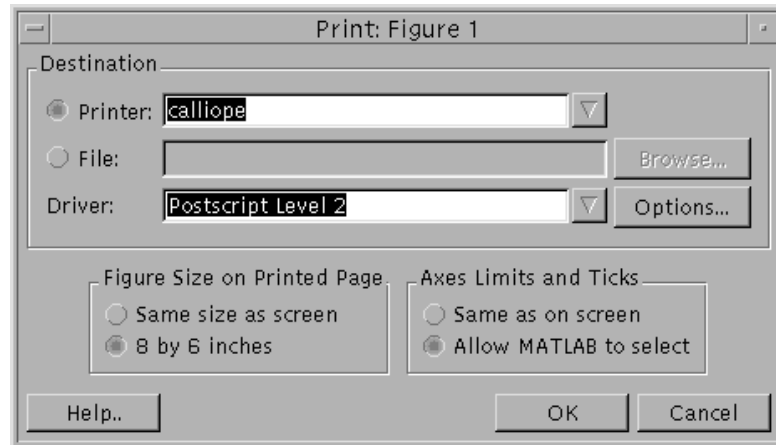

2 Set **Destination** to **Printer** and choose a printer name from the **Printer** list and a driver from the **Driver** list.

3 Click **OK**.

### From the Command Line (UNIX only)

This example sends the output to a black-and-white PostScript printer named homer.

```
print -dps -Phomer
```

## Printing to a Printer Using GhostScript

If you are using a non-PostScript printer, you may encounter an incompatibility that causes the figure to print incorrectly. For example, some parts of the figure may not print. In some cases, you can get by this problem by using a GhostScript driver:

- From the UNIX menus
- From the command line

---

**Note** See the print reference page for a list of GhostScript drivers. You cannot specify a printer driver from the Windows menus.

---

### From the UNIX Menus

- 1 Select **Print** from the figure window's **File** menu. This invokes the **Print** dialog box.
- 2 Set **Destination** to **Printer** and choose a printer name from the **Printer** list.
- 3 From the **Driver** list, select a GhostScript driver that is compatible with your printer. Click **OK** to print.

### From the Command Line

This example uses a GhostScript driver to send the output to the default printer, an HP LaserJet III. See the print reference page for a list of GhostScript drivers.

```
print -dljet3
```

## Printing a Figure to a File

This example shows you how to print a figure to a file for later printing. By default, the figure is saved in your current directory.

- From the Windows menus
- From the UNIX menus
- From the command line

### From the Windows Menus

- 1 Select **Print** from the figure window's **File** menu. This invokes the **Print** dialog box.
- 2 Select a printer, from the **Name** list, which is of the same type as the one to which you will later print the figure.

- 3 Select the **Print to File** check box.
- 4 Click **OK**. This invokes the **Print to File** dialog box.
- 5 Enter a filename, preceding it with a pathname if you do not want the file saved to the current directory.
- 6 Click **OK** to save the file.

### From the UNIX Menus

- 1 Select **Print** from the figure window's **File** menu. This invokes the **Print** dialog box.
- 2 Set **Destination** to **File** and enter a filename in the **Name** field. If you need to specify a directory other than the current directory, use the **Browse** button to navigate to the desired directory.
- 3 Use the **Driver** scroll list to select a MATLAB printer driver for the type of printer to which you will later print the figure.
- 4 Click **OK** to save the file.

### From the Command Line

This example prints the figure in PostScript format to a file called `myfigure.ps`.

```
print myfigure.ps;
```

This example uses GhostScript to print the figure to a file named `myfigure.jet` that can later be printed to an HP LaserJet III. MATLAB adds the appropriate file extension.

```
print -dljet3 myfigure;
```

---

**Note** See the print reference page for a list of printer drivers and their MATLAB calls.

---

### Appending a Figure to a PostScript File

Use the `print` command with the `-append` option to include more than one PostScript-format figure in a single PostScript file. When you print the resulting file, each figure appears on a separate page.

This example appends the figure, in PostScript format, to the PostScript file, `myfile`.

```
print -dps -append myfile
```

This command appends Figure No. 2 to a file named `myfigs.ps` using level 1 color PostScript format.

```
print -dpsc -f2 -append myfigs.ps
```

---

**Note** See the `print` reference page for a list of printer drivers and their MATLAB calls.

---

### Exporting a Figure to a File in a Specific Graphics Format

Export a figure to a graphics-format file when you want to import it at a later time into another application such as a word processor.

- From the Windows or UNIX menus
- From the command line

#### From the Windows or UNIX Menus

- 1 Open the figure window's **File** menu and select **Export**. This invokes the **Export** dialog box.



- 2 Use the **Save in** field to navigate to a directory in which you want to save your file.
- 3 Select a graphics format from the **Save as type** list.
- 4 Enter a filename in the **File name** field. An appropriate file extension, based on the format you chose, is already shown.
- 5 Click **Save** to export the figure.

### From the Command Line

From the command line, you must specify the graphics format as an option. See “Frequently Used Graphics Formats” on page 6-47. See the print reference page for a complete list of graphics formats and their corresponding option strings.

This example exports a figure to an EPS color file, `myfigure.eps`, in your current directory.

```
print -depsc myfigure
```

This example exports Figure No. 2 at a resolution of 300dpi to a 24-bit JPEG file, `myfigure.jpg`.

```
print -djpeg -f2 -r300 myfigure
```

This example exports a figure at screen size to a 24-bit TIFF file, `myfigure.tif`.

```
set(gcf, 'PaperPositionMode', 'auto') % Use screen size
print -dtiff myfigure
```

## Exporting a Figure in EPS Format with a TIFF Preview

Use the `print` command to export a figure in EPS format with a TIFF preview. When you import the figure, the application can display the TIFF preview in the source document. The preview is color if the exported figure is color, and black-and-white if the exported figure is black-and-white.

This example exports a figure to an EPS color format file, `myfigure.eps`, and includes a color TIFF preview.

```
print -depesc -tiff myfigure
```

This example exports a figure to an EPS black-and-white format file, `myfigure.eps`, and includes a black-and-white TIFF preview.

```
print -deps -tiff myfigure
```

## Exporting a Figure to the Clipboard

Export a figure to the clipboard in graphics-format when you want to paste it into another Windows application such as a word processor:

- From the Windows menus
- From the command line

### From the Windows Menus

This example exports a figure to the clipboard in Enhanced MetaFile (EMF) format. Figure settings are chosen that would make the exported figure suitable for use in a PowerPoint slide. Note that changing the settings modifies the figure displayed on the screen:

1 Create a figure containing text. You can use the following code.

```
x = -pi:0.01:pi;
[h] = plot(x, sin(x));
title('Sine Plot');
```

- 2 Select **Preferences** from the figure window's **File** menu. Then select **Figure Copy Template** from the **Preferences** dialog box.
- 3 In the **Figure Copy Template Preferences** panel, click the **PowerPoint** button. The MATLAB suggested settings for PowerPoint are added to the template.

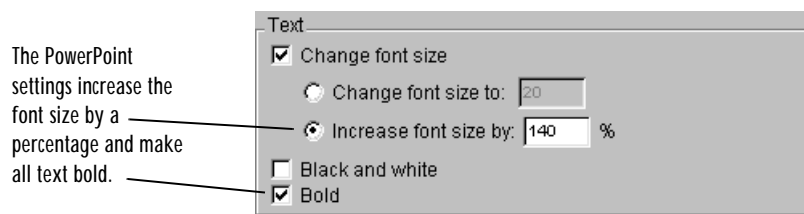

The Text Group Box after the PowerPoint button is clicked

- 4 In the **Lines** group box, change the **Custom width** to 4 points.
- 5 In the **Uicontrols and axes** group box, select **Keep axes limits and tick spacing** to prevent MATLAB from possibly rescaling ticks and limits when you export.
- 6 Click **Apply to Figure**. The changes appear in the figure window.
 

If you don't like the way your figure looks with the new settings, you can restore it to its original settings by clicking the **Restore** button.
- 7 In the left pane of the **Preferences** dialog box, expand the **Figure Copy Template** topic. Select **Copy Options**.
- 8 In the **Copy Options** pane, select **Metafile** to tell MATLAB to export the figure in EMF format.
- 9 Check that **Transparent background** is selected. This choice makes the figure background transparent and allows the slide background to frame the axes part of the figure.
- 10 Deselect **Match figure screen size** so that you can use your own figure size settings.
- 11 Click **OK**.

- 12 Select **Page Setup** from the figure window's **File** menu.
- 13 In the **Size and Position** tab, set **Width** to 10 and **Height** to 7.5. Make sure that **Units** are set to **Inches**.
- 14 Click **OK**.
- 15 Select **Copy Figure** from the **Edit** menu. Your figure is now exported to the clipboard and can be pasted into another Windows application such as a PowerPoint slide.

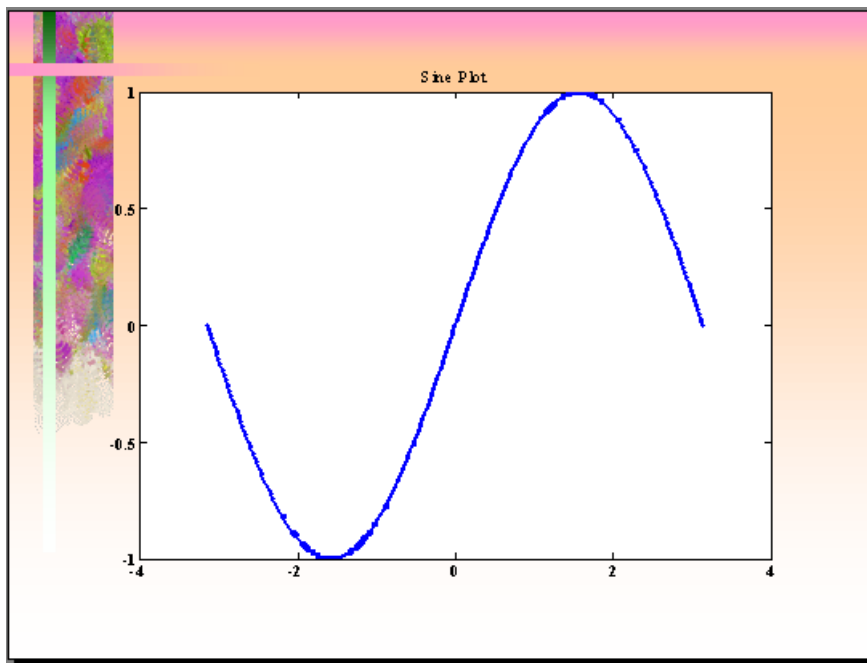

### From the Command Line

Use the print command and one of two clipboard formats (-dmeta, -dbitmap) to export a figure to the clipboard. Do *not* specify a filename.



This example exports a figure to the clipboard in Enhanced Metafile (EMF) format.

```
print -dmeta
```

This example exports a figure to the clipboard in Bitmap (BMP) 8-bit color format.

```
print -dbitmap
```

## Overview of Printing and Exporting

MATLAB enables you to print a figure from the screen directly to a printer, or to a file for later printing. It also enables you to export a figure in graphics format to a file, or to the clipboard, so that you can import, or paste, it into an application such as a word processor.

Before you print or export the figure, MATLAB enables you to change many settings that control the look of the figure. For example you can change the size and position of the figure, the paper type and orientation, as well as line, text and background attributes.

This section provides general information about:

- What elements of the figure are printed or exported
- How to select the figure to be printed or exported
- Basic ways to print or export a figure
- Default figure settings and how to change them

You can also find more advanced information on selecting the printer driver most appropriate for your use.

- Specifying a Printer Driver
- Types of Printer Drivers
- Choosing the Right Driver
- Drivers Provided by MATLAB

### What Is Printed or Exported

A printed or exported figure includes the area inside the figure window frame. The figure can include axis labels, uicontrols, and annotations.

### Which Figure Is Printed

By default, MATLAB prints the current figure. If you have more than one figure open, the current figure is the last active figure. Set the current figure:

- By giving the figure focus on your screen
- Using the command

```
print -ffigurehandle
```

For example, `print -f2` sets Figure No. 2 as the current figure. A figure's number is usually its handle.

## How to Print or Export

This is an overview of the ways you can print or export a figure in MATLAB. Subsequent sections of this chapter contain more detail.

Action	Ways to Print or Export a Figure
Print a figure to a printer or to a file.	<ul style="list-style-type: none"> <li>• Select <b>Print</b> from the figure window's <b>File</b> menu.</li> <li>• Use the print command</li> </ul>
Export a figure to a file in graphics format.	<ul style="list-style-type: none"> <li>• Select <b>Export</b> from the figure window's <b>File</b> menu.</li> <li>• Use the print command.</li> </ul>
Export a figure to the clipboard in graphics format.	<ul style="list-style-type: none"> <li>• Select <b>Copy Figure</b> from the figure window's <b>Edit</b> menu.</li> <li>• Use the print command.</li> </ul>

## Default Settings and How to Change Them

If you have not changed the default print and export settings, MATLAB prints or exports the figure:

- 8-by-6 inches with no window frame
- Centered on portrait format 8.5-by-11 inch paper if available
- Using white for the figure and axes background color
- With the ticks and limits of the axes scaled to accommodate the printed size

### Changing Settings for a Figure

In general, to change the property settings for a specific figure:

- In Windows, use the **Page Setup** dialog box, which you invoke by selecting **Page Setup** from the figure window's **File** menu, and the **Document Properties** dialog box which you invoke from the **Print** dialog box.
- In UNIX, use the **Page Setup** dialog box, which you invoke by selecting **Page Setup** from the figure window's **File** menu, and the **Options** dialog box, which you invoke from the **Print** dialog box.
- For exporting to the clipboard, use the **Figure Copy Template Preferences** and **Copy Options Preferences** panels. Invoke these panels from **Preferences** on the figure window's **File** menu.
- From the command line, use the `set` command.

The settings you change with the **Page Setup**, **Print**, and **Options** dialog boxes, and with the `set` command are saved with the figure and affect each print of the figure until you change the settings again.

The settings you change with the **Figure Copy Template Preferences** and **Copy Options Preferences** panels alter the figure as it displays on the screen. The **Figure Copy Template Preferences** panel enables you to restore the figure to its original state.

Some settings can also be changed for the current print operation by specifying options to the `print` command.

---

**Note** After you have changed the settings, preview the print image by selecting **Print Preview** from the figure window's **File** menu.

---

See “Changing the Figure's Settings” on page 6-30 for more information.

### Changing Session Defaults

MATLAB enables you to set the session defaults for figure properties. Set the session default for a property using the syntax

```
set(0, 'DefaultFigurePropertyName', 'value')
```

where *propertyName* is one of the named figure properties. This example sets the paper orientation for all subsequent print operations in the current MATLAB session.

```
set(0,'DefaultFigurePaperOrientation','landscape')
```

The Figure Properties reference page contains a complete list of the properties.

### Changing Session-to-Session Defaults

MATLAB enables you to set the session-to-session defaults for figure properties, the print device, and the print command. The print device can be either a printer or a graphics format in which figures are exported.

**Print Device and Print Command.** Set the default print device and the default print command in your `printopt.m` file. This file contains instructions for changing these settings and for displaying the current defaults. Open `printopt.m` in your editor by typing the command

```
edit printopt
```

Scroll down about 40 lines until you come to this comment line and make your changes after this line.

```
%--> Put your own changes to the defaults here (if needed)
```

**Figure Properties.** Set the session-to-session default for a property by including this command in your `startup.m` file.

```
set(0,'DefaultFigurepropertyname','value')
```

where *propertyname* is one of the named figure properties. For example,

```
set(0,'DefaultFigureInvertHardcopy','off')
```

keeps the figure background in the screen color.

This is the same command you use to change a session default, except that it executes automatically every time MATLAB is invoked. The Figure Properties reference page contains a complete list of the properties.

**Colored Lines and Text.** In Windows, you can set the session-to-session default for how colored lines and text are sent to the printer in the **Figure window printing** box on the **General Preferences** panel. You can override this default setting for a specific figure from the **Lines and Text** tab on the figure's **Page Setup** dialog box.

### Printing a Figure to a Printer or a File

You can print a figure using the menus, or from the command line. You can print it directly to a printer, or to a file for later printing.

---

**Note** If you print a figure to a file, the file can only be printed and cannot be imported into another application. If you want to create a figure file that you can import into an application, see “Exporting a Figure in Graphics Format” on page 6-47.

---

This section introduces:

- The dialog boxes you use to print a figure
- The commands you use to print a figure from the command line or from a program

It also tells you how to:

- Change the settings that control the way a figure looks when you print it.
- Print the figure.

### Using Print Dialog Boxes

Invoke the dialog boxes you need to print the figure from the **File** menu on the figure window:

- 1 Use the **Page Setup** dialog box to make any settings needed for printing, such as the size of the printed figure.
- 2 Use the **Print Preview** dialog box to preview your printed figure.
- 3 Use the Windows or UNIX **Print** dialog box to send the figure to the printer.

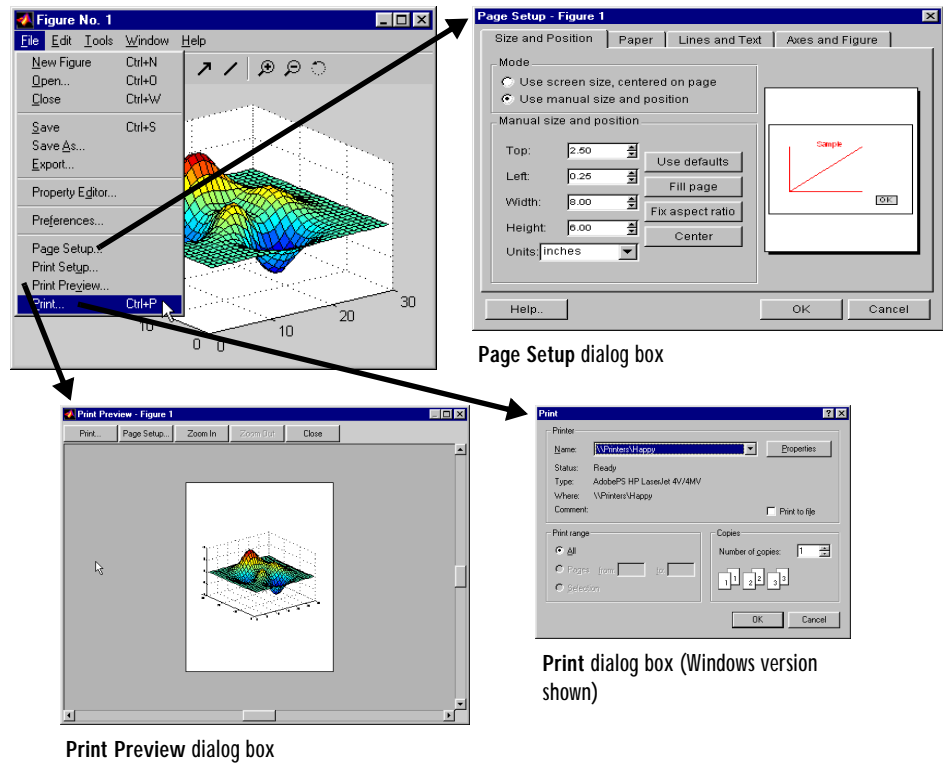

For detailed help on any dialog box element, click the **Help** button on the element to see its context-sensitive help.

**Note** You can invoke the **Print**, **Page Setup**, and **Print Preview** dialog boxes from a program or from the command line with the `printdlg`, `pagesetupdlg`, and `printpreview` commands.

## From the Command Line

You can print a MATLAB figure from the command line or from a program. Use the `set` function to set the properties that control how the printed figure looks. Use the `print` command to print it to a printer or to a file.

### The set Function

The set function changes the values of properties that control the look of a printed figure. These properties are stored with the figure. When you change one of the properties, the new value is saved with the figure and affects each print of the figure until you change the setting again.

To change the print properties of the current figure, the set command has the form

```
set(gcf, 'Property1', value1, 'Property2', value2, ...)
```

where `gcf` is a call that gets the handle of the current figure, and each property-value pair consists of a named property followed by the value to which the property is set. For example,

```
set(gcf, 'PaperUnits', 'centimeters', 'PaperType', 'A4', ...)
```

sets the units of measure and the paper size. “Changing the Figure’s Settings” on page 6-30 describes commonly used print properties. The Figure Properties reference page contains a complete list of the properties.

You can also use the `get` command to retrieve the value of a specific property.

```
a = get(gcf, 'Property')
```

---

**Note** See “Changing Session Defaults” on page 6-24 and “Changing Session-to-Session Defaults” on page 6-25 for more information about managing default property values.

---

### The print Command

The print command sends the figure to a printer, saves it to a file, exports it to a graphics-format file, or exports it to the clipboard.

The command and function forms of `print` differ slightly in their syntax. Although this document uses the command form, you can easily use the equivalent function form in a program. In both forms, all arguments are optional and can be placed in any order.

The command form of `print` is

```
print -device -options filename
```



The function form of print is

```
print('-device', '-options', 'filename')
```

where:

- device      For printing, -device is a printer.  
For exporting, -device is the graphics format in which the figure is exported.
- options     Controls some aspects of the look of the printed figure. It can also control the action to be taken, or specify the figure to be printed or exported.
- filename     Is the name of the file to which the figure is saved, appended, or exported.

---

**Note** See “Printing the Figure” on page 6-41 for information about specific -device and -options values.

---

You control what action the print command takes, depending on the presence or absence of certain arguments. This table describes what arguments to use. The table assumes factory defaults.

Action	Print Command Arguments
Print a figure to a printer.	Don't specify a filename, and specify a printer.
Print a figure to a file for later printing.	Specify a filename, and specify a printer.

Action	Print Command Arguments
Export a figure to a graphics format file that you can later import into an application.	Specify a filename, and specify a graphics format.
Export a figure in graphics format to the clipboard.	Don't specify a filename, and specify a graphics format.

---

**Note** If you specify no device in the print command, MATLAB uses the default device for your platform from `printop.m`. If you have not modified `printop.m`, the default device is a printer and MATLAB prints the figure. If the default driver is modified to be a graphics format, MATLAB exports the figure.

---

## Changing the Figure's Settings

This section tells you how to use the **Page Setup** dialog box or the command line to change:

- The size of the figure
- The position of the figure on the page
- Units of measure
- The paper size and type
- Color attributes of lines, text, and background
- Axes, tick marks, and uicontrols
- Rendering the figure

Using the **Printing Options** or **Document Properties** dialog boxes, or the command line, you can also control these settings:

- Figure resolution
- Uncropped output
- Use of CMYK color space

---

**Note** See “Using Print Dialog Boxes” on page 6-26 for an overview of the dialog boxes, and “From the Command Line” on page 6-27 for information about the commands and functions you use to change the print settings.

---

### Examples

These examples show you how to change specific settings from the Windows and the UNIX menus, and from the command line:

- “Printing to a Printer at Screen Size” on page 6-6
- “Printing to a Printer, Locking the Ticks and Limits of the Axes” on page 6-7
- “Printing to a Printer, Setting the Paper Size” on page 6-8
- “Printing to a Printer, Setting the Size of and Centering a Figure” on page 6-9

### Size of the Figure

These properties control the size of the printed figure on the page. In some cases, they also control the position. See “Position of the Figure on the Page” on page 6-34 for properties that control position.

---

**Note** It is often easier to see what the printed or exported figure will look like, if you change the size of the screen figure by clicking and dragging its borders, then printing it at screen size.

---

Action	Page Setup Dialog Box	Command Line
Print figure at 8-by-6 inches	<p><b>Size and Position</b> tab. Set the <b>Mode</b> to <b>Use manual size and position</b>. MATLAB prints the figure at 8-by-6 inches and centers it on the page (if you have not changed the default).</p> <p><b>Note:</b> You can also make this change from the UNIX <b>Print</b> dialog box.</p>	Set PaperPositionMode property to 'manual'. This is the default.
Print figure at screen size	<p><b>Size and Position</b> tab. Set the <b>Mode</b> to <b>Use screen size, centered on page</b>. MATLAB prints the figure the same size it is on the screen. If you select this option, you cannot change the <b>Top, Left, Width</b> and <b>Height</b> fields. However, they are updated to show the position and screen size of the figure.</p> <p><b>Note:</b> You can also make this change from the UNIX <b>Print</b> dialog box.</p>	Set PaperPositionMode property to 'auto'.
Set the height and width of the figure	<p><b>Size and Position</b> tab. Set the <b>Width</b> and <b>Height</b> fields to the desired size of the figure. MATLAB prints the figure with these dimensions. The <b>Width</b> and <b>Height</b> fields are initially set to 8.00 and 6.00 inches respectively.</p> <p><b>Mode</b> must be set to <b>Use manual size and position</b>.</p>	Set PaperPosition property to a 4-element vector [leftmargin, bottommargin, width, height].
<p><b>Note</b> Alternatively, you can change the size of the screen figure by clicking and dragging its borders, then printing it at screen size.</p>		

Action	Page Setup Dialog Box	Command Line
Size the figure interactively	<p>Set the size of the printed figure by dragging the figure boundaries in the preview image on the right side of the dialog box. The <b>Width</b> and <b>Height</b> fields are updated to show the print size of the figure.</p> <p><b>Mode</b> must be set to <b>Use manual size and position</b>.</p>	Not available
Fill the page	<p><b>Size and Position</b> tab. Click on <b>Fill page</b>. MATLAB prints the figure to fill the page, with a margin of 0.25 inches on all four sides. The <b>Width</b> and <b>Height</b> fields are updated to show the print size of the figure.</p> <p><b>Mode</b> must be set to <b>Use manual size and position</b>.</p>	<p>Set PaperPosition property to a 4-element vector [leftmargin, bottommargin, width, height].</p> <p>Use the value of the PaperSize property ([width, height]) to calculate desired figure size.</p>
Fix the aspect ratio	<p><b>Size and Position</b> tab. Click on <b>Fix aspect ratio</b>. MATLAB resizes the printed figure to have the same aspect ratio as the screen figure. The aspect ratio is equal to the width divided by the height. The <b>Width</b> and <b>Height</b> fields are updated to show the new print size of the figure.</p> <p><b>Mode</b> must be set to <b>Use manual size and position</b>.</p>	<p>Set PaperPosition property to a 4-element vector [leftmargin, bottommargin, width, height].</p> <p>Get the figure's Position property ([leftscreenmargin, bottomscreenmargin, width, height]) to calculate the aspect ratio of the screen figure window.</p>

### Position of the Figure on the Page

These properties control the position of the printed figure on the page.

Action	Page Setup Dialog Box	Command Line
Set the figure margins	<p><b>Size and Position</b> tab. Set the <b>Top</b> and <b>Left</b> fields to the size of the desired margins. MATLAB positions the figure using these margins. The <b>Top</b> and <b>Left</b> fields are initially set to 2.50 and .25 inches respectively.</p> <p><b>Mode</b> must be set to <b>Use manual size and position</b>.</p>	<p>Set PaperPosition property to a 4-element vector [leftmargin, bottommargin, width, height].</p> <p><b>Note:</b> PaperPosition sets the <i>bottom</i> margin, rather than the <i>top</i> margin.</p>
Center the figure	<p><b>Size and Position</b> tab. Click on <b>Center</b>. MATLAB centers the figure horizontally and vertically on the page.</p> <p><b>Mode</b> must be set to <b>Use manual size and position</b>.</p>	<p>Set PaperPosition property to a 4-element vector [leftmargin, bottommargin, width, height].</p> <p>Get the PaperSize property ([paperwidth, paperheight]) to calculate desired margins.</p>
Position the figure interactively	<p>Position the printed figure by dragging the figure in the preview image on the right side of the dialog box. The <b>Top</b> and <b>Left</b> fields are updated to show the new margins.</p> <p><b>Mode</b> must be set to <b>Use manual size and position</b>.</p>	Not available

## Units of Measure

This property controls the units in which all values that describe the size and position of the printed figure are shown on the dialog boxes or returned on the command line.

Action	Page Setup Dialog Box	Command Line
Set the units of measure	<p><b>Size and Position</b> and <b>Paper</b> tabs. Select the desired units from the list under <b>Units</b>. The <b>Top</b>, <b>Left</b>, <b>Width</b> and <b>Height</b> fields in the Size and Position tab are automatically converted to the selected units.</p> <p><b>Mode</b> must be set to <b>Use manual size and position</b>.</p> <p>Inches, centimeters, and points are absolute units. (One point equals 1/72 of an inch.) Normalized units are relative to the paper size, namely, they map the lower-left corner of the figure to (0,0) and the upper-right corner to (1.0, 1.0).</p>	<p>Set the PaperUnits property. Possible values are 'inches', 'centimeters', 'points', and 'normalized'. The default is 'inches'.</p> <p>This setting applies to all values you set or get using the PaperPosition property.</p>

## Paper Size and Type

These properties enable you to select by type or by size, the paper on which the figure is printed.

Action	Page Setup Dialog Box	Command Line
Set the paper type	<p><b>Paper</b> tab. Use the list under <b>Paper size</b> to select from a list of predefined “paper types.” The paper <b>Width</b> and <b>Height</b> fields are updated automatically to reflect the dimensions for your chosen paper type.</p> <p>If you are a Windows user, the list shows the paper types supported by the current printer. If you are a UNIX user, the list shows MATLAB's built-in paper types. By default, MATLAB selects portrait format 8.5-by-11.0 inch paper, if available.</p>	<p>Set the PaperType property. Some possible values are 'usletter' (8.5-by-11 inches), 'uslegal' (11-by-14 inches), 'tabloid' (11-by-17 inches), 'A4' (210-by-297 mm).</p> <p>See the Figure Properties reference page for a list of paper types.</p>
Set the paper width and height	<p><b>Paper</b> tab. Set the <b>Width</b> and <b>Height</b> fields to the desired paper width and height if you cannot find a suitable paper type in the <b>Paper size</b> list. <b>Paper size</b> is automatically updated to show a paper type of &lt;custom&gt;. When the paper type is set to &lt;custom&gt;, the paper size is handled by the printer.</p>	<p>Set PaperSize property to a 2-element vector [paperwidth, paperheight].</p>



Action	Page Setup Dialog Box	Command Line
Set the paper orientation	<p><b>Paper</b> tab. Click on one of the <b>Orientation</b> option buttons:</p> <p><b>Portrait</b> - Specifies that the longer paper dimension is oriented vertically with respect to the figure.</p> <p><b>Landscape</b> - Orients the longer paper dimension horizontally.</p> <p><b>Rotated</b> -Equivalent to rotating the paper 180° from landscape orientation. If <b>Rotated</b> is not supported by the current printer, the figure prints with landscape orientation.</p>	<p>Set the PaperOrientation property. Possible values are 'portrait', 'landscape', and 'rotated'. The default is 'portrait'.</p> <p>You can use the orient function if you want the figure centered on the paper.</p>

### Attributes of Lines, Text, and Background

By default, MATLAB forces the figure background to white, but retains colors used in the figure. These properties enable you to override this default behavior.

Action	Page Setup Dialog Box	Command Line
Force line and text objects to black and white	<b>Lines and Text</b> tab. Click on the <b>Black and white</b> option in the <b>Lines and Text</b> tab. The lines and text are printed all black or all white, depending on the background color. This setting is recommended for use with black and white printers because colored lines and text are dithered to gray that may not be suitable for thin lines and text characters.	Specify the device as a black-and-white printer or graphics format. See the print reference page for a list of printers (i.e., drivers) and graphics formats.
Keep the screen color for lines and text	<b>Lines and Text</b> tab. Click on the <b>Color (don't convert)</b> option in the <b>Lines and Text</b> tab. The text and solid colored lines are printed in the same color as they are on the screen. If you are using a black and white printer, all of your text and solid colored lines are converted to shades of gray.	This is the default.
Force the figure background to white	<b>Axes and Figure</b> tab. Click on the <b>Force white background</b> option in the <b>Axes and Figure</b> tab. MATLAB prints the figure with white axes and figure backgrounds. This setting is intended to save on toner and may produce better-looking printed results.	Set the <code>InvertHardCopy</code> property to 'on'. This is the default.
Keep the figure background in the screen color	<b>Axes and Figure</b> tab. Click on the <b>Keep screen background color</b> option in the <b>Axes and Figure</b> tab. MATLAB prints the figure using the screen colors for both the axes and figure backgrounds. If you select this option and use a black and white printer, the background colors are dithered to shades of gray.	Set the <code>InvertHardCopy</code> property to 'off'.

If you have a black and white printer, you may want to read [Getting the Best Results with Black-and-White Printers](#).

### Axes, Tick Marks, and Uicontrols

By default, MATLAB recomputes the tick marks and the axes limits based on the size of the printed figure. It also retains uicontrols in the figure. These properties enable you to override this default behavior.

Action	Page Setup Dialog Box	Command Line
Recompute axes limits and ticks	<p><b>Axes and Figure</b> tab. Click on the <b>Recompute axes limits and ticks</b> option. MATLAB scales the number and placement of tick marks and the limit values of the axes depending on the size of the printed figure.</p> <p><b>Note:</b> You can also make this change in the UNIX <b>Print</b> dialog box.</p>	Set the <code>XTickMode</code> , <code>YTickMode</code> , and <code>ZTickMode</code> properties to 'auto'. This is the default.
Keep screen limits and ticks	<p><b>Axes and Figure</b> tab. Click on the <b>Keep screen limits and ticks</b> option. MATLAB keeps the same number of ticks and the same limit values in the printed figure as are in the screen figure.</p> <p><b>Note:</b> You can also make this change in the UNIX <b>Print</b> dialog box.</p>	Set the <code>XTickMode</code> , <code>YTickMode</code> , and <code>ZTickMode</code> properties to 'manual'.
Keep or suppress printing of UI controls	<p><b>Axes and Figure</b> tab. Deselect <b>Print UIControls</b> if you do not want uicontrols to appear in the printed figure. If you leave this check box selected, any uicontrols in the figure appear in the printout.</p> <p>Uicontrols include push buttons, listboxes, sliders, pop-up menus, editable text boxes, and check boxes that you can add to a figure. See the <code>uicontrol</code> reference page for a complete list.</p>	Use <code>print -noui</code> to suppress the uicontrols. The default is to keep the uicontrols.

### Rendering the Figure

A renderer is software and/or hardware that draws the figure you see on the screen in a file, or formats it for a printer. By default, MATLAB chooses a renderer.

Action	Page Setup Dialog Box	Command Line
Let MATLAB choose the renderer	<p><b>Axes and Figure</b> tab. Select <b>Default (auto mode)</b> in the <b>Figure renderer</b> list. MATLAB selects a rendering method based on the complexity of the figure and the settings of various Handle Graphics properties. This setting usually produces a satisfactory printout.</p> <p>See the <a href="#">Figure Properties reference page</a> for information about MATLAB's autoselection criteria.</p>	This is the default.
Select a specific renderer	<p><b>Axes and Figure</b> tab. MATLAB uses the renderer you select from the <b>Figure renderer</b> list to render the figure. Select <b>Painter's</b> if you want to print using vector graphics. Select <b>Z-buffer</b> or <b>OpenGL</b> if you want to print using raster (bitmap) graphics.</p>	Set the <b>Renderer</b> property to 'painters', 'zbuffer', or 'OpenGL'.

---

**Note** For printing, the renderer selected using **Page Setup** takes precedence over any renderer selection done in the command line. However, when the renderer is set to **Default (auto mode)** in **Page Setup**, you may set your printing renderer with the command line.

---



---

**Note** The renderer you can use is sometimes limited by the printer driver or export format. See the table of renderer support.

---

For more information on setting the rendering method, see

- [Comparing Rendering Methods](#)

- The Default Renderer for MATLAB
- Reasons for Changing the Renderer

## Printing the Figure

After you have changed the settings to make your printed figure look the way you want, you are ready to print the figure. This section tells you how to print your figure to a printer or to a file using:

- The Windows **Print** dialog box
- The UNIX **Print** dialog box
- The command line

---

**Note** Before printing the figure, preview the print image by selecting **Print Preview** from the figure window's **File** menu. Use the **Page Setup** dialog box or the `set` command to adjust the look of the exported figure. See “Changing the Figure's Settings” on page 6-30 for details.

---

### From the Windows Print Dialog Box

MATLAB for Windows uses the standard Windows **Print** dialog box, which normally comes with Windows software products. It enables you to:

- Choose the printer to which the figure is printed.
- Specify the number of copies to print.
- Choose to print the figure to a file for later printing.

Select **Print** from the figure window's **File** menu to invoke the **Print** dialog box. For examples, see “Printing to a Printer” on page 6-3 and “Printing to a File” on page 6-3.

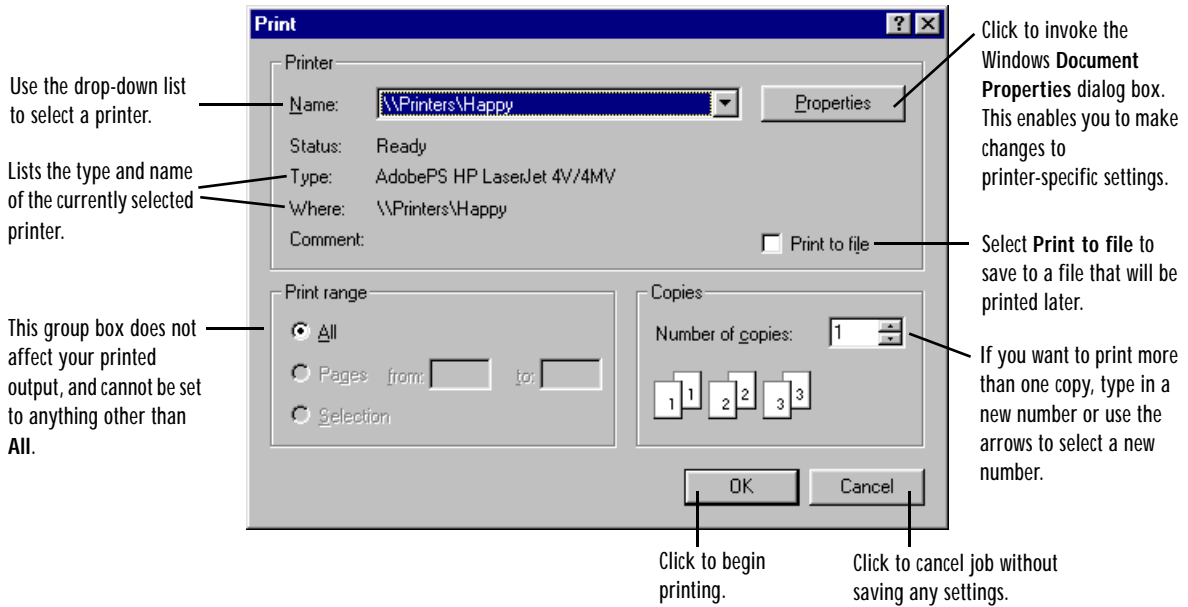

### From the UNIX Print Dialog Box

MATLAB for UNIX has a **Print** dialog box and an associated **Printing Options** dialog box.

**Print Dialog Box.** The **Print** dialog box enables you to:

- Choose the printer to which a figure is printed.
- Print the figure to a file for later printing.
- Choose the driver that controls the printed figure's format.
- Preserve the same axis and tick marks you have in your displayed figure window. By default, MATLAB scales the number and placement of tick marks and the axes limits based on the size of the printed figure.
- Print the figure at screen size instead of the default 8-by-6 inches
- Invoke the **Printing Options** dialog box

Select **Print** from the figure window's **File** menu to invoke the **Print** dialog box. For examples, see "Printing to a Printer" on page 6-3 and "Printing to a File" on page 6-3.

Use the drop-down list to select a printer.

Select **Printer** to print now or select **File** to save to a file that can be printed later

Type in a name if you are printing to a file.

Use the drop-down list to select a printer driver.

Click **Same size as screen** if you want the printed plot to have the same size as it does on your screen.  
Click **8 by 6 inches** if you want the printed output to have these dimensions.

Click to invoke help for this dialog box.

Click **Same as on screen** to force MATLAB to print the same number of ticks and the same limit values for the axes as are used on the screen.  
Click **Allow MATLAB to select** to let MATLAB scale the limits and ticks of the axes based on the size of the printed figure.

Click to begin printing.

Click to cancel job without saving any settings made.

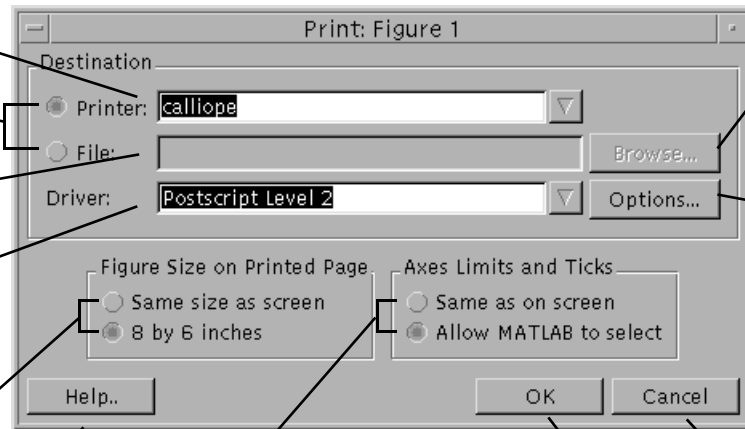

Click to browse to a directory to save your file in when printing to a file.

Invokes the **Printing Options** dialog box.

**Printing Options Dialog Box.** The **Printing Options** dialog box enables you to set some print settings just before printing, such as the rendering method to use, or the resolution of the printed figure, in dots per inch. See "Rendering the Figure" on page 6-40 for information about rendering.

Click the **Options** button on the **Print** dialog box to invoke the **Printing Options** dialog box.

Check to leave a little space between the outermost objects in the plot and the edges of the plot's background.

Check to produce output in CMYK instead of RGB. This is for postscript printers and drivers only.

Check to have MATLAB use the default PostScript character set. This is useful for early PostScript printers that do not support the PostScript operator ISOLatin1Encoding.

Check to prevent user interface (UI) controls (that you added to the plot) from appearing in the printed plot.

Click here to have MATLAB choose a resolution that is supported by the chosen printer driver and makes sense for the type of renderer selected.

Or, click here to set the resolution for the printout to the resolution used by the screen.

Or, click here and then enter a resolution value in the text box. The text box is grayed out if Specify resolution in dots per inch is not selected.

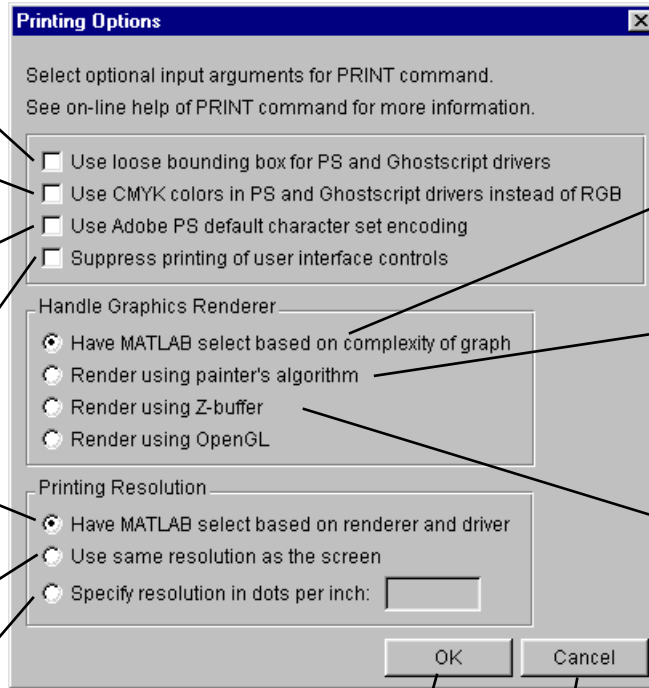

Click here to have MATLAB choose the renderer.

Or, click here to use the Painter's algorithm, which creates a metafile.

Or, click here to use the Z-buffer algorithm, which creates a bitmap.

Click to apply these print settings to the current plot.

Click to dismiss dialog box without saving any settings made.

### From the Command Line

Use the print command to print the figure to a printer or to a file.

```
print -device -options filename
```

where the command arguments are:

-device      A printer, such as a Hewlett-Packard DeskJet 500. Some commonly used printers and their device specifiers are:

Canon BubbleJet BJ200 color      -dbj200



Canon BubbleJet BJ600/4000/70 color	-dbj600
Epson and compatible 9- or 24-pin dot matrix printers	-depson
HP DeskJet 500	-ddjet500
HP LaserJet III	-dljet3
PostScript Level 2 black and white	-dps2
Postscript Level 2 color	-dpsc2

If you do not specify a printer, MATLAB uses the default device specified in `printop.m` for your platform. See the `print` reference page for a list of supported printers (i.e., drivers).

`-options` Specifies options that control some aspects of the look of the printed figure. It can also control the action to be taken, or specify the figure to be printed or exported. Unlike the properties you set with the `set` function, these values are not saved with the figure. You must specify them each time you print the figure.

Commonly used options are:

<code>-append</code>	Append the figure to an existing PostScript file. PostScript only.
<code>-fhandle</code>	Handle of the figure to print. For Figure No. 2, specify <code>-f2</code> . By default MATLAB prints the last active figure.
<code>-noui</code>	Suppress printing of uicontrols.
<code>-Pprinter</code>	Printer to which the figure is printed. UNIX only.

*-rnumber* Resolution in dots per inch.

See the print reference page for a list of supported options.

*filename* Specifies the name of the file to which the figure is printed or appended for later printing. If you do not specify a filename, the figure is printed to a printer.

If you are printing a figure to a new file and do not specify a file extension, `print` appends an extension that is appropriate for the device.

## Exporting a Figure in Graphics Format

Export a figure in a graphics format to a file if you want to import it into another application, such as a word processor. You can also export it to the Windows clipboard, and paste it from there into an application. Before deciding on a graphics format, check what formats are supported by your target application and platform. See the print reference page for a complete list of supported graphics formats.

### Frequently Used Graphics Formats

Format	Description	Command Line -device Parameter
BMP 8-bit color bitmap	Export a figure to the clipboard (Windows only).	-dbitmap
EMF color vector format	Export a figure to the clipboard (Windows only).	-dmeta
EPS color and black-and-white	Export line plots or simple graphs to a file. <b>Note.</b> An EPS file does not display within some applications unless you add a TIFF preview image to it. See the example “Exporting a Figure in EPS Format with a TIFF Preview” on page 6-18.	-deps (black and white) -depsec (color) -depsec -tiff (TIFF preview)
JPEG 24-bit	Export plots with surface lighting or transparency to a file. This format can be displayed by most Web browsers.	-djpeg  -djpegnumber where <i>number</i> is the compression.
TIFF 24-bit bitmap color	Export plots with surface lighting or transparency to a file. Widely available. A good format to choose if you are not sure what formats your application supports.	-dtiff

### Examples

These examples show you how to export a figure to a file using a specific graphics format, and to the clipboard:

- “Exporting a Figure to a File in a Specific Graphics Format” on page 6-16
- “Exporting a Figure in EPS Format with a TIFF Preview” on page 6-18
- “Exporting a Figure to the Clipboard” on page 6-18

### More Information on Exporting

For further information on file formats and how to select the best one for your application, see

- Details About Selected File Formats
- How to Choose a File Format
- Built-in MATLAB and Ghostscript Formats
- Bitmap and Vector Formats
- Getting the Best Results With Bitmap Formats
- Preserving Colors in Exported Figures

Other topics related to exporting are:

- Using the `getframe` Command to Export a Graphic
- Importing MATLAB Graphics Into Other Applications

### Exporting to a File

You can export a figure to a file in a specific graphics format from the Windows or UNIX **Export** dialog box or from the command line.

---

**Note** Before you export the figure, preview the image to be exported by selecting **Print Preview** from the figure window’s **File** menu. Use the **Page Setup** dialog box or the `set` command to adjust the look of the exported figure. See “Changing the Figure’s Settings” on page 6-30 for details.

---

### From the Windows or UNIX Export Dialog Box

Use the **Export** dialog box to select a file format, specify a filename, and navigate to a directory in which you want to save your file. To invoke the **Export** dialog box, select **Export** from the figure's **File** menu.

See "Frequently Used Graphics Formats" on page 6-47.

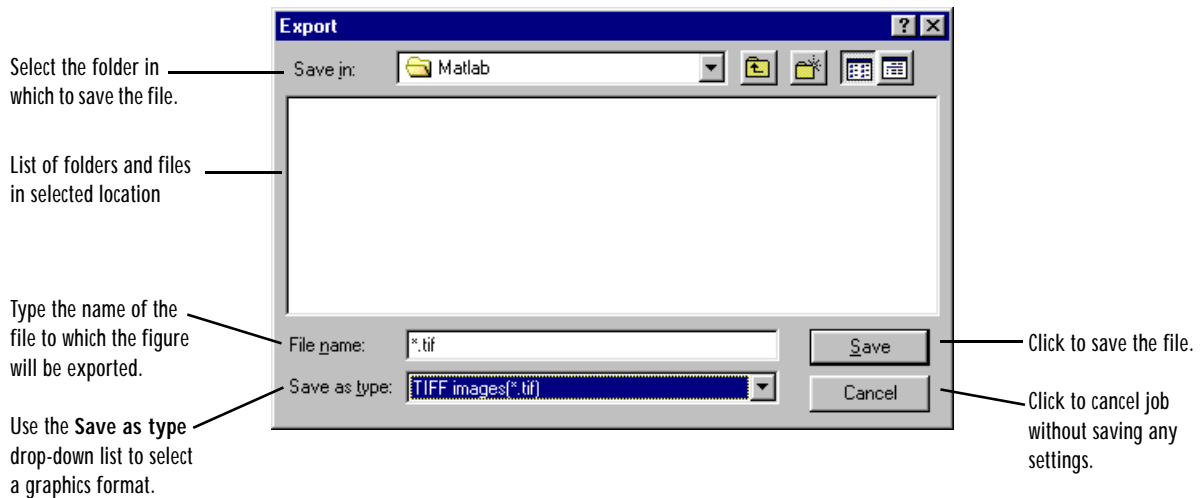

### From the Command Line

Use the `print` command to export the figure in graphics format.

```
print -device -options filename
```

where the command arguments are:

- device      The graphics format, such as EPS color or JPEG 24-bit, used to draw the figure in the file. See “Frequently Used Graphics Formats” on page 6-47. See the print reference page for a complete list of supported graphics formats.
- options    Specifies options that control some aspects of the look of the exported figure. You can also specify the figure to be exported. Unlike the properties you set with the `set` function, these values are not saved with the figure. You must specify them each time you export the figure. Commonly used options are:
  - handle*    Handle of the figure to export. For Figure No. 2, specify `-f2`. The default is the current figure.
  - noui*       Suppress printing of uicontrols.
  - rnumber*   Resolution in dots per inch.See the print reference page for a complete list of supported options.
- filename    Specifies the name of the file to which the figure is exported. If you do not specify a file extension, `print` appends an extension that is appropriate for the graphics-format.

## Exporting to the Clipboard

You can export a figure in graphics format to the Windows clipboard from the figure’s Edit menu or from the command line. You can choose one of two graphics formats for exporting to the clipboard, EMF color vector (`-dmeta`) or BMP 8-bit color bitmap (`-dbitmap`). If you use the menus to export the figure, you can also elect to let MATLAB choose which of the two formats to use.

By default, the format is chosen based on the rendering method used to display the figure. If the figure is displayed with the OpenGL or Z-buffer renderer, Windows Bitmap is the default. If the figure is displayed with the Painter’s renderer, the EMF format is used.

---

**Note** Many property settings you make with the **Page Setup** dialog box or the set command apply to both printed and exported figures. For exported figures, the settings that affect the position of the figure on the page, or the size and orientation of the paper, are ignored. See “Changing the Figure’s Settings” on page 6-30 if you want to change any of the settings.

---

### From the Edit Menu

To export the current figure to the clipboard, select **Copy Figure** from the figure window’s **Edit** menu.

Before you export the figure, you can use the **Figure Copy Template Preferences** panel and the **Copy Options Preferences** panel to adjust the figure’s settings. These settings override corresponding settings you made using the **Page Setup** dialog box or the set command. Invoke the **Preferences** panels from the figure’s **File** menu.

**Figure Copy Template Preferences.** This panel enables you to create a template and apply it to the current figure. When you click **Apply to Figure**, MATLAB saves the template and uses it to modify the screen figure. Click **Restore Figure** to restore the figure to its original state.

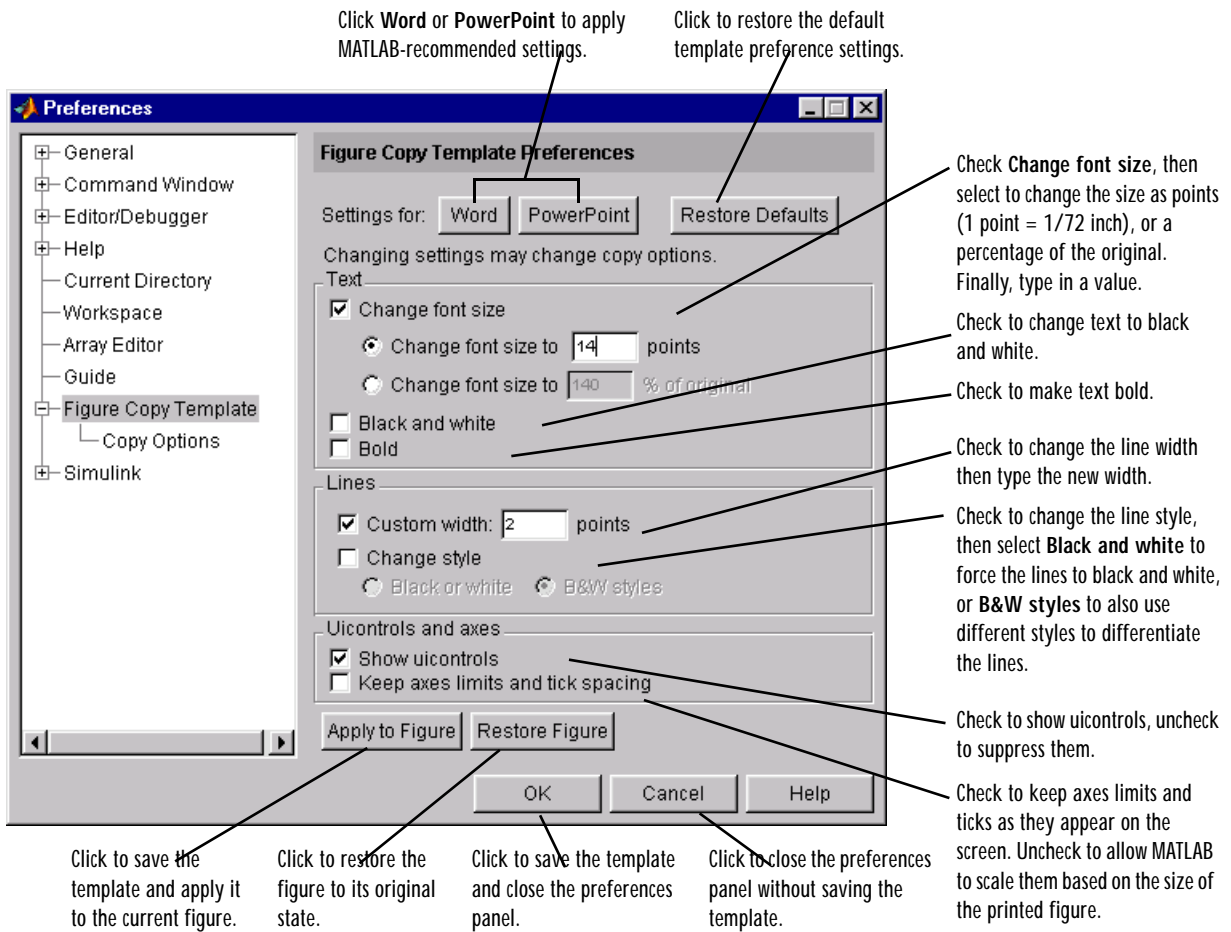

**Copy Options Preferences.** This panel enables you to adjust the figure's settings. These changes override settings you made with the **Page Setup** dialog box or the **set** command. They do not affect the way the figure looks on the screen.



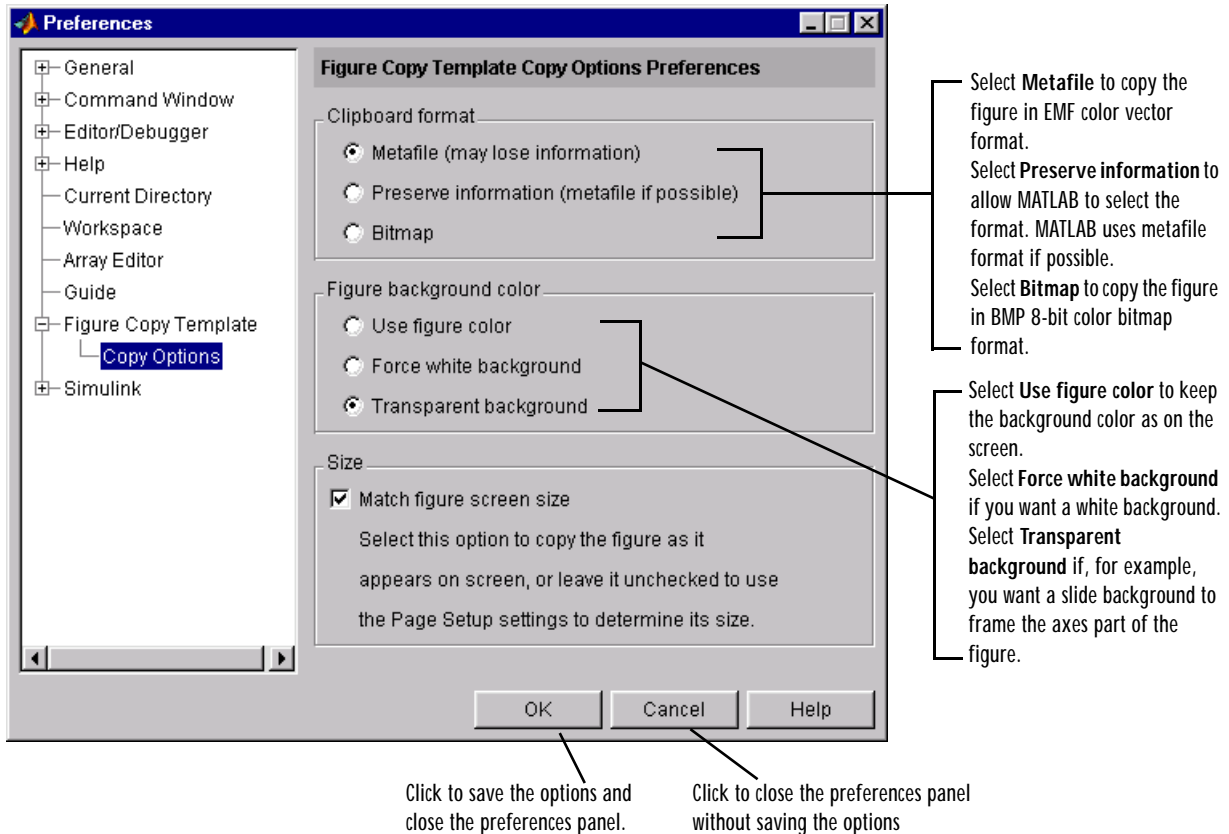

---

**Note** See “Exporting a Figure to the Clipboard” on page 6-18.

---

### From the Command Line

Use the print command to export the figure to the clipboard in graphics format. Do *not* specify a filename.

```
print -device -options
```

where the command arguments are:

- device      Graphics format used to draw the figure on the clipboard:
    - dmeta      EMF color vector format
    - dbitmap    BMP 8-bit color bitmab
  - options    Specifies options that control some aspects of the look of the exported figure. You can also specify the figure to be exported. Unlike the properties you set with the `set` function, these values are not saved with the figure. You must specify them each time you export the figure. Commonly used options are:
    - handle*    Handle of the figure to export. For Figure No. 2, specify `-f2`. By default MATLAB exports the last active figure.
    - noui*      Suppress printing of uicontrols.
- See the print reference page for a complete list of supported options.

## Troubleshooting

This section lists some common problems you might encounter when printing or exporting your figure. Refer to the appropriate section listed below.

- **Printing Problems**

- “Printer Drivers” on page 6-56
- “Default Settings” on page 6-57
- “Printing Lines” on page 6-57
- “Printer” on page 6-58
- “Rotated Text” on page 6-59
- “ResizeFcn Warning” on page 6-59

- **Exporting Problems**

- “Background Color” on page 6-59
- “Default Settings” on page 6-59
- “Microsoft Word” on page 6-60
- “File Format” on page 6-61
- “Size of Exported File” on page 6-61
- “Making Movies” on page 6-62
- “Extended Operations” on page 6-62

- **General Problems**

- “Background Color” on page 6-63
- “Default Settings” on page 6-63
- “Dimensions of Output” on page 6-63
- “Axis and Tick Labels” on page 6-64
- “UI Controls” on page 6-64
- “Cropping” on page 6-65
- “Text Object Font” on page 6-65

If you don't find your problem listed here, try searching the Knowledge Base maintained by the MathWorks Technical Support Department. Go to <http://www.mathworks.com/support> and enter a topic in the search field.

## Printing Problems

### Printer Drivers

I'm using a Windows printer driver and have been encountering problems such as segmentation violations, general protection faults, application errors, and unexpected output.

Try one of the following solutions:

- Check the table of drivers in the print reference page to see if there are other drivers you can try.
  - If your printer is PostScript compatible, try printing with one of MATLAB's built-in PostScript drivers.
  - If your printer is not PostScript compatible, see if one of MATLAB's built-in Ghostscript devices is appropriate for your printer model. These devices use Ghostscript to convert PostScript files into other formats, such as HP LaserJet and Canon BubbleJet.
- Contact the printer vendor to obtain a different native printer driver. The behavior you are experiencing may occur only with certain versions of the native printer driver. If this doesn't help and you are using Windows, try reinstalling the drivers that were shipped with your Windows installation disk.
- Export the figure to a graphics-format file and then import it into another application before printing it. For information about exporting figures with MATLAB, see "Exporting".

When I use the `print` command with the `-deps` switch, I receive this error message.

```
Encapsulated PostScript files cannot be sent to the printer.  
File saved to disk under name 'figure2.eps'
```

As the error message indicates, your figure was saved to a file. EPS is a graphics file format and cannot be sent to a printer using a printer driver. To send your figure directly to a printer, try using one of the PostScript driver switches. See the table of drivers in the print reference page. To print an EPS file, you must first import it into a word processor or other software program.

## Default Settings

My printer uses a different default paper type than MATLAB's default type of "letter." How can I change the default paper type so that I won't have to set it for each new figure?

You can set the default value for any property by adding a line to `startup.m`. Adding the following line sets the default paper type to A4.

```
set(0, 'DefaultFigurePaperType', 'A4');
```

In your call to `set`, combine the word `Default` with the name of the object `Figure` and the property name `PaperType`.

I set the paper orientation to landscape, but each time I go to print a new figure, the orientation setting is portrait again. How can I change the default orientation so that I won't have to set it for each new figure?

See the explanation for the question above. Adding the following line to `startup.m` sets the default paper orientation to landscape.

```
set(0, 'DefaultFigurePaperOrient', 'landscape')
```

## Printing Lines

My figure contains lines that use broken line styles. However, these lines print as solid lines.

Microsoft Windows 95 and Windows 98 do not support broken line styles for lines whose width is greater than 1 pixel. Unfortunately, most printers produce lines more than 1 pixel thick, so in most cases, Windows 95 and Windows 98 drivers produce solid lines, regardless of the setting of `LineStyleOrder`.

There are various ways you can work around this problem.

- Change the MATLAB default line width to 1 pixel wide, by adding this line to the `[MATLAB Settings]` section of your `MATLAB.INI` file:

```
ThinLineStyle=1
```

This will result in thin lines, but the lines will print with the specified styles.

- Set the figure's `Renderer` property to `OpenGL`:

```
set(gcf, 'Renderer', 'OpenGL')
```

The printed output will match the displayed figure. See “Setting the Rendering Method” for more information about the OpenGL renderer.

- Use a PostScript or Ghostscript printer driver. These drivers bypass the Windows Print Manager.

I want the lines in my figure to print in black but they keep printing in color.

You must be using a color printer driver. You can specify a black-and-white driver using the **Print** dialog box or `print` command, or you can use the **Page Setup** dialog box to force the lines for the current figure to print in black. See “Specifying Printed Color of Colored Lines and Text” for instructions on either method.

A white line in my figure keeps coming out black when I print it.

There are two things that can cause this to happen. Most likely, the line is positioned over a dark background. By default, MATLAB inverts your background to white when you print, and changes any white lines over the background to black. To avoid this, retain your background color when you print. See “Retaining Background Colors”.

The other possibility is that you are using a Windows printer driver and the printer is sending inaccurate color information to MATLAB. See “Correcting Color Results with Windows Drivers”.

### Printer

I am using a color printer, but my figure keeps printing in black and white.

By default, MATLAB uses a black-and-white printer driver. You need to specify a color printer driver. For instructions, see “Printer Drivers”. If you are already using a Windows color driver, the printer may be returning inaccurate information about its color property. See “Correcting Color Results with Windows Drivers”.

I have more than one printer connected to my system. How do I specify which one to print my figure with?

Use the **Print** dialog box. On UNIX, you can also use the `-P` switch with the print command. For instructions using either method, see “Selecting a Printer”.

## Rotated Text

I have some rotated text in my figure. It looks fine on the screen, but when I print it, the resolution is poor.

You are probably using bitmapped fonts, which don't rotate well. Try using TrueType fonts instead.

## ResizeFcn Warning

I get a warning about my `ResizeFcn` being used when I print my figure.

By default, MATLAB resizes your figure when converting it to printer coordinates. Therefore, MATLAB calls any `ResizeFcn` you have created for the figure and issues a warning. You can avoid this warning by setting the figure to print at screen size.

## Exporting Problems

### Background Color

I generated a figure with a black background and selected “Use figure color” from the Copy Options pane of the Preferences dialog box. But when I exported my figure, its background was changed to white.

You must have exported your figure to a file. The settings in **Copy Options** only apply to figures copied to the clipboard.

There are two ways to retain the displayed background color: use the **Page Setup** dialog box or set the `InvertHardCopy` property to off. See “Retaining Background Colors” for instructions on either method.

### Default Settings

I want to export all of my figures using the same size. Is there some way to do this so that I don't have to set the size for each individual figure?

You can set the default value for any property by adding a line to `startup.m`. Adding the following line sets the default figure size to 4-by-3 inches.

```
set(0,'DefaultFigurePaperPosition',[0 0 4 3]);
```

In your call to `set`, combine the word `Default` with the name of the object `Figure` and the property name `PaperPosition`.

I use the clipboard to export my figures as metafiles. Is there some way to force all of my copy operations to use the metafile format?

Use the **Copy Options** pane of the **Preferences** dialog box. Any settings made here, including whether MATLAB copies your figure as a metafile or bitmap, apply to all copy operations. See “Copy Options Preferences” for instructions.

### Microsoft Word

I exported my figure to an EPS file and then tried to import it into my Word document. My printout has an empty frame with an error message saying that my EPS picture was not saved with a preview and will only print to a PostScript printer. How do I include a TIFF preview?

Use the print command with the `-tiff` switch. For example,

```
print -deps -tiff filename
```

Note that if you print to a nonPostScript printer with Word, the preview image is used for printing. This is a low-resolution image that lacks the quality of an EPS graphic. For more information about preview images and other aspects of EPS files, see “EPS Files”.

When I try to resize my figure in Word, its quality suffers.

You must have used a bitmap format. Bitmap files generally do not resize well. If you are going to export using a bitmap format, try to set the figure's size while it's still in MATLAB. See “Size and Position of Printed or Exported Figures” for instructions.

As an alternative, you can use one of the vector formats, EMF or EPS. Figures exported in these formats can be resized in Word without affecting quality.

When I copy and paste figures into Word 97 and PowerPoint 97, they display correctly but do not print under Windows 95. I usually get a blank sheet of paper.



This is a bug that occurs when using the metafile format for clipboard export. Try using the bitmap clipboard format instead. If you use the graphical user interface, see “Clipboard Formats”. If you use MATLAB commands, see “Exporting to the Clipboard Using MATLAB Commands”.

I exported my figure as an EMF to the clipboard. When I paste it into Word, some of the labels are printed incorrectly.

This problem occurs with some versions of Word and Windows. Try editing the labels in Word.

### File Format

I tried to import my exported figure into a word processing document, but I got an error saying the file format is unrecognized.

There are two likely causes: you used the `print` command and forgot to specify the export format, or your word processing program does not support the export format. Include a format switch when you use the `print` command; simply including the file extension is not sufficient. For instructions, see “Setting the Export File Format”.

If this does not solve your problem, check what formats the word processor supports. Also see the table, “Editable Formats in Other Applications”, which lists some applications and the export formats they support.

I tried to append a figure to an EPS file, and received an error message.

You cannot append figures to an EPS file. The `-append` option is only valid for PostScript files, which should not be confused with EPS files. PostScript is a printer driver; EPS is a graphics file format.

Of the supported export formats, only HDF supports storing multiple figures, but you must use the `imwrite` command to append them. For an example, see the reference page for `imwrite`.

### Size of Exported File

I've always used the EPS format to export my figures, but recently it started to generate huge files. Some of my files are now several megabytes!

Your graphics have probably become complicated enough that MATLAB is using the OpenGL or Z-buffer renderer instead of the Painter's renderer. It

does this to improve display time or to handle attributes that Painter's cannot, such as lighting. However, using OpenGL or Z-buffer causes a bitmap to be stored in your EPS file, which sometimes leads to a large file.

There are two ways to fix the problem. You can specify the Painter's renderer when you export to EPS, or you can use a bitmap format, such as TIFF. The best renderer and type of format to use depend upon the figure. See "Bitmap and Vector Formats" if you need help deciding. For information about the rendering methods and how to set them, see "Setting the Rendering Method".

### Making Movies

I am processing a large number of frames in MATLAB. I would like these frames to be saved as individual files for later conversion into a movie. How can I do this?

Use `getframe` to capture the frames, `imwrite` to write them to a file, and `movie` to create a movie from the files. For more information about using `getframe` and `imwrite` to capture and write the frames, see "Using the `getframe` Command to Export a Graphic". For more information about creating a movie from the captured frames, see the reference page for `movie`.

You can also save multiple figures to an AVI file. AVI files can be used for animated sequences that do not need MATLAB to run. However, they do require an AVI viewer. For more information, see "Creating an AVI Format Movie" in "Working Environment for MATLAB."

### Extended Operations

There are some Export operations that cannot be performed using the Export dialog box.

You need to use the `print` command to do any of the following operations:

- Export to a supported file format not listed in the **Export** dialog box. The formats not available from the **Export** dialog box include HDF, some variations of BMP and PCX, and the raw data versions of PBM, PGM, and PPM. The second column of the table, Export Formats and Export-Only Options, indicates when a format is not available from the **Export** dialog box.
- Specify a resolution.
- Specify one of the following options: TIFF preview, loose bounding box for EPS files, compression quality for JPEG files, CMYK output on Windows.
- Perform batch exporting.

## General Problems

### Background Color

When I output my figure, its background is changed to white. How can I get it to have the displayed background color?

By default, when you print or export a figure, MATLAB inverts the background color to white. There are two ways to retain the displayed background color: use the **Page Setup** dialog box or set the `InvertHardCopy` property to `off`. See “Retaining Background Colors” for instructions on either method.

If you are exporting your figure to the clipboard, you can also use the **Copy Options** pane of the **Preferences** dialog box. Setting the background here sets it for all figures copied to the clipboard.

### Default Settings

I need to produce diagrams for publications. There is a list of requirements that I must meet for size of the figure, fonts types, etc. How can I do this easily and consistently?

You can set the default value for any property by adding a line to `startup.m`. As an example, the following line sets the default axes label font size to 12.

```
set(0, 'DefaultAxesFontSize', 12);
```

In your call to `set`, combine the word `Default` with the name of the object `Axes` and the property name `FontSize`.

### Dimensions of Output

The dimensions of my output are huge. How can I make it smaller?

Check your settings for figure size and resolution, both of which affect the output dimensions of your figure.

The default figure size is 8-by-6 inches. You can use the **Page Setup** dialog box or the `PaperPosition` property to set the figure size. See “Size and Position of Printed or Exported Figures”.

The default resolution depends on the export format or printer driver used. For example, built-in MATLAB bitmap formats, like TIFF, have a default resolution of 150 dpi. You can change the resolution by using the `print`

command and the `-r` switch. For default resolution values and instructions on how to change them, see “Setting Resolution”.

I selected “Match Screen Size” from the Page Setup menu, but my output looks a little bigger, and my font looks different.

You probably output your figure using a higher resolution than your screen uses. Set your resolution to be the same as the screen’s.

As an alternative, if you are exporting your figure, see if your application enables you to select a resolution. If so, import the figure at the same resolution it was exported with. For more information about resolution and how to set it when exporting, see “Setting Resolution”.

### Axis and Tick Labels

When I resize my figure below a certain size, my x-axis label and the bottom half of the x-axis tick labels are missing from the output.

Your figure size may be too small to accommodate the labels. Labels are positioned a fixed distance from the x-axis. Since the x-axis itself is positioned a relative distance away from the window’s edge, the label text may not fit. Try using a larger figure size or smaller fonts. For instructions on setting the size of your figure, see “Size and Position of Printed or Exported Figures”. For information about setting font size, the “Text Properties” reference page.

In my output, the x-axis has fewer ticks than it did on the screen.

MATLAB has rescaled your ticks because the size of your output figure is different from its displayed size. There are two ways to prevent this: select **Keep Screen Limits and Ticks** from the **Page Setup** dialog box or set the `XTickMode`, `YTickMode`, and `ZTickMode` properties to `manual`. See “Locking the Ticks and Limits of the Axes” for details.

### UI Controls

My figure contains UI Controls. How do I prevent them from appearing in my output?

Use the `print` command with the `-noui` switch. For details, see “Excluding User Interface Controls from Output”.

## Cropping

I can't output my figure using the uncropped setting (i.e. a loose BoundingBox).

Only PostScript printer drivers and the EPS export format support uncropped output. There is a workaround for Windows printer drivers, however. Using the print command, save your figure to a file that can be printed later. For an example see, "Printing an Uncropped Figure with a Windows Printer Driver".

## Text Object Font

I have a problem with text objects when printing with a PostScript printer driver or exporting to EPS. The fonts are correct on the screen, but are changed in the output.

You have probably used a font that is not supported by EPS and PostScript. All unsupported fonts are converted to Courier. See "PostScript and Ghostscript Supported Fonts" for the list of the supported fonts.



# Handle Graphics Objects

---

<b>Overview</b> . . . . .	7-2
<b>Graphics Object Hierarchy</b> . . . . .	7-3
<b>Types of Graphics Objects</b> . . . . .	7-4
<b>Object Properties</b> . . . . .	7-9
<b>Graphics Object Creation Functions</b> . . . . .	7-12
<b>Setting and Querying Property Values</b> . . . . .	7-18
<b>Setting Default Property Values</b> . . . . .	7-23
<b>Accessing Object Handles</b> . . . . .	7-30
<b>Controlling Graphics Output</b> . . . . .	7-37
<b>Saving Handles in M-Files</b> . . . . .	7-48
<b>Properties Changed by Built-In Functions</b> . . . . .	7-49

### Overview

This section discusses Handle Graphics objects and provides an introduction to programming with MATLAB's graphics and visualization features. It shows how to:

- Create objects
- Set and query object properties
- Define default values
- Obtain the handles of existing objects
- Control target window for graphics output



## Graphics Object Hierarchy

Handle Graphics objects are the basic drawing elements used by MATLAB to display data and to create graphical user interfaces (GUIs). Each instance of an object is associated with a unique identifier called a *handle*. Using this handle, you can manipulate the characteristics (called object *properties*) of an existing graphics object. You can also specify values for properties when you create a graphics object.

These objects are organized into a tree-structured hierarchy.

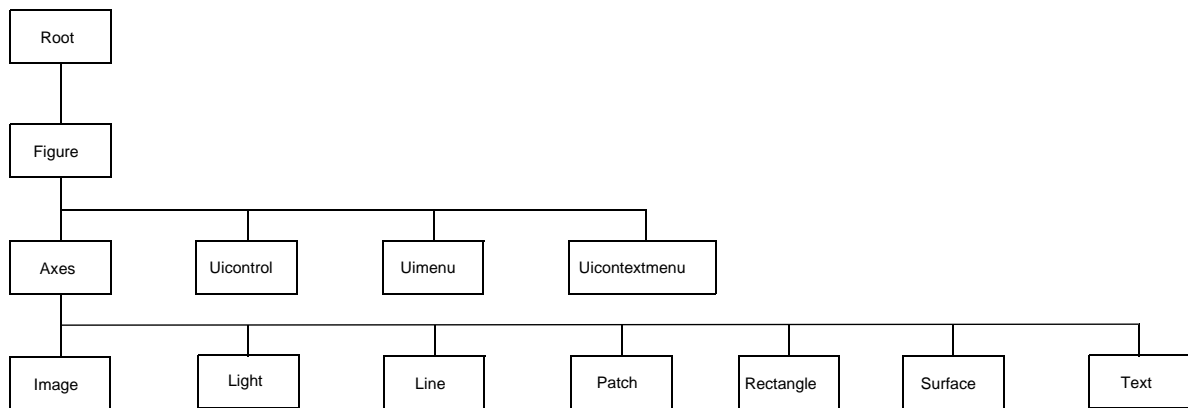

The hierarchical nature of Handle Graphics is based on the interdependencies of the various graphics objects. For example, to draw a line object, MATLAB needs an axes object to orient and provide a frame of reference to the line. The axes, in turn, needs a figure window to display the line.

## Types of Graphics Objects

Graphics objects are interdependent so the graphics display typically contains a variety of objects that, in conjunction, produce a meaningful graph or picture. The following picture of a figure window contains a number of graphics objects.

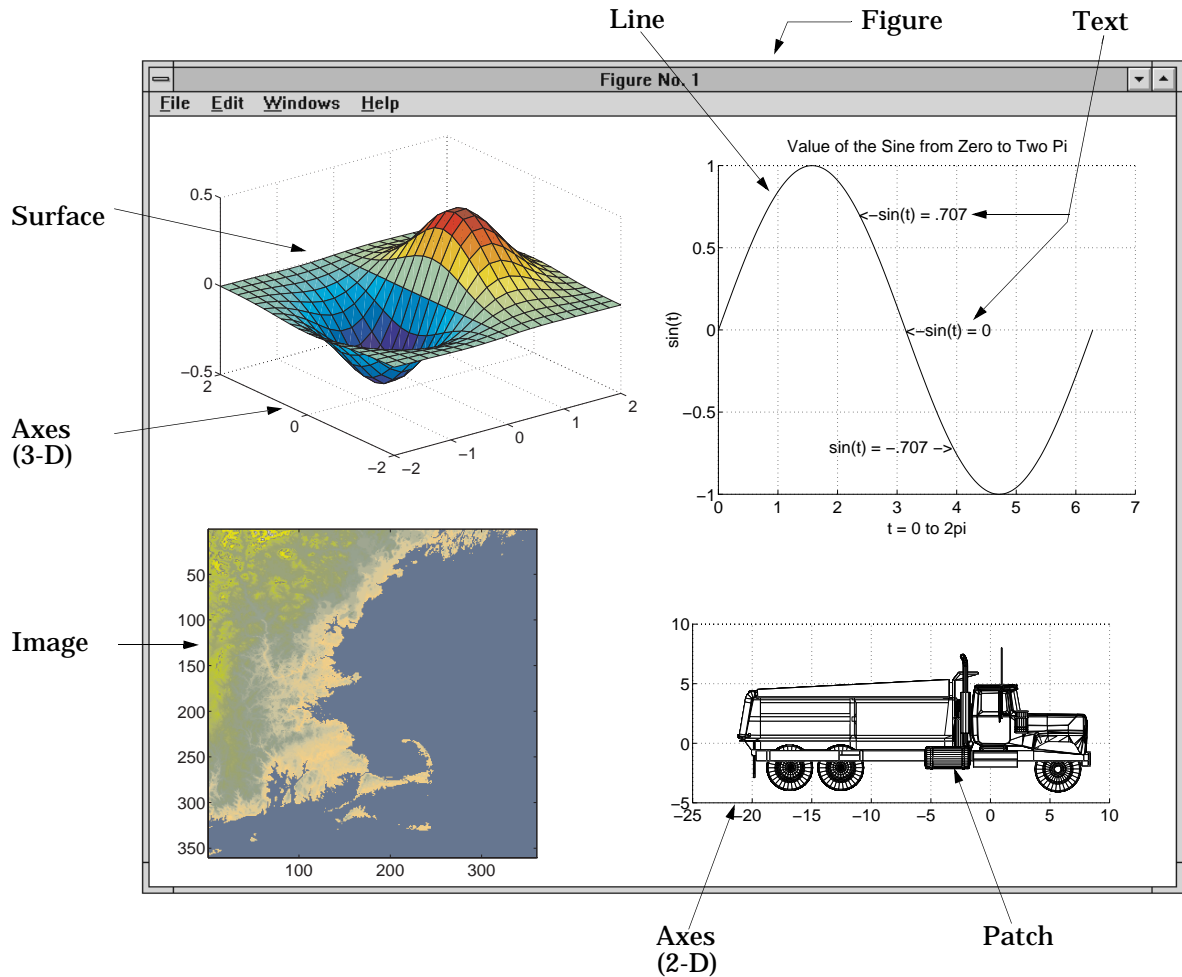

Each type of graphics object has a corresponding creation function that you use to create an instance of that class of object. Object creation functions have the same names as the objects they create (e.g., the `text` function creates text objects, the `figure` function creates figure objects, and so on).

## Handle Graphics Objects

The following list summarizes the Handle Graphics objects.

### The Root

At the top of the hierarchy is the root object. It corresponds to the computer screen. There is only one root object and all other objects are its descendants. You do not create the root object; it exists when you start MATLAB. You can, however, set the values of root properties and thereby affect the graphics display.

### Figure

Figure objects are the individual windows on the root screen where MATLAB displays graphics. MATLAB places no limits on the number of figure windows you can create (your computer may, however). All figures are children of the root and all other graphics objects are descendants of figures.

All functions that draw graphics (e.g., `plot` and `surf`) automatically create a figure if one does not exist. If there are multiple figures within the root, one figure is always designated as the “current” figure, and is the target for graphics output.

### Uicontrol

Uicontrol objects are user interface controls that execute callback routines when users activate the object. There are a number of styles of controls such as pushbuttons, listboxes, and sliders. Each device is designed to accept a certain type of information from users. For example, listboxes are typically used to provide a list of filenames from which you select one or more items for action carried out by the control’s callback routine.

You can use uicontrols in combinations to construct control panels and dialog boxes. Pop-up menus, editable text boxes, check boxes, pushbuttons, static text, and frames compose this particular example.

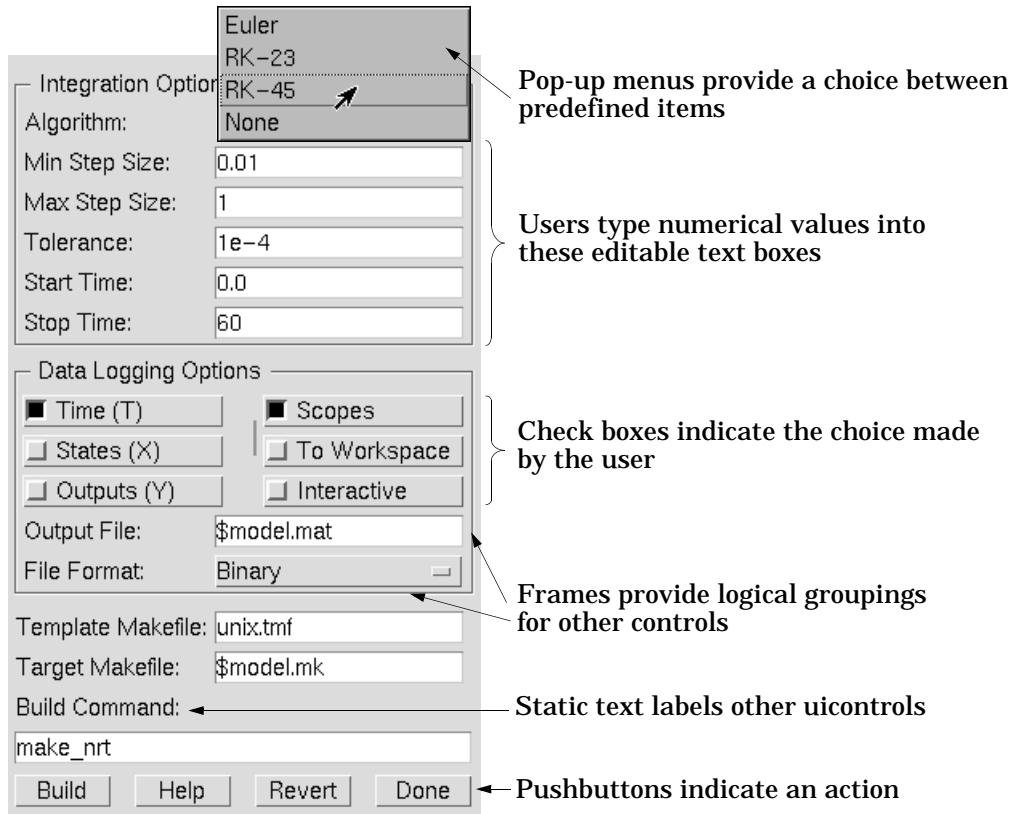

Uicontrol objects are children of figures and are therefore independent of axes.

### Uimenu

Uimenu objects are pull-down menus that execute callback routines when users select an individual menu item. MATLAB places uimenus on the figure window menu bar, to the right of existing menus defined by the system. This picture shows the top of an MS-Windows figure that has three top-level uimenus defined (titled **Workspace**, **Figure**, and **Axes**). Two levels of submenus are visible under **Workspace** top-level uimenu.

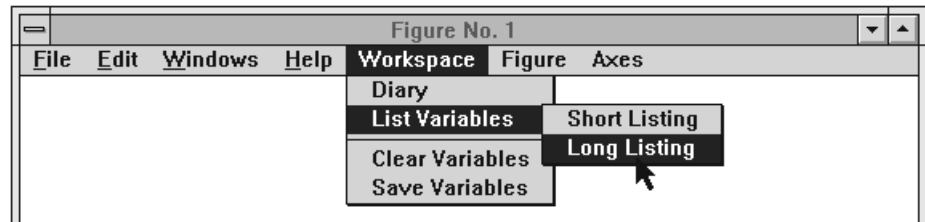

Uimenu are children of figures and are therefore independent of axes.

### Axes

Axes objects define a region in a figure window and orient their children within this region. axes are children of figures and are parents of image, light, line, patch, surface, and text objects.

All functions that draw graphics (e.g., plot, surf, mesh, and bar) create an axes object if one does not exist. If there are multiple axes within the figure, one axes is always designated as the “current” axes, and is the target for display of the above mentioned graphics objects (uicontrols and uimenu are not children of axes).

### Image

A MATLAB image consists of a data matrix and possibly a colormap. There are three basic image types that differ in the way that data matrix elements are interpreted as pixel colors – indexed, intensity, and truecolor. Since images are strictly 2-D, you can view them only at the default 2-D view.

### Light

Light objects define light sources that affect all patch and surface objects within the axes. You cannot see lights, but you can set properties that control the style of light source, color, location, and other properties common to all graphics objects.

### Line

Line objects are the basic graphics primitives used to create most 2-D and some 3-D plots. High-level functions plot, plot3, and loglog (and others) create line objects. The coordinate system of the parent axes positions and orients the line.

### Patch

Patch objects are filled polygons with edges. A single patch can contain multiple faces, each colored independently with solid or interpolated colors. `fill`, `fill3`, and `contour3` create patch objects. The coordinate system of the parent axes positions and orients the patch.

### Rectangle

Rectangle objects are 2-D filled areas having a shape that can range from a rectangle to an ellipse. Rectangles are useful for creating flow-chart type drawings.

### Surface

Surface objects are 3-D representations of matrix data created by plotting the value of each matrix element as a height above the  $x$ - $y$  plane. Surface plots are composed of quadrilaterals whose vertices are specified by the matrix data. MATLAB can draw surfaces with solid or interpolated colors or with only a mesh of lines connecting the points. The coordinate system of the parent axes positions and orients the surface.

The high-level function `pcolor` and the `surf` and `mesh` group of functions create surface objects.

### Text

Text objects are character strings. The coordinate system of the parent axes positions the text. The high-level functions `title`, `xlabel`, `ylabel`, `zlabel`, and `gtext` create text objects.

## Object Properties

A graphics object's properties control many aspects of its appearance and behavior. Properties include general information such as the object's type, its parent and children, whether it is visible, as well as information unique to the particular class of object.

For example, from any given figure object you can obtain the identity of the last key pressed in the window, the location of the pointer, or the handle of the most recently selected menu.

MATLAB organizes graphics information into a hierarchy and stores this information in properties. For example, root properties contain the handle of the current figure and the current location of the pointer (cursor), figure properties maintain lists of their descendants and keep track of certain events that occur within the window, and axes properties contain information about how each of its child objects uses the figure colormap and the color order used by the `plot` function.

### Changing Values

You can query the current value of any property and specify most property values (although some are set by MATLAB and are read only). Property values apply uniquely to a particular instance of an object; setting a value for one object does not change this value for other objects of the same type.

### Default Values

You can set default values that affect all subsequently created objects. Whenever you do not define a value for a property, either as a default or when you create the object, MATLAB uses "factory-defined" values.

The reference entry for each object creation function provides a complete list of the properties associated with that class of graphics object.

## Properties Common to All Objects

Some properties are common to all graphics objects, as illustrated in the following table.

Property	Information Contained
BusyAction	Controls the way MATLAB handles callback routine interruption defined for the particular object
ButtonDownFcn	Callback routine that executes when button press occurs
Children	Handles of all this object's children objects
Clipping	Mode that enables or disables clipping (meaningful only for axes children)
CreateFcn	Callback routine that executes when this type of object is created
DeleteFcn	Callback routine that executes when you issue a command that destroys the object
HandleVisibility	Allows you to control the availability of the object's handle from the command line and from within callback routines
Interruptible	Determines whether a callback routine can be interrupted by a subsequently invoked callback routine
Parent	The object's parent
Selected	Indicates whether object is selected
SelectionHighlight	Specifies whether object visually indicates the selection state
Tag	User-specified object label
Type	The type of object (figure, line, text, etc.)



---

<b>Property</b>	<b>Information Contained</b>
UserData	Any data you want to associate with the object
Visible	Determines whether or not the object is visible

## Graphics Object Creation Functions

Each graphics object (except the root object) has a corresponding creation function, named for the object it creates. This table lists the creation functions.

Function	Object Description
axes	Rectangular coordinate system that scales and orients axes children image, light, line, patch, surface, and text objects.
figure	Window for displaying graphics.
image	2-D picture defined by either colormap indices or RGB values. The data can be 8-bit or double precision data.
light	Directional light source located within the axes and affecting patches and surfaces.
line	Line formed by connecting the coordinate data with straight line segments, in the sequence specified.
patch	Polygonal shell created by interpreting each column in the coordinate matrices as a separate polygon.
rectangle	2-D filled area having a shape that can range from a rectangle to an ellipse.
surface	Surface created with rectangular faces defined by interpreting matrix elements as heights above a plane.
text	Character string located in the axes coordinate system.
uicontextmenu	Context menu that you can associate with other graphics object.

Function	Object Description
uicontrol	Programmable user-interface device, such as pushbutton, slider, or listbox.
uimenu	Programmable menu appearing at the top of a figure window.

All object creation functions have a similar format.

```
handle = function('propertyname',propertyvalue,...)
```

You can specify a value for any object property (except those that are read only) by passing property name/property value pairs as arguments. The function returns the handle of the object it creates, which you can use to query and modify properties after creating the object.

## Example – Creating Graphics Objects

This code evaluates a mathematical function and creates three graphics objects using the property values specified as arguments to the figure, axes, and surface commands. MATLAB uses default values for all other properties.

```
[x,y] = meshgrid([-2:.4:2]);
Z = x.*exp(-x.^2-y.^2);
fh = figure('Position',[350 275 400 300],'Color','w');
ah = axes('Color',[.8 .8 .8],'XTick',[-2 -1 0 1 2],...
         'YTick',[-2 -1 0 1 2]);
sh = surface('XData',x,'YData',y,'ZData',Z,...
           'FaceColor',get(ah,'Color')+1,...
           'EdgeColor','k','Marker','o',...
           'MarkerFaceColor',[.5 1 .85]);
```

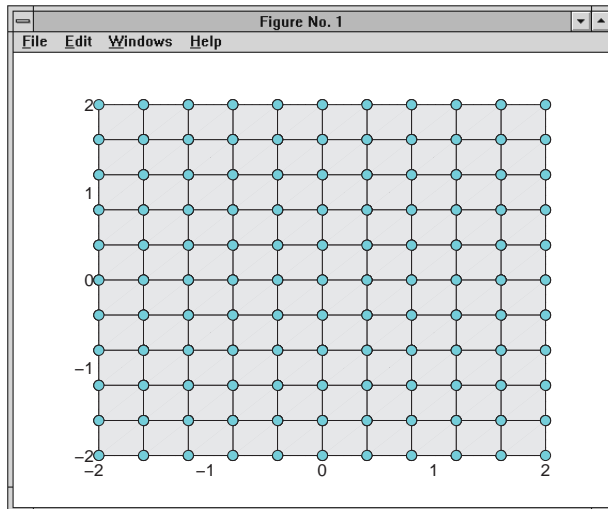

Note that the surface function does not use a 3-D view like the high-level surf functions. Object creation functions simply add new objects to the current axes without changing axes properties, except the `Children` property, which now includes the new object and the axis limits (`XLim`, `YLim`, and `ZLim`), if necessary.

You can change the view using the camera commands or use the `view` command.

```
view(3)
```

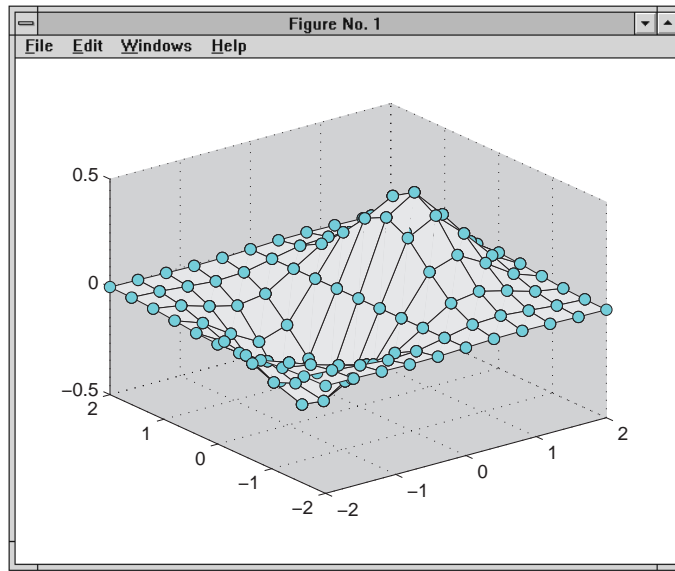

## Parenting

By default, all statements that create graphics objects do so in the current figure and the current axes (if the object is an axes child). However, you can specify the parent of an object when you create it. For example, the statement,

```
axes('Parent',figure_handle,...)
```

creates an axes in the figure identified by `figure_handle`. You can also move an object from one parent to another by redefining its `Parent` property.

```
set(gca,'Parent',figure_handle)
```

## High-Level Versus Low-Level

MATLAB's high-level graphics routines (e.g., `plot` or `surf`) call the appropriate object creation function to draw graphics objects. However, high-level routines also clear the axes or create a new figure, depending on the settings of the axes and figure `NextPlot` properties.

In contrast, object creation functions simply create their respective graphics objects and place them in the current parent object. They do not respect the setting of the figure or axes `NextPlot` property.

For example, if you call the `line` function,

```
line('XData',x,'YData',y,'ZData',z,'Color','r')
```

MATLAB draws a red line in the current axes using the specified data values. If there is no axes, MATLAB creates one. If there is no figure window in which to create the axes, MATLAB creates it as well.

If you call the `line` function a second time, MATLAB draws the second line in the current axes without erasing the first line. This behavior is different from high-level functions like `plot` that delete graphics objects and reset all axes properties (except `Position` and `Units`). You can change the behavior of high-level functions using the `hold` command or changing the setting of the axes `NextPlot` property.

See the “Controlling Graphics Output” section in this chapter for more information on this behavior and on using the `NextPlot` property.

## Simplified Calling Syntax

Object creation functions have convenience forms that allow you to use a simpler syntax. For example,

```
text(.5,.5,.5,'Hello')
```

is equivalent to,

```
text('Position',[.5 .5 .5],'String','Hello')
```

Note that using the convenience form of an object creation function can cause subtle differences in behavior when compared to formal property name/property value syntax.

### A Note About Property Names

By convention, MATLAB documentation capitalizes the first letter of each word that makes up a property name, such as `LineStyle` or `XTickLabelMode`. While this makes property names easier to read, MATLAB does not check for uppercase letters. In addition, you need use only enough letters to identify the name uniquely, so you can abbreviate most property names.

**In M-files, however, using the full property name can prevent problems with futures releases of MATLAB if a shortened name is no longer unique because of the addition of new properties.**

## Setting and Querying Property Values

The `set` and `get` functions specify and retrieve the value of existing graphics object properties. They also enable you to list possible values for properties that have a fixed set of values. (You can also use the Property Editor to set many property values. See “Using the Property Editor” on page 1-15 for more information.)

The basic syntax for setting the value of a property on an existing object is

```
set(object_handle, 'PropertyName', 'NewPropertyValue')
```

To query the current value of a specific object’s property, use a statement like

```
returned_value = get(object_handle, 'PropertyName');
```

Property names are always quoted strings. Property values depend on the particular property.

See the “Accessing Object Handles” section in this chapter and the `findobj` command for information on finding the handles of existing object.

### Setting Property Values

You can change the properties of an existing object using the `set` function and the handle returned by the creating function. For example, this statement moves the *y*-axis to the right side of the plot on the current axes.

```
set(gca, 'YAxisLocation', 'right')
```

If the handle argument is a vector, MATLAB sets the specified value on all identified objects.

You can specify property names and property values using structure arrays or cell arrays. This can be useful if you want to set the same properties on a number of objects. For example, you can define a structure to set axes properties appropriately to display a particular graph.

```
view1.CameraViewAngleMode = 'manual';  
view1.DataAspectRatio = [1 1 1];  
view1.ProjectionType = 'Perspective';
```

To set these values on the current axes, type

```
set(gca, view1)
```



### Listing Possible Values

You can use `set` to display the possible values for many properties without actually assigning a new value. For example, this statement obtains the values you can specify for line object markers.

```
set(obj_handle, 'Marker')
```

MATLAB returns a list of values for the `Marker` property for the type of object specified by `obj_handle`. Braces indicate the default value.

```
[ + | o | * | . | x | square | diamond | v | ^ | > | < | pentagram  
| hexagram | {none} ]
```

To see a list of all settable properties along with possible values of properties that accept string values, use `set` with just an object handle.

```
set(object_handle)
```

For example, for a surface object, MATLAB returns

```
CData  
CDataScaling: [ {on} | off]  
EdgeColor: [ none | {flat} | interp ] ColorSpec.  
EraseMode: [ {normal} | background | xor | none ]  
FaceColor: [ none | {flat} | interp | texturemap ] ColorSpec.  
LineStyle: [ {-} | — | : | -. | none ]  
.  
.  
.  
Visible: [ {on} | off ]
```

If you assign the output of the `set` function to a variable, MATLAB returns the output as a structure array. For example,

```
a = set(gca);
```

The field names in `a` are the object's property names and the field values are the possible values for the associated property. For example,

```
a.GridLineStyle  
ans =  
  
' - '
```

```
' : '  
' - . '  
' none '
```

returns the possible value for the axes grid line styles. Note that while property names are not case sensitive, MATLAB structure field names are. For example,

```
a.gridlinestyle  
??? Reference to non-existent field 'gridlinestyle'.
```

returns an error.

## Querying Property Values

Use `get` to query the current value of a property or of all the object's properties. For example, check the value of the current axes `PlotBoxAspectRatio` property.

```
get(gca, 'PlotBoxAspectRatio')  
  
ans =  
     1     1     1
```

MATLAB lists the values of all properties, where practical. However, for properties containing data, MATLAB lists the dimensions only (for example, `CurrentPoint` and `ColorOrder`).

```
AmbientLightColor = [1 1 1]  
Box = off  
CameraPosition = [0.5 0.5 2.23205]  
CameraPositionMode = auto  
CameraTarget = [0.5 0.5 0.5]  
CameraTargetMode = auto  
CameraUpVector = [0 1 0]  
CameraUpVectorMode = auto  
CameraViewAngle = [32.2042]  
CameraViewAngleMode = auto  
CLim: [0 1]  
CLimMode: auto  
Color: [0 0 0]  
CurrentPoint: [ 2x3 double]  
ColorOrder: [ 7x3 double]
```

```

    .
    .
    .
Visible = on

```

### Querying Individual Properties

You can obtain the data from the property by getting that property individually.

```

get(gca, 'ColorOrder')
ans =
     0         0    1.0000
     0    0.5000         0
    1.0000         0         0
     0    0.7500    0.7500
    0.7500         0    0.7500
    0.7500    0.7500         0
    0.2500    0.2500    0.2500

```

### Returning a Structure

If you assign the output of `get` to a variable, MATLAB creates a structure array whose field names are the object property names and whose field values are the current values of the named property.

For example, if you plot some data, `x` and `y`,

```
h = plot(x,y);
```

and get the properties of the line object created by `plot`,

```
a = get(h);
```

you can access the values of the line properties using the field name. This call to the `text` command places the string 'x and y data' at the first data point and colors the text to match the line color.

```
text(x(1),y(1), 'x and y data', 'Color', a.Color)
```

If `x` and `y` are matrices, `plot` draws one line per column. To label the plot of the second column of data, reference that line.

```
text(x(1,2),y(1,2), 'Second set of data', 'Color', a(2).Color)
```

### Querying Groups of Properties

You can define a cell array of property names and conveniently use it to obtain the values for those properties. For example, suppose you want to query the values of the axes “camera mode” properties. First define the cell array.

```
camera_props(1) = {'CameraPositionMode'};  
camera_props(2) = {'CameraTargetMode'};  
camera_props(3) = {'CameraUpVectorMode'};  
camera_props(4) = {'CameraViewAngleMode'};
```

Use this cell array as an argument to obtain the current values of these properties.

```
get(gca,camera_props)  
ans =  
    'auto' 'auto' 'auto' 'auto'
```

### Factory-Defined Property Values

MATLAB defines values for all properties, which are used if you do not specify values as arguments or as defaults. You can obtain a list of all factory-defined values with the statement.

```
a = get(0,'Factory');
```

`get` returns a structure array whose field names are the object type and property name concatenated together, and field values are the factory value for the indicated object and property. For example, this field,

```
UimenuSelectionHighlight: 'on'
```

indicates that the factory value for the `SelectionHighlight` property on `uimenu` objects is `on`.

You can get the factory value of an individual property with,

```
get(0,'FactoryObjectTypePropertyName')
```

For example,

```
get(0,'FactoryTextFontName')
```

## Setting Default Property Values

All object properties have “default” values built into MATLAB (i.e., factory-defined values). You can also define your own default values at any point in the object hierarchy.

### How MATLAB Searches for Default Values

MATLAB’s search for a default value begins with the current object and continues through the object’s ancestors until it finds a user-defined default value or until it reaches the factory-defined value. Therefore, a search for property values is always satisfied.

The closer to the root of the hierarchy you define the default, the broader its scope. If you specify a default value for line objects on the root level, MATLAB uses that value for all lines (since the root is at the top of the hierarchy). If you specify a default value for line objects on the axes level, then MATLAB uses that value for line objects drawn only in that axes.

If you define default values on more than one level, the value defined on the closest ancestor takes precedence since MATLAB terminates the search as soon as it finds a value.

Note that setting default values affects only those objects created after you set the default. Existing graphics objects are not affected.

This diagram shows the steps MATLAB follows in determining the value of a graphics object property.

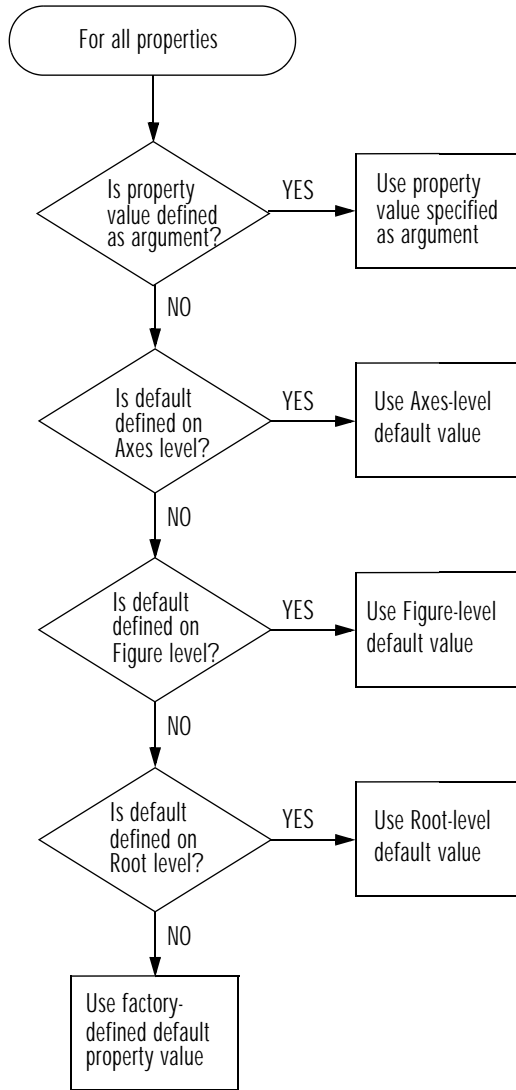

## Defining Default Values

To specify default values, create a string beginning with the word `Default` followed by the object type and finally the object property. For example, to specify a default value of 1.5 points for the line `LineWidth` property at the level of the current figure, use the statement,

```
set(gcf, 'DefaultLineLineWidth', 1.5)
```

The string, `DefaultLineLineWidth` identifies the property as a line property. To specify the figure color, use `DefaultFigureColor`. Note that it is meaningful to specify a default figure color only on the root level.

```
set(0, 'DefaultFigureColor', 'b')
```

Use `get` to determine what default values are currently set on any given object level; for example,

```
get(gcf, 'default')
```

returns all default values set on the current figure.

## Setting Properties to the Default

Specifying a property value of `'default'` sets the property to the first encountered default value defined for that property. For example, these statements result in a green surface `EdgeColor`,

```
set(0, 'DefaultSurfaceEdgeColor', 'k')
h = surface(peaks);
set(gcf, 'DefaultSurfaceEdgeColor', 'g')
set(h, 'EdgeColor', 'default')
```

Since a default value for surface `EdgeColor` exists on the figure level, MATLAB encounters this value first and uses it instead of the default `EdgeColor` defined on the root.

## Removing Default Values

Specifying a property value of `'remove'` gets rid of user-defined default values. The statement,

```
set(0, 'DefaultSurfaceEdgeColor', 'remove')
```

removes the definition of the default `Surface EdgeColor` from the root.

### Setting Properties to Factory-Defined Values

Specifying a property value of 'factory' sets the property to its factory-defined value. (The property descriptions provides access to the factory settings for properties having predefined sets of values.)

For example, these statements set the `EdgeColor` of surface `h` to black (its factory setting) regardless of what default values you have defined.

```
set(gcf,'DefaultSurfaceEdgeColor','g')
h = surface(peaks);
set(h,'EdgeColor','factory')
```

### Reserved Words

Setting a property value to `default`, `remove`, or `factory` produces the effect described in the previous sections. To set a property to one of these words (e.g., a text or `uicontrol` `String` property set to the word "Default"), you must precede the word with the backslash character. For example,

```
h = uicontrol('Style','edit','String','\Default');
```

### Examples – Setting Default LineStyles

The `plot` function cycles through the colors defined by the axes `ColorOrder` property when displaying multiline plots. If you define more than one value for the axes `LineStyleOrder` property, MATLAB increments the linestyle after each cycle through the colors.

You can set default property values that cause the `plot` function to produce graphs using varying linestyles, but not varying colors. This is useful when working on a monochrome display or printing on a black and white printer.

#### First Example

This example creates a figure with a white plot (axes) background color, then sets default values for axes objects on the root level.

```
whitebg('w') %create a figure with a white color scheme
set(0,'DefaultAxesColorOrder',[0 0 0],...
    'DefaultAxesLineStyleOrder','-|—|:|-.')
```

Whenever you call `plot`,

```
Z = peaks; plot(1:49,Z(4:7,:))
```



it uses one color for all data plotted because the axes `ColorOrder` contains only one color, but cycles through the `LineStyleOrder`.

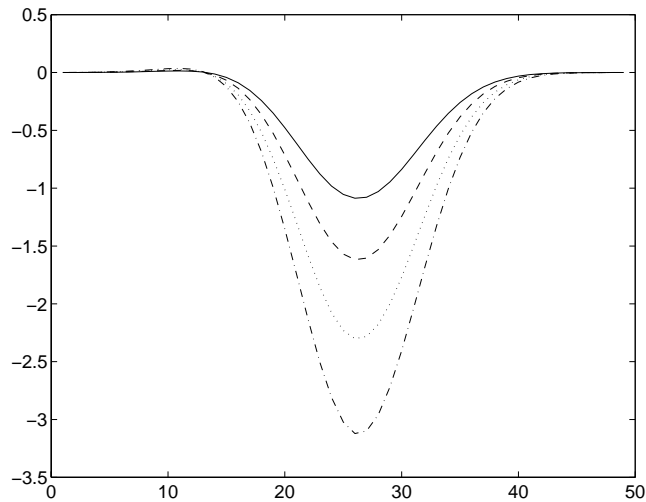

### Second Example

This example sets default values on more than one level in the hierarchy. These statements create two axes in one figure window, setting default values on the figure level and the axes level.

```
t = 0:pi/20:2*pi;
s = sin(t);
c = cos(t);
% Set default value for axes Color property
figh = figure('Position',[30 100 800 350],...
             'DefaultAxesColor',[.8 .8 .8]);

axh1 = subplot(1,2,1); grid on
% Set default value for line LineStyle property in first axes
set(axh1,'DefaultLineStyle','-.')
line('XData',t,'YData',s)
line('XData',t,'YData',c)
text('Position',[3 .4],'String','Sine')
text('Position',[2 -.3],'String','Cosine',...
```

```

        'HorizontalAlignment','right')

axh2 = subplot(1,2,2); grid on
% Set default value for text Rotation property in second axes
set(axh2,'DefaultTextRotation',90)
line('XData',t,'YData',s)
line('XData',t,'YData',c)
text('Position',[3 .4],'String','Sine')
text('Position',[2 -.3],'String','Cosine',...
     'HorizontalAlignment','right')

```

Issuing the same line and text statements to each subplot region results in a different display, reflecting different default settings.

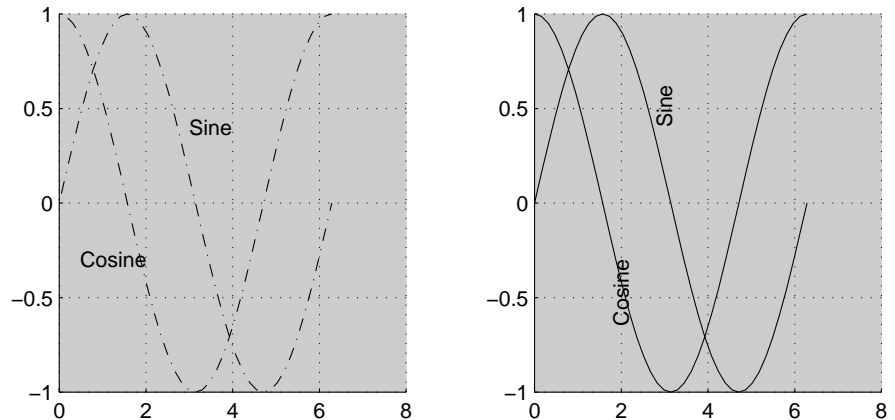

Since the default axes `Color` property is set on the figure level of the hierarchy, MATLAB creates both axes with the specified gray background color.

The axes on the left (subplot region 121) defines a dash-dot line style (`-.`) as the default, so each call to the `line` function uses dash-dot lines. The axes on the right does not define a default linestyle so MATLAB uses solid lines (the factory setting for lines).

The axes on the right defines a default text `Rotation` of 90 degrees, which rotates all text by this amount. MATLAB obtains all other property values from their factory settings, which results in nonrotated text on the left.

**To install default values whenever you run MATLAB, specify them in your `startup.m` file. Note that MATLAB may install default values for some appearance properties when started by calling the `colordef` command.**

## Accessing Object Handles

MATLAB assigns a handle to every graphics object it creates. All object creation functions optionally return the handle of the created object. If you want to access the object's properties (e.g., from an M-file) you should assign its handle to a variable at creation time to avoid searching for it later. However, you can always obtain the handle of an existing object with the `findobj` function or by listing its parent's `Children` property. The "Protecting Figures and Axes" section in this chapter provides for more information on how object handles are hidden from normal access.

The root object's handle is always zero. The handle of a figure is either:

- An integer that, by default, displays in the window title bar
- A floating point number requiring full MATLAB internal precision

The figure `IntegerHandle` property controls which type of handle the figure receives.

All other graphics object handles are floating-point numbers. You must maintain the full precision of these numbers when you reference handles. Rather than attempting to read handles off the screen and retype them, it is necessary to store the value in a variable and pass that variable whenever a handle is required.

### The Current Figure, Axes, and Object

An important concept in Handle Graphics is that of being current. The current figure is the window designated to receive graphics output. Likewise, the current axes is the target for commands that create axes children. The current object is the last graphics object created or clicked on by the mouse.

MATLAB stores the three handles corresponding to these objects in the ancestor's property list.

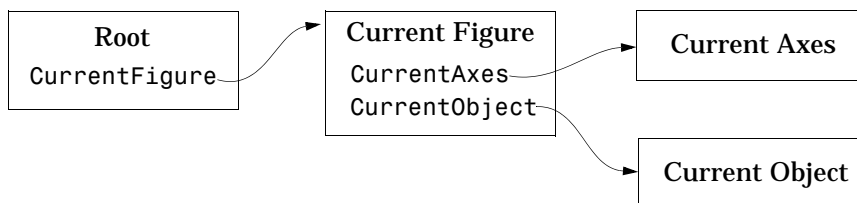

These properties enable you to obtain the handles of these key objects.

```

get(0, 'CurrentFigure');
get(gcf, 'CurrentAxes');
get(gcf, 'CurrentObject');
  
```

The following commands are shorthand notation for the get statements.

- `gcf` – returns the value of the root `CurrentFigure` property
- `gca` – returns the value of the current figure's `CurrentAxes` property
- `gco` – returns the value of the current figure's `CurrentObject` property

You can use these commands as input arguments to functions that require object handles. For example, you can click on a line object and then use `gco` to specify the handle to the `set` command,

```
set(gco, 'Marker', 'square')
```

or list the values of all current axes properties with

```
get(gca)
```

You can get the handles of all the graphic objects in the current axes (except those with hidden handles),

```
h = get(gca, 'Children');
```

and then determine the types of the objects.

```

get(h, 'type')
ans =
    'text'
    'patch'
    'surface'
    'line'
  
```

While `gcf` and `gca` provide a simple means of obtaining the current figure and axes handles, they are less useful in M-files. This is particularly true if your M-file is part of an application layered on MATLAB where you do not necessarily have knowledge of user actions that can change these values.

See the “Controlling Graphics Output” section in this chapter for information on how to prevent users from accessing the handles of graphics objects that you want to protect.

## Searching for Objects by Property Values — `findobj`

The `findobj` function provides a means to traverse the object hierarchy quickly and obtain the handles of objects having specific property values. If you do not specify a starting object, `findobj` searches from the root object, finding all occurrences of the property name/property value combination you specify.

### Example – Finding Objects

This plot of the sine function contains text objects labeling particular values of function.

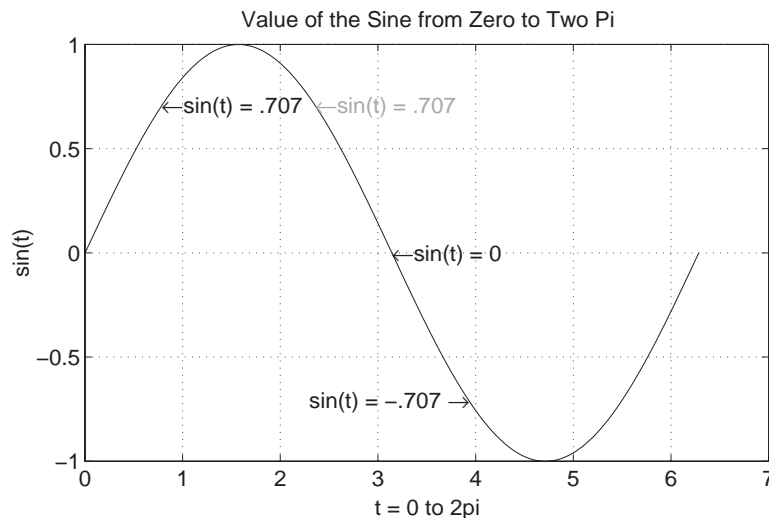

Suppose you want to move the text string labeling the value  $\sin(t) = .707$  from its current location at  $[\pi/4, \sin(\pi/4)]$  to the point  $[3\pi/4, \sin(3\pi/4)]$

where the function has the same value (shown grayed out in the picture). To do this, you need to determine the handle of the text object labeling that point and change its `Position` property.

To use `findobj`, pick a property value that uniquely identifies the object. In this case, the text `String` property.

```
text_handle = findobj('String','\leftarrow sin(t) = .707');
```

Next move the object to the new position, defining the text `Position` in axes units.

```
set(text_handle,'Position',[3*pi/4,sin(3*pi/4),0])
```

`findobj` also lets you restrict the search by specifying a starting point in the hierarchy, instead of beginning with the root object. This results in faster searches if there are many objects in the hierarchy. In the previous example, you know the text object of interest is in the current axes so you can type

```
text_handle = findobj(gca,'String','\leftarrow sin(t) = .707');
```

## Copying Objects

You can copy objects from one parent to another using the `copyobj` function. The new object differs from the original object only in the value of its `Parent` property and its handle; it is otherwise a clone of the original. You can copy a number of objects to a new parent, or one object to a number of new parents as long as the result maintains the correct parent/child relationship.

When you copy an object having children objects, MATLAB copies all children as well.

### Example – Copying Objects

Suppose you are plotting a variety of data and want to label the point having the  $x$ - and  $y$ -coordinates determined by  $5\pi \div 4$ ,  $\sin(5\pi \div 4)$  in each plot. The `text` function allows you to specify the location of the label in the coordinates defined by the  $x$ - and  $y$ -axis limits, simplifying the process of locating the text.

```
text('String','\{5\pi\div4, sin(5\pi\div4)\}\rightarrow',...
     'Position',[5*pi/4,sin(5*pi/4),0],...
     'HorizontalAlignment','right')
```

In this statement, the `text` function:

- Labels the data point with the string  $\{5\pi \div 4, \sin(5\pi \div 4)\}$  using TeX commands to draw a right-facing arrow and mathematical symbols.
- Specifies the Position in terms of the data being plotted.
- Places the data point to the right of the text string by changing the `HorizontalAlignment` to `right` (the default is `left`).

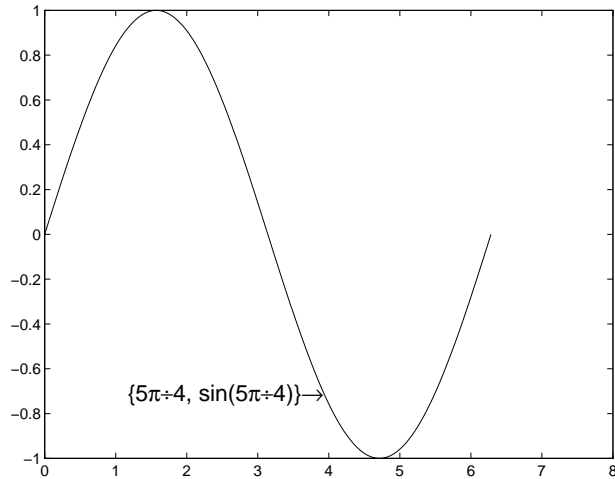

To label the same point with the same string in another plot, copy the text using `copyobj`. Since the last statement did not save the handle to the text object, you can find it using `findobj` and the `'String'` property.

```
text_handle = findobj('String',...  
                    '\{5\pi\div4,\sin(5\pi\div4)\}\rightarrow');
```

After creating the next plot, add the label by copying it from the first plot.

```
copyobj(text_handle,gca).
```



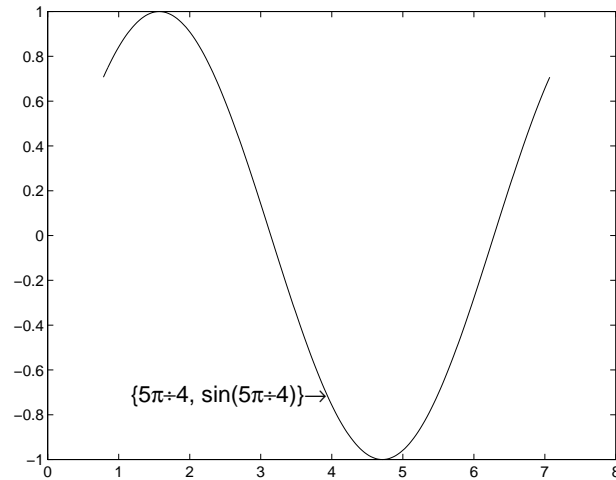

This particular example takes advantage of the fact that text objects define their location in the axes' data space. Therefore the text `Position` property did not need to change from one plot to another.

## Deleting Objects

You can remove a graphics object with the `delete` command, using the object's handle as an argument. For example, you can delete the current axes (and all of its descendants) with the statement

```
delete(gca)
```

You can use `findobj` to get the handle of a particular object you want to delete. For example, to find the handle of the dotted line in this multiline plot,

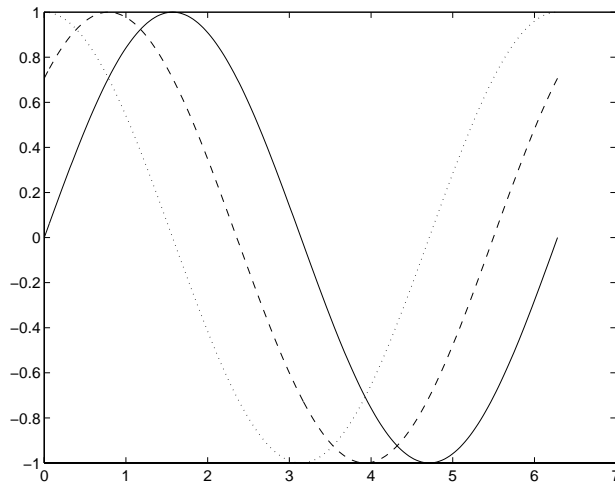

use `findobj` to locate the object whose `LineStyle` property is `'.'`

```
line_handle = findobj('LineStyle',':');
```

then use this handle with the `delete` command.

```
delete(line_handle)
```

You can combine these two statements, substituting the `findobj` statement for the handle.

```
delete(findobj('LineStyle',':'))
```

## Controlling Graphics Output

MATLAB allows many figure windows to be open simultaneously during a session. A MATLAB application may create figures to display graphical user interfaces as well as plotted data. It is necessary then to protect some figures from becoming the target for graphics display and to prepare (e.g., reset properties and clear existing objects from) others before receiving new graphics.

This section discusses how to control where and how MATLAB displays graphics output. Topics include:

- Specifying the target for graphics output
- Preparing the figure and axes to accept new objects
- Protecting figures and axes from becoming targets
- Accessing the handles of protected figure and axes

### Specifying the Target for Graphics Output

By default, MATLAB functions that create graphics objects display them in the current figure and current axes (if an axes child). You can direct the output to another parent by explicitly specifying the `Parent` property with the creating function. For example,

```
plot(1:10, 'Parent', axes_handle)
```

where `axes_handle` is the handle of the target axes. The `uicontrol` and `uimenu` functions have a convenient syntax that enables you to specify the parent as the first argument,

```
uicontrol(Figure_handle,...)
uimenu(parent_menu_handle,...)
```

or you can set the `Parent` property.

### Preparing Figures and Axes for Graphics

By default, commands that generate graphics output display the graphics objects in the current figure without clearing or resetting figure properties. However, if the graphics objects are axes children, MATLAB clears the axes and resets most axes properties to their default values before displaying the objects.

You can change this behavior by setting the figure and axes `NextPlot` properties.

### Using `NextPlot` to Control Output Target

MATLAB high-level graphics functions check the value of the `NextPlot` properties to determine whether to add, clear, or clear and reset the figure and axes before drawing. Low-level object creation functions do not check the `NextPlot` properties. They simply add the new graphics objects to the current figure and axes.

Low-level functions are designed primarily for use in M-files where you can implement whatever drawing behavior you want. However, when you develop a MATLAB-based application, controlling MATLAB's drawing behavior is essential to creating a program that behaves predictably.

This table summarizes the possible values for the `NextPlot` property.

<b>NextPlot</b>	<b>Figure</b>	<b>Axes</b>
add	Add new graphics objects without clearing or resetting the current figure. (Default setting)	Add new graphics objects without clearing or resetting the current axes.
replacechildren	Remove all child objects, but do not reset figure properties. Equivalent to <code>clf</code> .	Remove all child objects, but do not reset axes properties. Equivalent to <code>cla</code> .
replace	Remove all child objects and reset figure properties to their defaults. Equivalent to <code>clf reset</code> .	Remove all child objects and reset axes properties to their defaults. Equivalent to <code>cla reset</code> . (Default setting)

Note that a `reset` returns all properties, except `Position` and `Units`, to their default values.

The `hold` command provides convenient access to the `NextPlot` properties. The statement

```
hold on
```

sets both figure and axes `NextPlot` to `add`.

The statement

```
hold off
```

sets the axes `NextPlot` property to `replace`.

## Targeting Graphics Output with `newplot`

MATLAB provides the `newplot` function to simplify the process of writing graphics M-files that conform to the settings of the `NextPlot` properties.

`newplot` checks the values of the `NextPlot` properties and takes the appropriate action based on these values. You should place `newplot` at the beginning of any M-file that calls object creation functions.

When your M-file calls `newplot`, the following possible actions occur:

- 1 `newplot` checks the current figure's `NextPlot` property:
  - If there are no figures in existence, `newplot` creates one and makes it the current figure.
  - If the value of `NextPlot` is `add`, `newplot` makes the figure the current figure.
  - If the value of `NextPlot` is `replacechildren`, `newplot` deletes the figure's children (axes objects and their descendents) and makes this figure the current figure.
  - If the value of `NextPlot` is `replace`, `newplot` deletes the figure's children, resets the figure's properties to the defaults, and makes this figure the current figure.
- 2 `newplot` checks the current axes' `NextPlot` property:
  - If there are no axes in existence, `newplot` creates one and makes it the current axes.
  - If the value of `NextPlot` is `add`, `newplot` makes the axes the current axes.
  - If the value of `NextPlot` is `replacechildren`, `newplot` deletes the axes' children and makes this axes the current axes.
  - If the value of `NextPlot` is `replace`, `newplot` deletes the axes' children, resets the axes' properties to the defaults, and makes this axes the current axes.

### MATLAB's Default Behavior

Consider the default situation where the figure `NextPlot` property is `add` and the axes `NextPlot` property is `replace`. When you call `newplot`, it:

- 1 Checks the value of the current figure's `NextPlot` property (which is `add`) and determines MATLAB can draw into the current figure with no further action (if there is no current figure, `newplot` creates one, but does not recheck its `NextPlot` property).
- 2 Checks the value of the current axes' `NextPlot` property (which is `replace`), deletes all graphics objects from the axes, reset all axes properties (except `Position` and `Units`) to their defaults, and returns the handle of the current axes.

### Example – Using `newplot`

To illustrate the use of `newplot`, this example creates a function that is similar to the built-in `plot` function, except it automatically cycles through different line styles instead of using different colors for multiline plots.

```
function my_plot(x,y)
cax = newplot; % newplot returns handle of current axes
LSO = ['- ' ; '-- ' ; ':' ; '-.'];
set(cax, 'FontName', 'Times', 'FontAngle', 'italic')
set(get(cax, 'Parent'), 'MenuBar', 'none') %
line_handles = line(x,y, 'Color', 'b');
style = 1;
for i = 1:length(line_handles)
    if style > length(LSO), style = 1;end
    set(line_handles(i), 'LineStyle', LSO(style,:))
    style = style + 1;
end
grid on
```

The function `my_plot` uses the high-level line function syntax to plot the data. This provides the same flexibility in input argument dimension that the built-in `plot` function supports. The `line` function does not check the value of the figure or axes `NextPlot` property. However, because `my_plot` calls `newplot`, it behaves the same way the high-level `plot` function does – with default values in place, `my_plot` clears and resets the axes each time you call it.

`my_plot` uses the handle returned by `newplot` to access the target figure and axes. This example sets axes font properties and disables the figure's menu bar. Note how the figure handle is obtained via the axes Parent property.

This picture shows typical output for the `my_plot` function.

```
my_plot(1:10,peaks(10))
```

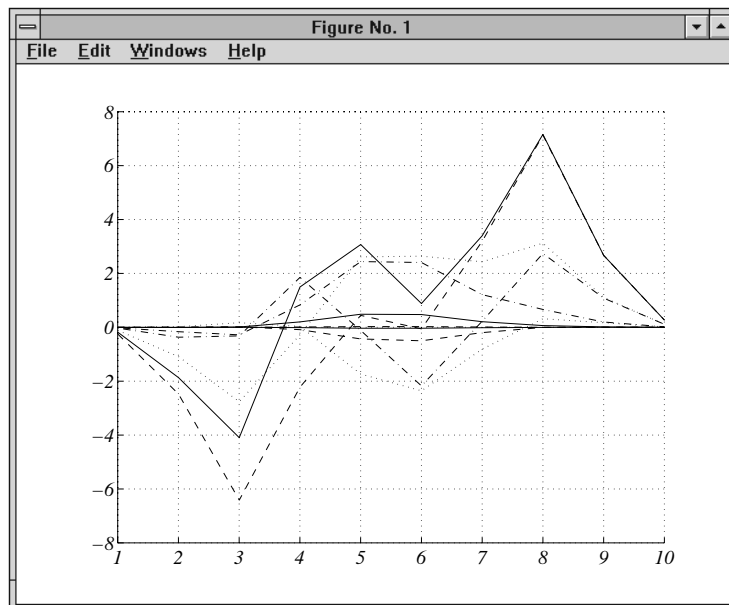

### Basic Plotting M-file Structure

This example illustrates the basic structure of graphics M-files:

- Call `newplot` early to conform to the `NextPlot` properties and to obtain the handle of the target axes.
- Reference the axes handle returned by `newplot` to set any axes properties or to obtain the figure's handle.
- Call object creation functions to draw graphics objects with the desired characteristics.

MATLAB's default settings for the `NextPlot` properties facilitate writing M-files that adhere to MATLAB's standard behavior: reuse the figure window, but clear and reset the axes with each new graph. Other values for these properties allow you to implement different behaviors.

### Replacing Only the Children Objects — `replacechildren`

The `replacechildren` value for `NextPlot` causes `newplot` to remove child objects from the figure or axes, but does not reset any property values (except the list of handles contained in the `Children` property).

This can be useful after setting properties you want to use for subsequent graphs without having to reset properties. For example, if you type on the command line

```
set(gca, 'ColorOrder', [0 0 1], 'LineStyleOrder', '-|--|:|-.', ...
      'NextPlot', 'replacechildren')
plot(x,y)
```

`plot` produces the same output as the M-file `my_plot` in the previous section, but only within the current axes. Calling `plot` still erases the existing graph (i.e., deletes the axes children), but it does not reset axes properties. The values specified for the `ColorOrder` and `LineStyleOrder` properties remain in effect.

### Testing for Hold State

There are situations in which your M-file should change the visual appearance of the axes to accommodate new graphics objects. For example, if you want the M-file `my_plot` from the previous example to accept 3-D data, it makes sense to set the view to 3-D when the input data has *z*-coordinates.

However, to be consistent with the behavior of MATLAB's high-level routines, it is a good practice to test if `hold` is on before changing parent axes or figure properties. When `hold` is on, the axes and figure `NextPlot` properties are both set to add.

The M-file, `my_plot3`, accepts 3-D data and also checks the hold state, using `ishold`, to determine if it should change the view.

```
function my_plot3(x,y,z)
cax = newplot;
hold_state = ishold; % ishold tests the current hold state
LSO = ['- ' ; '--' ; ':' ; '-.'];
```



```

if nargin == 2
    hlines = line(x,y,'Color','k');
    if ~hold_state % Change view only if hold is off
        view(2)
    end
elseif nargin == 3
    hlines = line(x,y,z,'Color','k');
    if ~hold_state % Change view only if hold is off
        view(3)
    end
end
ls = 1;
for hindex = 1:length(hlines)
    if ls > length(LSO),ls = 1;end
    set(hlines(hindex),'LineStyle',LSO(ls,:))
    ls = ls + 1;
end

```

If hold is on when you call `my_plot3`, it does not change the view. If hold is off, `my_plot3` sets the view to 2-D or 3-D, depending on whether there are two or three input arguments.

## Protecting Figures and Axes

There are situations in which it is important to prevent particular figures or axes from becoming the target for graphics output (i.e., preventing them from becoming the `gcf` or `gca`). An example is a figure containing the `uicontrols` that implement a user interface.

You can prevent MATLAB from drawing into a particular figure or axes by removing its handle from the list of handles that are visible to the `newplot` function, as well as any other functions that either return or implicitly reference handles (i.e., `gca`, `gcf`, `gco`, `cla`, `clf`, `close`, and `findobj`). Two properties control handle hiding: `HandleVisibility` and `ShowHiddenHandles`.

### HandleVisibility Property

`HandleVisibility` is a property of all objects. It controls the scope of handle visibility within three different ranges. Property values can be:

- `on` – The object's handle is available to any function executed on the MATLAB command line or from an M-file. This is the default setting.

- `callback` – The object's handle is hidden from all functions executing on the command line, even if it is on the top of the screen stacking order. However, during callback routine execution (MATLAB statements or functions that execute in response to user action), the handle is visible to all functions, such as `gca`, `gcf`, `gco`, `findobj`, and `newplot`. This setting enables callback routines to take advantage of MATLAB's handle access functions, while ensuring that users typing at the command line do not inadvertently disturb a protected object.
- `off` – The object's handle is hidden from all functions executing on the command line and in callback routines. This setting is useful when you want to protect objects from possibly damaging user commands.

For example, if a GUI accepts user input in the form of text strings, which are then evaluated (using the `eval` function) from within the callback routine, a string such as `'close all'` could destroy the GUI. To protect against this situation, you can temporarily set `HandleVisibility` to `off` on key objects.

```
user_input = get(editbox_handle,'String');
set(gui_handles,'HandleVisibility','off')
eval(user_input)
set(gui_handles,'HandleVisibility','commandline')
```

**Values Returned by `gca` and `gcf`.** When a protected figure is topmost on the screen, but has nonprotected figures stacked beneath it, `gcf` returns the topmost unprotected figure in the stack. The same is true for `gca`. If no unprotected figures or axes exist, calling `gcf` or `gca` causes MATLAB to create one in order to return its handle.

### Accessing Protected Objects

The root `ShowHiddenHandles` property enables and disables handle visibility control. By default, `ShowHiddenHandles` is `off`, which means MATLAB obeys the setting of the `HandleVisibility` property. When set to `on`, all handles are visible from the command line and within callback routines. This can be useful when you want access to all graphics objects that exist at a given time, including the handles of axes text labels, which are normally hidden.

The `close` function also allows access to nonvisible figures using the `hidden` option. For example,

```
close('hidden')
```

closes the topmost figure on the screen, even if it is protected. Combining `all` and `hidden` options,

```
close('all','hidden')
```

closes all figures.

## The Close Request Function

MATLAB executes a callback routine defined by the figure's `CloseRequestFcn` whenever you:

- Issue a `close` command on a figure.
- Quit MATLAB while there are visible figures. (If a figure's `Visible` property is set to `off`, MATLAB does not execute its close request function when you quit MATLAB; the figure is just deleted).
- Close a figure from the windowing system using a close box or a close menu item.

The close request function enables you to prevent or delay the closing of a figure or the termination of a MATLAB session. This is useful to perform such actions as:

- Displaying a dialog box requiring the user to confirm the action.
- Saving data before closing.
- Preventing unintentional command-line deletion of a graphical user interface built with MATLAB.

The default callback routine for the `CloseRequestFcn` is an M-file called `closereq`. It contains the statements

```
shh=get(0,'ShowHiddenHandles');  
set(0,'ShowHiddenHandles','on');  
delete(get(0,'CurrentFigure'));  
set(0,'ShowHiddenHandles',shh);
```

This callback disables `HandleVisibility` control by setting the root `ShowHiddenHandles` property to `on`, which makes all figure handles visible.

### Quitting MATLAB

When you quit MATLAB, the current figure's `CloseRequestFcn` is called, and if the figure is deleted, the next figure in the root's list of children (i.e., the root's `Children` property) becomes the current figure, and its `CloseRequestFcn` is in turn executed, and so on. You can, therefore, use `gcf` to specify the figure handle from within the close request function.

If you change a figure's `CloseRequestFcn` so that it does not delete the figure (e.g., defining this property as an empty string), then issuing the close command on that figure does not cause it to be deleted. Furthermore, if you attempt to quit MATLAB, the quit is aborted because MATLAB does not delete the figure.

### Errors in the Close Request Function

If the `CloseRequestFcn` generates an error when executed, MATLAB aborts the close operation. However, errors in the `CloseRequestFcn` do not abort attempts to quit MATLAB. If an error occurs in a figure's `CloseRequestFcn`, MATLAB closes the figure unconditionally following a quit or exit command.

### Overriding the Close Request Function

The `delete` command always deletes the specified figure, regardless of the value of its `CloseRequestFcn`. For example, the statement,

```
delete(get(0, 'Children'))
```

deletes all figures whose handles are not hidden (i.e., the `HandleVisibility` property is set to `off`). If you want to delete all figures regardless of whether their handles are hidden, you can set the root `ShowHiddenHandles` property to `on`. The root `Children` property then contains the handles of all figures. For example, the statements,

```
set(0, 'ShowHiddenHandles', 'yes')
delete(get(0, 'Children'))
```

unconditionally delete all figures.

### Handle Validity Versus Handle Visibility

All handles remain valid regardless of whether they are visible or not. If you know an object's handle, you can set and get its properties. By default, figure handles are integers that are displayed at the top of the window.

**You can provide further protection to figures by setting the `IntegerHandle` property to `off`. MATLAB then uses a floating-point number for figure handles.**

## Saving Handles in M-Files

Graphics M-files frequently use handles to access property values and to direct graphics output to a particular target. MATLAB provides utility routines that return the handles to key objects (such as the current figure and axes). In M-files, however, these utilities may not be the best way to obtain handles because:

- Querying MATLAB for the handle of an object or other information is less efficient than storing the handle in a variable and referencing that variable.
- The current figure, axes, or object may change during M-file execution because of user interaction.

### Save Information First

It is a good practice to save relevant information about MATLAB's state in the beginning of your M-file. For example, you can begin an M-file with

```
cax = newplot;  
cfig = get(cax, 'Parent');  
hold_state = ishold;
```

rather than querying this information each time you need it. Remember that utility commands like `ishold` obtain the values they return whenever called. (The `ishold` command issues a number of `get` commands and string compares (`strcmp`) to determine the hold state.)

If you are temporarily going to alter the hold state within the M-file, you should save the current values of the `NextPlot` properties so you can reset them later.

```
ax_nextplot = lower(get(cax, 'NextPlot'));  
fig_nextplot = lower(get(cfig, 'NextPlot'));  
.  
.  
.  
set(cax, 'NextPlot', ax_nextplot)  
set(cfig, 'NextPlot', fig_nextplot)
```

## Properties Changed by Built-In Functions

To achieve their intended effect, many built-in functions change axes properties, which can then affect the workings of your M-file. This table lists MATLAB's built-in graphics functions and the properties they change. Note that these properties change only if `hold` is off.

Function	Axes Property: Set To
<code>fill</code>	Box: on CameraPosition: 2-D view CameraTarget: 2-D view CameraUpVector: 2-D view CameraViewAngle: 2-D view
<code>fill3</code>	CameraPosition: 3-D view CameraTarget: 3-D view CameraUpVector: 3-D view CameraViewAngle: 3-D view XScale: linear YScale: linear ZScale: linear
<code>image (high-level)</code>	Box: on Layer: top CameraPosition: 2-D view CameraTarget: 2-D view CameraUpVector: 2-D view CameraViewAngle: 2-D view XDir: normal XLim: [0 size(CData,1)]+0.5 XLimMode: manual YDir: reverse YLim: [0 size(CData,2)]+0.5 YLimMode: manual
<code>loglog</code>	Box: on CameraPosition: 2-D view CameraTarget: 2-D view CameraUpVector: 2-D view CameraViewAngle: 2-D view XScale: log YScale: log

<b>Function</b>	<b>Axes Property: Set To</b>
plot	Box: on CameraPosition: 2-D view CameraTarget: 2-D view CameraUpVector: 2-D view CameraViewAngle: 2-D view
plot3	CameraPosition: 3-D view CameraTarget: 3-D view CameraUpVector: 3-D view CameraViewAngle: 3-D view XScale: linear YScale: linear ZScale: linear
semilogx	Box: on CameraPosition: 2-D view CameraTarget: 2-D view CameraUpVector: 2-D view CameraViewAngle: 2-D view XScale: log YScale: linear
semilogy	Box: on CameraPosition: 2-D view CameraTarget: 2-D view CameraUpVector: 2-D view CameraViewAngle: 2-D view XScale: linear YScale: log



# Axes Properties

---

<b>Overview</b> . . . . .	8-2
<b>Labeling and Appearance Properties</b> . . . . .	8-3
Creating Axes with Specific Characteristics . . . . .	8-3
<b>Positioning Axes</b> . . . . .	8-5
The Position Vector . . . . .	8-5
Units . . . . .	8-6
<b>Multiple Axes per Figure</b> . . . . .	8-7
Placing Text Outside the Axes . . . . .	8-7
Multiple Axes for Different Scaling . . . . .	8-8
<b>Individual Axis Control</b> . . . . .	8-10
Setting Axis Limits . . . . .	8-11
Setting Tick Mark Locations . . . . .	8-12
Changing Axis Direction . . . . .	8-13
<b>Using Multiple X and Y Axes</b> . . . . .	8-16
Example – Double Axis Graphs . . . . .	8-16
<b>Automatic-Mode Properties</b> . . . . .	8-19
<b>Colors Controlled by Axes</b> . . . . .	8-22
Specifying Axes Colors . . . . .	8-22
Axes Color Limits – The CLim Property . . . . .	8-25
Example – Simulating Multiple Colormaps in a Figure . . . . .	8-25
Calculating Color Limits . . . . .	8-26
Defining the Color of Lines for Plotting . . . . .	8-29
Line Styles Used for Plotting –LineStyleOrder . . . . .	8-31

## Axes Topics

Axes are the parents of image, light, line, patch, rectangle, surface, and text graphics objects. These objects are the entities used to draw graphs of numerical data and pictures of real-world objects, such as airplanes or automobiles. Axes orient and scale their child objects to produce a particular effect, such as scaling a plot to accentuate certain information or rotating objects through various views.

Axes properties control many aspects of how MATLAB displays graphical information. This section discusses some of the features that are implemented through axes properties and provides examples of how to use these features.

The table in the axes reference page listing all axes properties provides an overview of the characteristics affected by these properties.

The topics covered in this section include:

- Labeling and Appearance Properties – properties that affect general appearance of the axes.
- Positioning Axes – how axes are positioned within a figure.
- Multiple Axes per Figure – how to use axes to place text outside the graph axes and how to use multiple axes within a figure to achieve different views.
- Individual Axis Control and Using Multiple X and Y Axes – properties that control the x-, y-, and z-axis individually.
- Automatic-Mode Properties – properties that are set automatically with each graph.
- Colors Controlled by Axes – covers axes colors and using color limits to control the mapping of data to colormaps.

## Labeling and Appearance Properties

MATLAB provides a number of properties for labeling and controlling the appearance of axes. For example, this surface plot shows some of the labeling possibilities and indicates the controlling property.

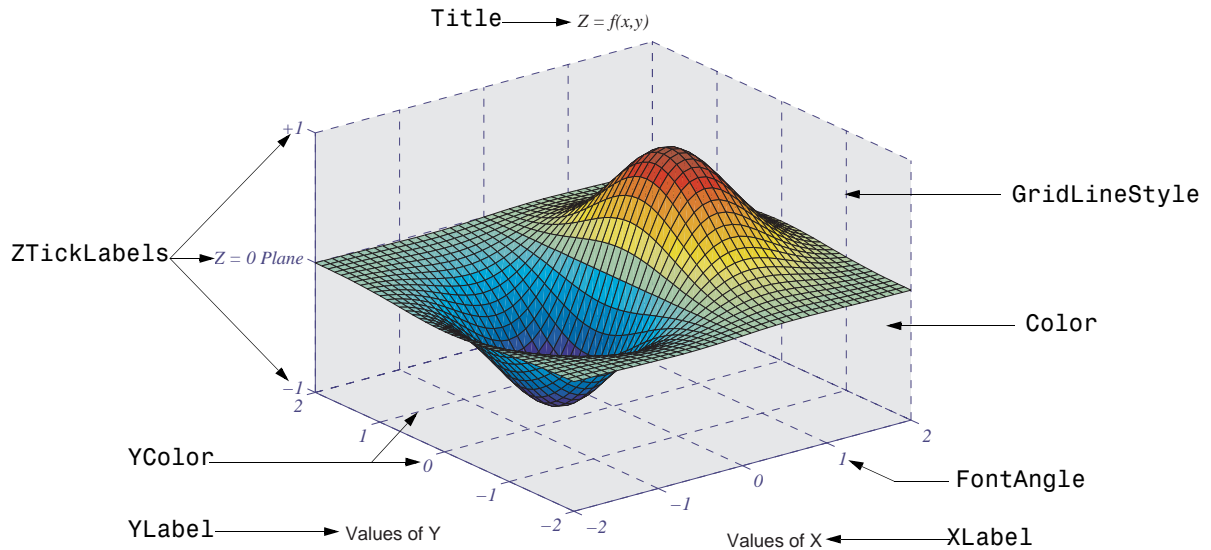

### Creating Axes with Specific Characteristics

To create this axes, specify values for the indicated properties.

```
h = axes('Color',[.9 .9 .9],...
        'GridLineStyle','--',...
        'ZTickLabels','-1|Z = 0 Plane|+1',...
        'FontName','times',...
        'FontAngle','italic',...
        'FontSize',14,...
        'XColor',[0 0 .7],...
        'YColor',[0 0 .7],...
        'ZColor',[0 0 .7]);
```

### Axis Labels

The individual axis labels are text objects whose handles are normally hidden from the command line (their `HandleVisibility` property is set to `callback`). You can use the `xlabel`, `ylabel`, `zlabel`, and `title` functions to create axis labels. However, these functions affect only the current axes. If you are labeling axes other than the current axes by referencing the axes handle, then you must obtain the text object handle from the corresponding axes property. For example,

```
get(axes_handle, 'XLabel')
```

returns the handle of the text object used as the  $x$ -axis label. Obtaining the text handle from the axes is useful in M-files and MATLAB-based applications where you cannot be sure the intended target is the current axes.

The following statements define the  $x$ - and  $y$ -axis labels and title for the axes above.

```
set(get(axes_handle, 'XLabel'), 'String', 'Values of X')
set(get(axes_handle, 'YLabel'), 'String', 'Values of Y')
set(get(axes_handle, 'Title'), 'String', '\fontname{times}\itZ =
f(x,y)')
```

Since the labels are text, you must specify a value for the `String` property, which is initially set to the empty string (i.e., there are no labels).

MATLAB overrides many of the other text properties to control positioning and orientation of these labels. However, you can set the `Color`, `FontAngle`, `FontName`, `FontSize`, `FontWeight`, and `String` properties.

Note that both axes objects and text objects have font specification properties. The call to the axes function on the previous page set values for the `FontName`, `FontAngle`, and `FontSize` properties. If you want to use the same font for the labels and title, specify these same property values when defining their `String` property. For example, the  $x$ -axis label statement would be

```
set(get(h, 'XLabel'), 'String', 'Values of X', ...
    'FontName', 'times', ...
    'FontAngle', 'italic', ...
    'FontSize', 14)
```

## Positioning Axes

The axes `Position` property controls the size and location of an axes within a figure. The default axes has the same aspect ratio (ratio of width to height) as the default figure and fills most of the figure, leaving a border around the edges. However, you can define the axes position as any rectangle and place it wherever you want within a figure.

### The Position Vector

MATLAB defines the axes `Position` property as a vector.

```
[left bottom width height]
```

`left` and `bottom` define a point in the figure that locates the lower-left corner of the axes rectangle. `width` and `height` specify the dimensions the axes rectangle. Viewing the axes in 2-D (azimuth =  $0^\circ$ , elevation =  $90^\circ$ ) orients the  $x$ -axis horizontally and the  $y$ -axis vertically. From this angle, the plot box (the area used for plotting, exclusive of the axis labels) coincides with the axes rectangle.

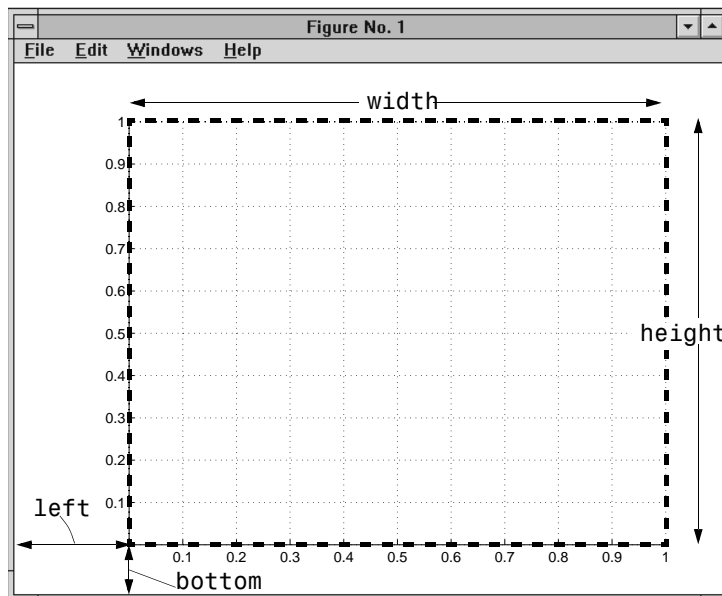

The default 3-D view is azimuth =  $-37.5^\circ$ , elevation =  $30^\circ$ .

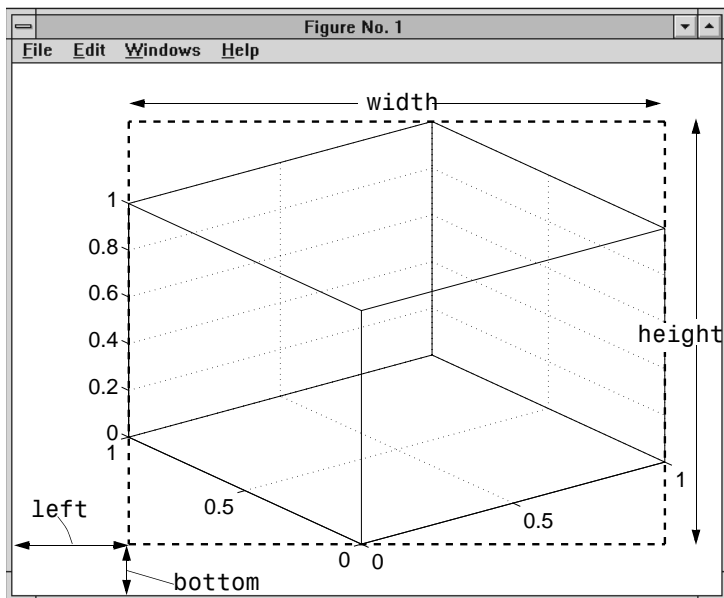

By default, MATLAB draws the plot box to fill the axes rectangle, regardless of its shape. However, axes properties enable control over the shape and scaling of the plot box.

## Units

The axes Units property determines the units of measurement for the Position property. Possible values for this property are

```
set(gca,'Units')
[ inches | centimeters | {normalized} | points | pixels ]
```

with normalized being the default. Normalized units map the lower-left corner of the figure to the point (0,0) and the upper-right corner to (1.0,1.0), regardless of the size of the figure. Normalized units cause axes to resize automatically whenever you resize the figure. All other units are absolute measurements that remained fixed as you resize the figure.

## Multiple Axes per Figure

The `subplot` function creates multiple axes in one figure by computing values for `Position` that produce the specified number of axes.

The `subplot` function is useful for laying out a number of graphs equally spaced in the figure. However, overlapping axes can create some other useful effects.

### Placing Text Outside the Axes

MATLAB always displays text objects within an axes. If you want to create a graph and provide a description of the information alongside the graph, you must create another axes to position the text. If you create an axes that is the same size as the figure and then create a smaller axes to draw the graph, you can then display text anywhere independently of the graph.

For example, define two axes.

```
h = axes('Position',[0 0 1 1], 'Visible','off');
axes('Position',[.25 .1 .7 .8])
```

Since the axes units are normalized to the figure, specifying the `Position` as `[0 0 1 1]` creates an axes that encompasses the entire window.

Now plot some data in the current axes. The last axes created is the current axes so MATLAB directs graphics output there.

```
t = 0:900;
plot(t,0.25*exp(-0.005*t))
```

Define the text and display it in the full-window axes.

```
str(1) = {'Plot of the function:'};
str(2) = {' y = A{\ite}^{\-alpha{\itt}}'};
str(3) = {'With the values:'};
str(3) = {' A = 0.25'};
str(4) = {' \alpha = .005'};
str(5) = {' t = 0:900'};
set(gcf,'CurrentAxes',h)
text(.025,.6,str,'FontSize',12)
```

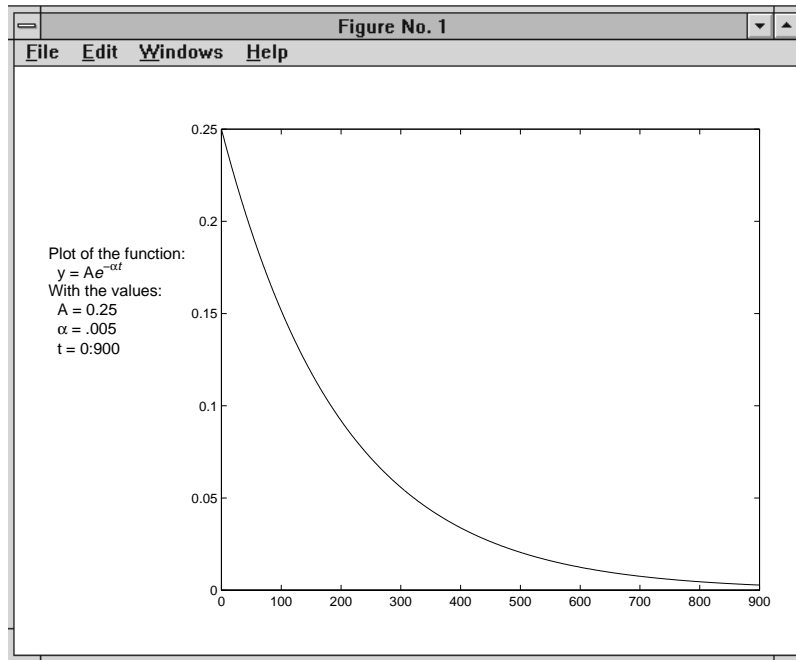

## Multiple Axes for Different Scaling

You can create multiple axes to display graphics objects with different scaling without changing the data that defines these objects (which would be required to display them in a single axes).

```
h(1) = axes('Position',[0 0 1 1]);  
sphere  
h(2) = axes('Position',[0 0 .4 .6]);  
sphere  
h(3) = axes('Position',[0 .5 .5 .5]);  
sphere  
h(4) = axes('Position',[.5 0 .4 .4]);  
sphere  
h(5) = axes('Position',[.5 .5 .5 .3]);  
sphere  
set(h,'Visible','off')
```



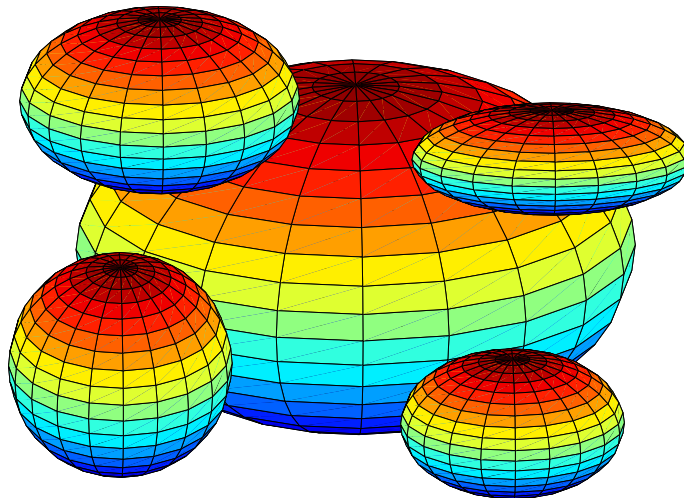

Each sphere is defined by the same data. However, since the parent axes occupy regions of different size and location, the spheres appear to be different sizes and shapes.

## Individual Axis Control

MATLAB automatically determines axis limits, tick mark placement, and tick mark labels whenever you create a graph. However, you can specify these values manually by setting the appropriate property.

When you specify a value for a property controlled by a mode (e.g., the `XLim` property has an associated `XLimMode` property), MATLAB sets the mode to manual enabling you to override automatic specification. Since the default values for these mode properties are automatic, calling high-level functions such as `plot` or `surf` resets these modes to `auto`.

This section discusses the following properties.

Property	Purpose
<code>XLim</code> , <code>YLim</code> , <code>ZLim</code>	Sets the axis range.
<code>XLimMode</code> , <code>YLimMode</code> , <code>ZLimMode</code>	Specifies whether axis limits are determined automatically by MATLAB or specified manually by the user.
<code>XTick</code> , <code>YTick</code> , <code>ZTick</code>	Sets the location of the tick marks along the axis.
<code>XTickMode</code> , <code>YTickMode</code> , <code>ZTickMode</code>	Specifies whether tick mark locations are determined automatically by MATLAB or specified manually by the user.
<code>XTickLabel</code> , <code>YTickLabel</code> , <code>ZTickLabel</code>	Specifies the labels for the axis tick marks.
<code>XTickLabelMode</code> , <code>YTickLabelMode</code> , <code>ZTickLabelMode</code>	Specifies whether tick mark labels are determined automatically by MATLAB or specified manually by the user.
<code>XDir</code> , <code>YDir</code> , <code>ZDir</code>	Sets the direction of increasing axis values.

## Setting Axis Limits

MATLAB determines the limits automatically for each axis based on the range of the data. You can override the selected limits by specifying the `XLim`, `YLim`, or `ZLim` property. For example, consider a plot of the function  $Ae^{-\alpha t}$  evaluated with  $A = 0.25$ ,  $\alpha = 0.05$ , and  $t = 0$  to  $900$ .

```
t = 0:900;
plot(t,0.25*exp(-0.05*t))
```

The plot on the left shows the results. MATLAB selects axis limits that encompass the range of data in both  $x$  and  $y$ . However, since the plot contains little information beyond  $t = 100$ , changing the  $x$ -axis limits improves the usefulness of the plot. If the handle of the axes is `axes_handle`, then following statement,

```
set(axes_handle,'XLim',[0 100])
```

creates the plot on the right.

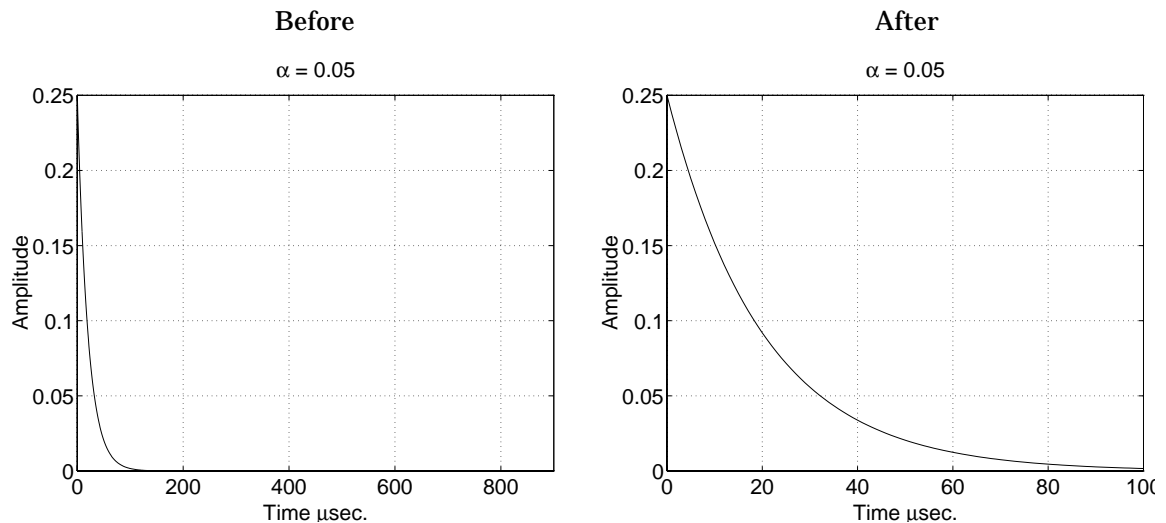

You can use the `axis` command to set limits on the current axes only.

### Semiautomatic Limits

You can specify either the minimum or maximum value for an axis limit and allow the other limit to autorange. Do this by setting an explicit value for the manual limit and `Inf` for the automatic limit. For example, the statement,

```
set(axes_handle, 'XLim', [0 Inf])
```

sets the `XLimMode` property to `auto` and allows MATLAB to determine the maximum value for `XLim`. Similarly, the statement,

```
set(axes_handle, 'XLim', [-Inf 800])
```

sets the `XLimMode` property to `auto` and allows MATLAB to determine the minimum value for `XLim`.

### Setting Tick Mark Locations

MATLAB selects the tick mark location based on the data range to produce equally spaced ticks (for linear graphs). You can specify alternative locations for the tick marks by setting the `XTick`, `YTick`, and `ZTick` properties.

For example, if the value 0.075 is of interest for the amplitude of the function  $Ae^{-\alpha t}$ , specify tick marks to include that value.

```
set(gca, 'YTick', [0 0.05 0.075 0.1 0.15 0.2 0.25])
```

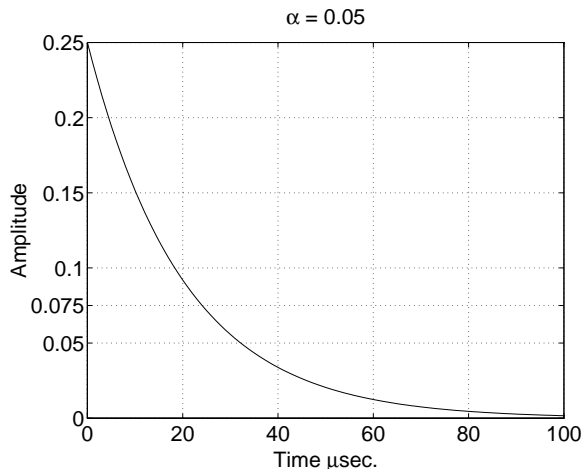

You can change tick labeling from numbers to strings using the `XTickLabel`, `YTickLabel`, and `ZTickLabel` properties.

For example, to label the  $y$ -axis value of 0.075 with the string `Cutoff`, you can specify all  $y$ -axis labels as a string, separating each label with the “|” character.

```
set(gca, 'YTickLabel', '0|0.05|Cutoff|0.1|0.15|0.2|0.25')
```

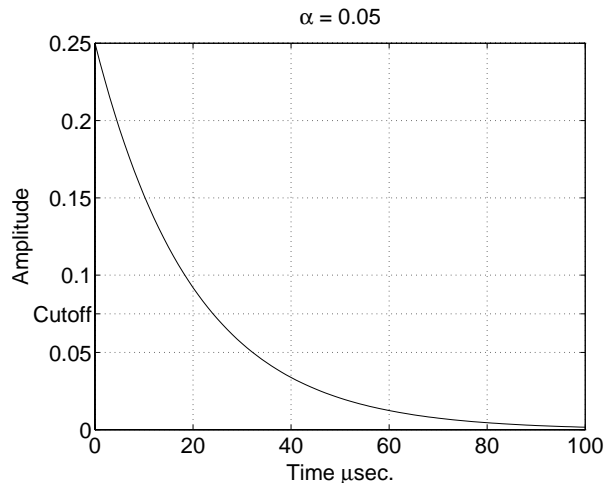

## Changing Axis Direction

The `XDir`, `YDir`, and `ZDir` properties control the direction of increasing values on the respective axis. In the default 2-D view, the  $x$ -axis values increase from left to right and the  $y$ -axis values increase from bottom to top. The  $z$ -axis points out of the screen.

You can change the direction of increasing values by setting the associated property to reverse. For example, setting `XDir` to reverse,

```
set(gca, 'XDir', 'reverse')
```

produces a plot whose  $x$ -axis decreases from left to right.

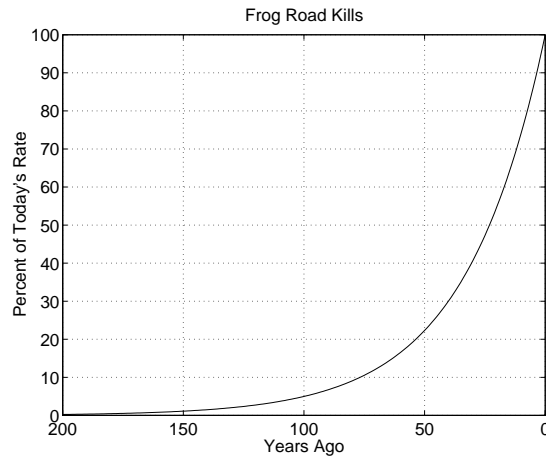

In the 3-D view, the  $y$ -axis increases from front to back and the  $z$ -axis increases from bottom to top.

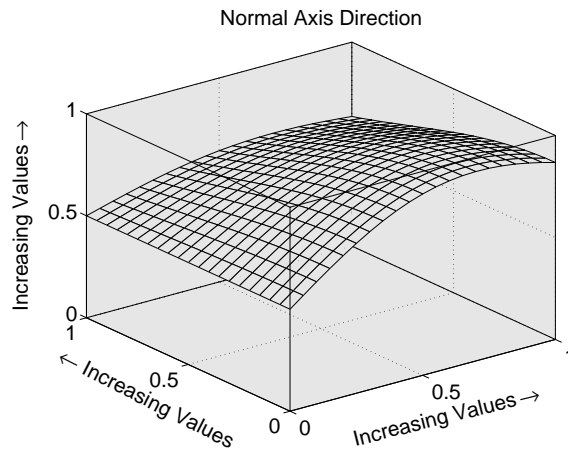

Setting the  $x$ -,  $y$ -, and  $z$ -directions to reverse,

```
set(gca, 'XDir', 'rev', 'YDir', 'rev', 'ZDir', 'rev')
```

yields

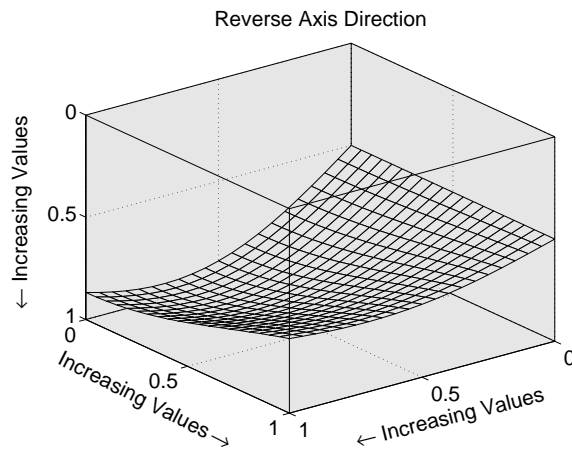

## Using Multiple X and Y Axes

The `XAxisLocation` and `YAxisLocation` properties specify on which side of the graph to place the  $x$ - and  $y$ -axes. You can create graphs with two different  $x$ -axes and  $y$ -axes by superimposing two axes objects and using `XAxisLocation` and `YAxisLocation` to position each axis on a different side of the graph. This technique is useful to plot different sets of data with different scaling in the same graph.

### Example – Double Axis Graphs

This example creates a graph to display two separate sets of data using the bottom and left sides as the  $x$ - and  $y$ -axis for one, and the top and right sides as the  $x$ - and  $y$ -axis for the other.

Using low-level `line` and axes routines allows you to superimpose objects easily. Plot the first data, making the color of the line and the corresponding  $x$ - and  $y$ -axis the same to more easily associate them.

```
h11 = line(x1,y1,'Color','r');
ax1 = gca;
set(ax1,'XColor','r','YColor','r')
```

Next, create another axes at the same location as the first, placing the  $x$ -axis on top and the  $y$ -axis on the right. Set the axes `Color` to `none` to allow the first axes to be visible and color code the  $x$ - and  $y$ -axis to match the data.

```
ax2 = axes('Position',get(ax1,'Position'),...
          'XAxisLocation','top',...
          'YAxisLocation','right',...
          'Color','none',...
          'XColor','k','YColor','k');
```

Draw the second set of data in the same color as the  $x$ - and  $y$ -axis.

```
h12 = line(x2,y2,'Color','k','Parent',ax2);
```



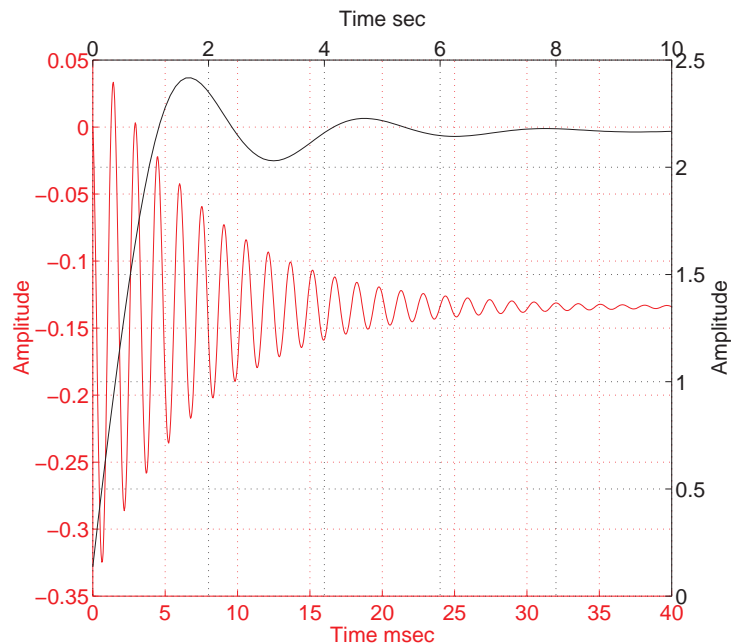

### Creating Coincident Grids

Since the two axes are completely independent, MATLAB determines tick mark locations according to the data plotted in each. It is unlikely the gridlines will coincide. This produces a somewhat confusing looking graph, even though the two grids are drawn in different colors. However, if you manually specify tick mark locations, you can make the grids coincide.

The key is to specify the same number of tick marks along corresponding axis lines (it is also necessary for both axes to be the same size). The following graph of the same data uses six tick marks per axis, equally spaced within the original limits. To calculate the tick mark location, obtain the limits of each axis and calculate an increment.

```
xlimits = get(ax1,'XLim');
ylimits = get(ax1,'YLim');
xinc = (xlimits(2)-xlimits(1))/5;
yinc = (ylimits(2)-ylimits(1))/5;
```

Now set the tick mark locations.

```
set(ax1, 'XTick', [xlims(1):xinc:xlims(2)], ...  
      'YTick', [ylims(1):yinc:ylims(2)])
```

The resulting graph is visually simpler, even though the  $y$ -axis on the left has rather odd tick mark values.

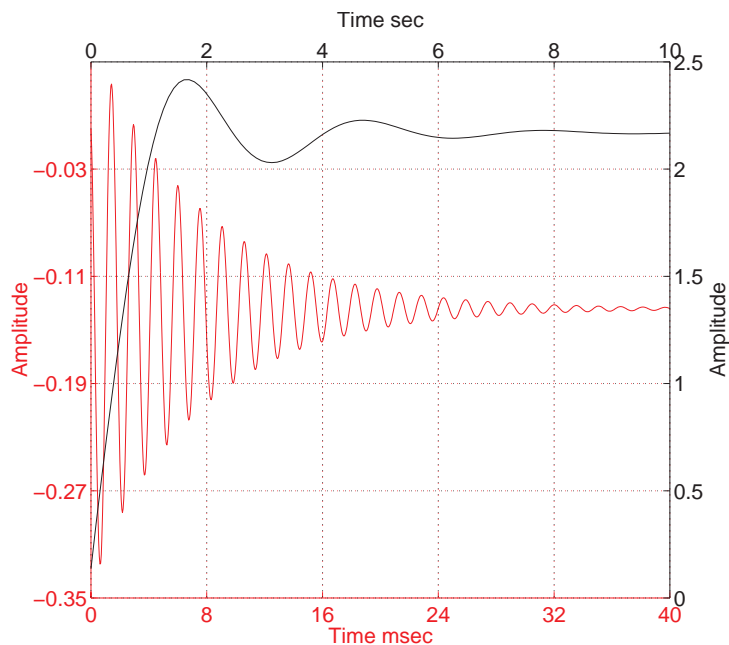

## Automatic-Mode Properties

While object creation routines that create axes children do not explicitly change axes properties, some axes properties are under automatic control when their associated mode property is set to auto (which is the default). The following table lists the automatic-mode properties.

Mode Properties	What It Controls
CameraPositionMode	Positioning of the viewpoint
CameraTargetMode	Positioning of the camera target in the axes
CameraUpVectorMode	The direction of “up” in 2-D and 3-D views
CameraViewAngleMode	The size of the projected scene and stretch-to-fit behavior
CLimMode	Mapping of data values to colors
DataAspectRatioMode	Relative scaling of data units along $x$ , $y$ , and $z$ axes and stretch-to-fit behavior
PlotBoxAspectRatioMode	Relative scaling of plot box along $x$ , $y$ , and $z$ axes and stretch-to-fit behavior
TickDirMode	Direction of axis tick marks (in for 2-D, out for 3-D)
XLimMode YLimMode ZLimMode	Limits of the respective $x$ , $y$ , and $z$ axes
XTickMode YTickMode ZTickMode	Tick mark spacing along the respective $x$ , $y$ , and $z$ axes
XTickLabelMode YTickLabelMode ZTickLabelMode	Tick mark labels along the respective $x$ , $y$ , and $z$ axes

For example, if all property values are set to their defaults and you enter these statements

```
line(1:10,1:10)
line(1:10,[1:10].^2)
```

the second line statement causes the `YLim` property to change from `[0 10]` to `[0 100]`.

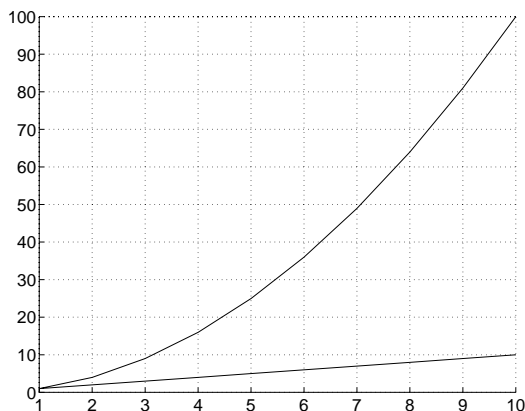

This is because `YLimMode` is `auto`, which always causes MATLAB to recompute the axis limits.

If you set the value controlled by an automatic-mode property, MATLAB sets the mode to `manual` and does not automatically recompute the value.

For example, in the statements

```
line(1:10,1:10)
set(gca,'XLim',[1 10],'YLim',[1 20])
line(1:10,[1:10].^2)
```

the `set` statement sets the  $x$ - and  $y$ -axis limits *and* changes the `XLimMode` and `YLimMode` properties to `manual`. The second line statement now draws a line that is clipped to the axis limits `[1 12]` instead of causing the axes to recompute its limits.

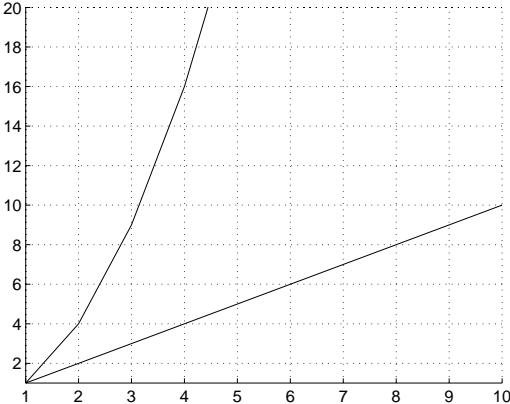

## Colors Controlled by Axes

Axes properties specify the color of the axis lines, tick marks, labels, and the background. Properties also control the color of the lines drawn by plotting routines and how image, patch, and surface objects obtain colors from the figure colormap.

The axes properties discussed in this section are listed in the following table.

Property	Characteristic it Controls
Color	Axes background color
XColor, YColor, ZColor	Color of the axis lines, tick marks, gridlines and labels
Title	Title text object handles
XLabel, YLabel, Zlabel	Axis label text object handles
CLim	Controls mapping of graphic object CData to the figure colormap
CLimMode	Automatic or manual control of CLim property
ColorOrder	Line color autcycle order
LineStyleOrder	Line styles autcycle order (not a color, but related to ColorOrder)

### Specifying Axes Colors

The default axes background color is set up by the `colordef` command, which is called in your startup file. However, you can easily define your own color scheme.

See `InvertHardCopy` for information on how MATLAB automatically changes the color scheme for printing hardcopy.

## Changing the Color Scheme

Suppose you want an axes to use a “black-on-white” color scheme. First, change the background to white and the axis lines, grid, tick marks, and tick mark labels to black.

```
set(gca, 'Color', 'w', ...  
        'XColor', 'k', ...  
        'YColor', 'k', ...  
        'ZColor', 'k')
```

Next, change the color of the text objects used for the title and axis labels.

```
set(get(gca, 'Title'), 'Color', 'k')  
set(get(gca, 'XLabel'), 'Color', 'k')  
set(get(gca, 'YLabel'), 'Color', 'k')  
set(get(gca, 'ZLabel'), 'Color', 'k')
```

Changing the figure background color to white completes the new color scheme.

```
set(gcf, 'Color', 'w')
```

When you are done, a figure containing a mesh plot looks like the following figure.

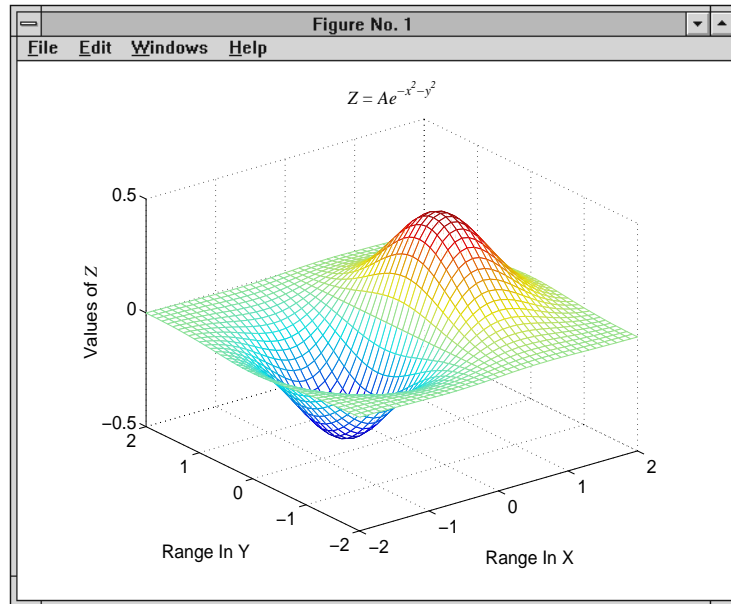

You can define default values for the appropriate properties and put these definitions in your `startup.m` file. Titles and axis labels are text objects, so you must set a default color for all text objects, which is a good idea anyway since the default text color of white is not visible on the white background. Lines created with the low-level `line` function (but not the plotting routines) also have a default color of white, so you should change the default line color as well.

To set default values on the root level, use.

```
set(0,'DefaultFigureColor','w'  
     'DefaultAxesColor','w',...  
     'DefaultAxesXColor','k',...  
     'DefaultAxesYColor','k',...  
     'DefaultAxesZColor','k',...  
     'DefaultTextColor','k',...  
     'DefaultLineColor','k')
```

MATLAB colors other axes children (i.e., image, patch, and surface objects) according to the values of their `CData` properties and the figure colormap.



## Axes Color Limits – The CLim Property

Many of the 3-D graphics functions produce graphs that use color as another data dimension. For example, surface plots map surface height to color. The color limits control the limits of the color dimension in a way analogous to setting axis limits.

The axes `CLim` property controls the mapping of image, patch, and surface `CData` to the figure colormap. `CLim` is a two-element vector [`cmin` `cmax`] specifying the `CData` value to map to the first color in the colormap (`cmin`) and the `CData` value to map the last color in the colormap (`cmax`). Data values in between are linearly transformed from the second to the next to last color, using the expression

```
colormap_index = fix((CData-cmin)/(cmax-cmin)*cm_length)+1
```

`cm_length` is the length of the colormap. When `CLimMode` is `auto`, MATLAB sets `CLim` to the range of the `CData` of all graphics objects within the axes. However, you can set `CLim` to span any range of values. This allows individual axes within a single figure to use different portions of the figure's colormap. You can create colormaps with different regions, each used by a different axes.

See the `caxis` command for more information on color limits

## Example – Simulating Multiple Colormaps in a Figure

Suppose you want to display two different surfaces in the same figure and color each surface with a different colormap. You can produce the effect of two different colormaps by concatenating two colormaps together and then setting the `CLim` property of each axes to map into a different portion of the colormap.

This example creates two surfaces from the same topographic data. One uses the color scheme of a typical atlas – shades of blue for the ocean and greens for the land. The other surface is illuminated with a light source to create the illusion of a three-dimensional picture. Such illumination requires a colormap that changes monotonically from dark to light.

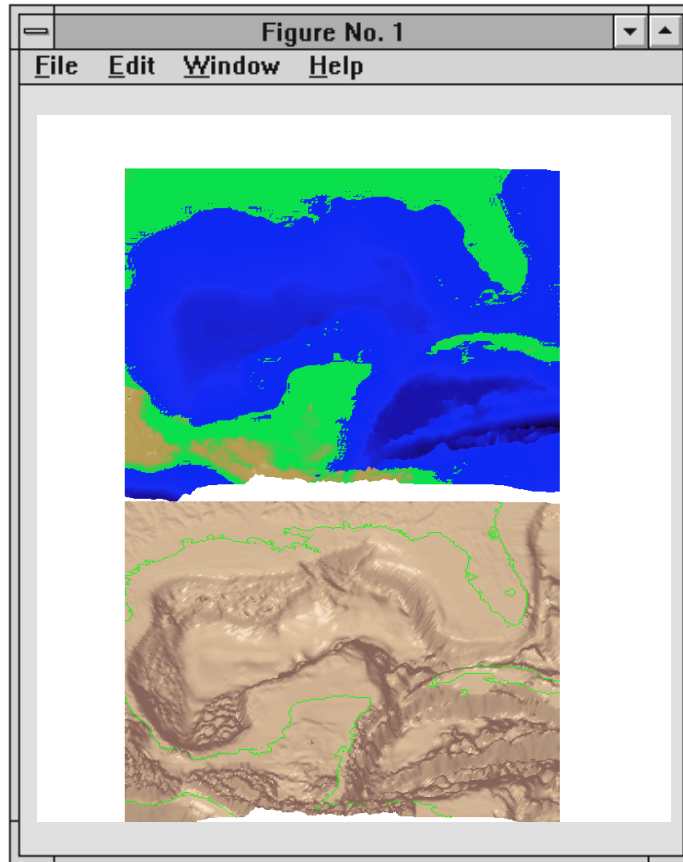

### Calculating Color Limits

The key to this example is calculating values for `CLim` that cause each surface to use the section of the colormap containing the appropriate colors.

To calculate the new values for `CLim`, you need to know:

- The total length of the colormap (`CmLength`)
- The beginning colormap slot to use for each axes (`BeginSlot`)
- The ending colormap slot to use for each axes (`EndSlot`)

- The minimum and maximum CData values of the graphic objects contained in the axes. That is, the values of the axes CLim property determined by MATLAB when CLimMode is auto (CDmin and CDmax).

First, define subplots regions, and plot the surfaces.

```
ax1 = subplot(2,1,1);
view([0 80])
surf(topodata)
shading interp
ax2 = subplot(2,1,2);
view([0 80]);
surf1(topodata,[60 0])
shading interp
```

Concatenate two colormaps together and install the new colormap.

```
colormap([Lightingmap;Atlasmap]);
```

Obtain the data you need to calculate new values for CLim.

```
CmLength = size(get(gcf,'Colormap'),1);% Colormap length
BeginSlot1 = 1; % Beginning slot
EndSlot1 = size(Lightingmap,1); % Ending slot
BeginSlot2 = EndSlot1+1;
EndSlot2 = CmLength;
CLim1 = get(ax1,'CLim');% CLim values for each axis
CLim2 = get(ax2,'CLim');
```

### Defining a Function to Calculate CLim Values

Computing new values for CLim involves determining the portion of the colormap you want each axes to use relative to the total colormap size and scaling its CLim range accordingly. You can define a MATLAB function to do this.

```
function CLim = newclim(BeginSlot,EndSlot,CDmin,CDmax,CmLength)
% Convert slot number and range
% to percent of colormap
PBeginSlot = (BeginSlot - 1) / (CmLength - 1);
PEndSlot = (EndSlot - 1) / (CmLength - 1);
PCmRange = PEndSlot - PBeginSlot;
% Determine range and min and max
```

```
%           of new CLim values
DataRange  = CDmax - CDmin;
ClimRange  = DataRange / PCmRange;
NewCmin    = CDmin - (PBeginSlot * ClimRange);
NewCmax    = CDmax + (1 - PEndSlot) * ClimRange;
CLim       = [NewCmin, NewCmax];
```

The input arguments are identified in the bulleted list above. The M-file first computes the percentage of the total colormap you want to use for a particular axes (PCmRange) and then computes the CLim range required to use that portion of the colormap given the CData range in the axes. Finally, it determines the minimum and maximum values required for the calculated CLim range and return these values. These values are the color limits for the given axes.

### Using the Function

Use the `newclim` M-file to set the CLim values of each axes. The statement,

```
set(ax1, 'CLim', newclim(65, 120, clim1(1), clim1(2)))
```

sets the CLim values for the first axes so the surface uses color slots 65 to 120. The lit surface uses the lower 64 slots. You need to reset its CLim values as well.

```
set(ax2, 'CLim', newclim(1, 64, clim1(1), clim1(2)))
```

### How the Function Works

MATLAB enables you to specify any values for the axes CLim property, even if these values do not correspond to the CData of the graphics objects displayed in the axes. MATLAB always maps the minimum CLim value to the first color in the colormap and the maximum CLim value to the last color in the colormap, whether or not there are really any CData values corresponding to these colors. Therefore, if you specify values for CLim that extend beyond the object's actual CData minimum and maximum, MATLAB colors the object with only a subset of the colormap.

The `newclim` M-file computes values for CLim that map the graphics object's actual CData values to the beginning and ending colormap slots you specify. It does this by defining a "virtual" graphics object having the computed CLim values. The following picture illustrates this concept. It shows a side view of two surfaces to make it easier to visualize the mapping of color to surface topography. The virtual surface is on the left and the actual surface on the right. In the center is the figure's colormap.

The real surface has `CLim` values of  $[0.4 \ -0.4]$ . To color this surface with slots 65 to 120, `newcmap` computed new `CLim` values of  $[0.4 \ -1.4269]$ . The virtual surface on the left represents these values.

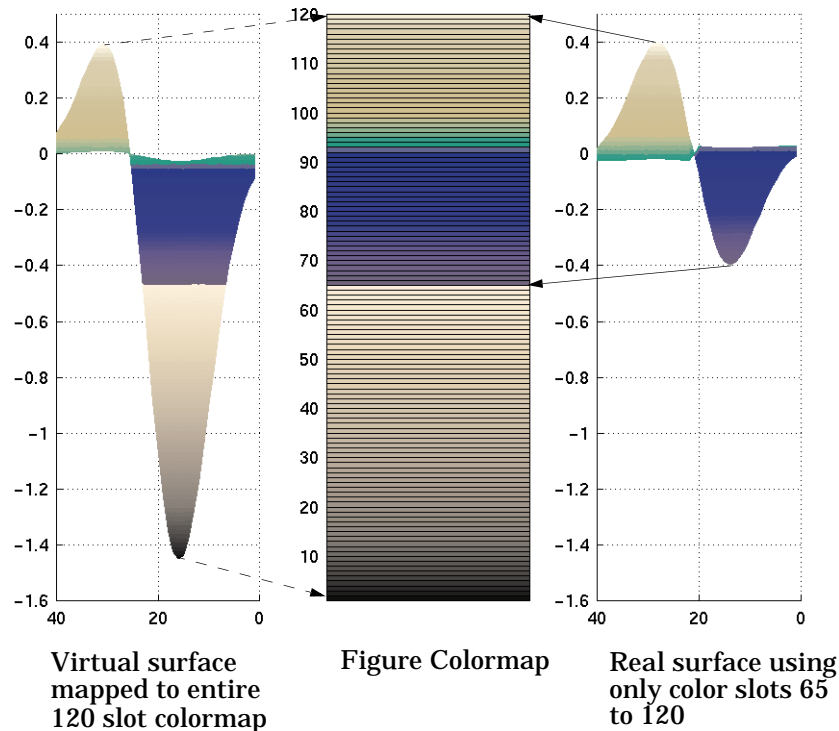

## Defining the Color of Lines for Plotting

The axes `ColorOrder` property determines the color of the individual lines drawn by the `plot` and `plot3` functions. For multiline graphs, these functions cycle through the colors defined by `ColorOrder`, repeating the cycle when reaching the end of the list.

The `colordef` command defines various color order schemes for different background colors. `colordef` is typically called in the `matlabrc` file, which is executed during MATLAB's startup.

### Defining Your Own ColorOrder

You can redefine `ColorOrder` to be any  $m$ -by-3 matrix of RGB values, where  $m$  is the number of colors. However, high-level functions like `plot` and `plot3` reset most axes properties (including `ColorOrder`) to the defaults each time you call them. To use your own `ColorOrder` definition you must take one of the following three steps:

- Define a default `ColorOrder` on the figure or root level, or
- Change the axes `NextPlot` property to add or replace children, or
- Use the informal form of the line function, which obeys the `ColorOrder` but does not clear the axes or reset properties

**Changing the Default ColorOrder.** You can define a new `ColorOrder` that MATLAB uses within a particular figure, for all axes within any figures created during the MATLAB session, or as a user-defined default that MATLAB always uses.

To change the `ColorOrder` for all plots in the current figure, set a default in that figure. For example, to set `ColorOrder` to the colors red, green, and blue, use the statement,

```
set(gcf, 'DefaultAxesColorOrder', [1 0 0; 0 1 0; 0 0 1])
```

To define a new `ColorOrder` that MATLAB uses for all plotting during your entire MATLAB session, set a default on the root level so axes created in any figure use your defaults.

```
set(0, 'DefaultAxesColorOrder', [1 0 0; 0 1 0; 0 0 1])
```

To define a new `ColorOrder` that MATLAB always uses, place the previous statement in your `startup.m` file.

**Setting the NextPlot Property.** The axes `NextPlot` property determines how high-level graphics functions draw into an existing axes. You can use this property to prevent `plot` and `plot3` from resetting the `ColorOrder` property each time you call them, but still clear the axes of any existing plots.

By default, `NextPlot` is set to `replace`, which is equivalent to a `cla reset` command (i.e., delete all axes children and reset all properties, except `Position`, to their defaults). If you set `NextPlot` to `replacechildren`,

```
set(gca, 'NextPlot', 'replacechildren')
```

MATLAB deletes the axes children, but does not reset axes properties. This is equivalent to a `cla` command without the `reset`.

After setting `NextPlot` to `replacechildren`, you can redefine the `ColorOrder` property and call `plot` and `plot3` without affecting the `ColorOrder`.

Setting `NextPlot` to `add` is the equivalent of issuing the `hold on` command. This setting prevents MATLAB from resetting the `ColorOrder` property, but it does not clear the axes children with each call to a plotting function.

**Using the line Function.** The behavior of the `line` function depends on its calling syntax. When you use the informal form (which does not include any explicit property definitions).

```
line(x,y,z)
```

`line` obeys the `ColorOrder` property, but does not clear the axes with each invocation or change the view to 3-D (as `plot3` does). However, `line` can be useful for creating your own plotting functions where you do not want the automatic behavior of `plot` or `plot3`, but you do want multiline graphs to use a particular `ColorOrder`.

## Line Styles Used for Plotting – `LineStyleOrder`

The axes `LineStyleOrder` property is analogous to the `ColorOrder` property. It specifies the line styles to use for multiline plots created with the `plot` and `plot3` functions. MATLAB increments the line style only after using all of the colors in the `ColorOrder` property. It then uses all the colors again with the second line style, and so on.

For example, define a default `ColorOrder` of red, green, and blue and a default `LineStyleOrder` of solid, dashed, and dotted lines.

```
set(0,'DefaultAxesColorOrder',[1 0 0;0 1 0;0 0 1],...
    'DefaultAxesLineStyleOrder','-|--|:')
```

Then plot some multiline data.

```
t = 0:pi/20:2*pi;
a = ones(length(t),9);
for i = 1:9
    a(:,i) = sin(t-i/5)';
end
plot(t,a)
```

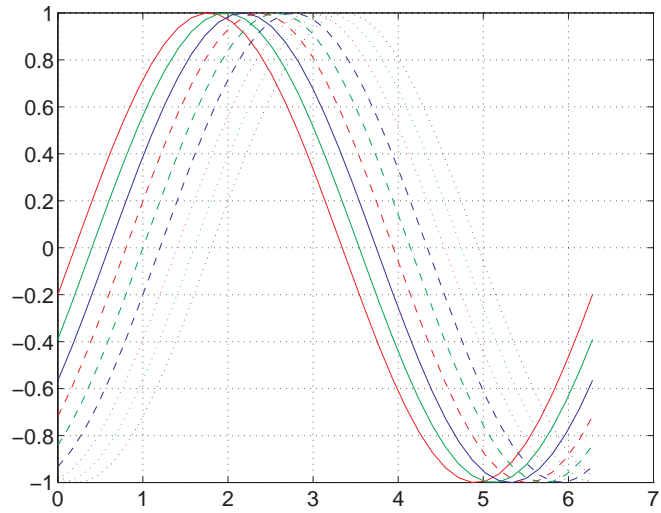

MATLAB cycles through all colors for each line style.



# Figure Properties

---

<b>Overview</b> . . . . .	9-2
<b>Positioning Figures</b> . . . . .	9-3
The Position Vector . . . . .	9-3
Example – Specifying Figure Position . . . . .	9-5
<b>Controlling How MATLAB Uses Color</b> . . . . .	9-7
Indexed Color Displays . . . . .	9-7
Colormap Colors and Fixed Colors . . . . .	9-8
Using a Large Number of Colors . . . . .	9-9
Nonactive Figures and Shared Colors . . . . .	9-11
Dithering Truecolor on Indexed Color Systems . . . . .	9-12
<b>Selecting Drawing Methods</b> . . . . .	9-15
Backing Store . . . . .	9-15
Double Buffering . . . . .	9-15
Selecting a Renderer . . . . .	9-16
<b>Specifying the Figure Pointer</b> . . . . .	9-18
Defining Custom Pointers . . . . .	9-19
<b>Interactive Graphics</b> . . . . .	9-23

## Figure Topics

Figure graphics objects are the windows in which MATLAB displays graphical output. Figure properties allow you to control many aspects of these windows, such as their size and position on the screen, the coloring of graphics objects displayed within them, and the scaling of printed pictures.

This section discusses some of the features that are implemented through figure properties and provides examples of how to use these features. The table in the `figure` reference page listing all properties provides an overview of the characteristics affected by figure properties. This section covers the following topics.

- **Positioning Figures** – properties used to position figures and how they are measured.
- **Controlling How MATLAB Uses Color** – properties that control how MATLAB uses system color resources.
- **Selecting a Drawing Method** – how to select rendering method and when to use double buffering and backing store.
- **Specifying the Figure Pointer** – describes how to select from predefined pointers or define customer pointers.

## Positioning Figures

The figure `Position` property controls the size and location of the figure window on the root screen. At startup, MATLAB determines the size of your computer screen and defines a default value for `Position`. This default creates figures about one-quarter of the screen's size and places them centered left to right and in the top half of the screen.

### The Position Vector

MATLAB defines the figure `Position` property as a vector.

```
[left bottom width height]
```

`left` and `bottom` define the position of the first addressable pixel in the lower-left corner of the window, specified with respect to the lower-left corner of the screen. `width` and `height` define the size of the interior of the window (i.e., exclusive of the window border).

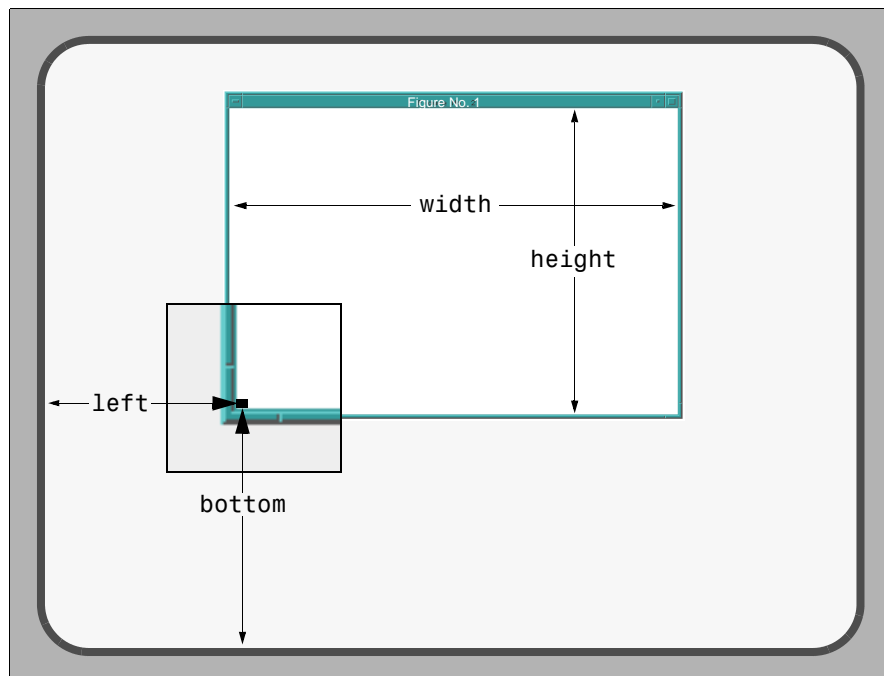

MATLAB does not measure the window border when placing the figure; the `Position` property defines only the internal active area of the figure window.

Since figures are windows under the control of your computer's windowing system, you can move and resize figures as you would any other windows. MATLAB automatically updates the `Position` property to the new values.

### Units

The figure's `Units` property determines the units of the values used to specify the position on the screen. Possible values for the `Units` property are

```
set(gcf, 'Units')  
[ inches | centimeters | normalized | points | {pixels} |  
characters]
```

with `pixels` being the default. These choices allow you to specify the figure size and location in absolute units (such as inches) if you want the window to always be a certain size, or in units relative to the screen size (such as pixels). `characters` are units that enable you to define the location and size of the figure in units that are based on the size of the default system font.

### Determining Screen Size

Whatever units you use, it is important to know the extent of the screen in those units. You can obtain this information from the root `ScreenSize` property. For example,

```
get(0, 'ScreenSize')  
ans =  
    1    1 1152  900
```

In this case, the screen is 1152 by 900 pixels. MATLAB returns the `ScreenSize` in the units determined by the root `Units` property. For example,

```
set(0, 'Units', 'normalized')
```

normalizes the values returned by `ScreenSize`.

```
get(0, 'ScreenSize')  
ans =  
    0    0    1    1
```

Defining the figure `Position` in terms of the `ScreenSize` in normalized units makes the specification independent of variations in screen size. This is useful if you are writing an M-file that is to be used on different computer systems.

## Example - Specifying Figure Position

Suppose you want to define two figure windows that occupy the upper third of the computer screen (e.g., one for uicontrols and the other to display data). To position the windows precisely, you must consider the window borders when calculating the size and offsets to specify for the `Position` properties.

The figure `Position` property does not include the window borders, so this example uses a width of 5 pixels on the sides and bottom and 30 pixels on the top.

```
bdwidth = 5;  
topbdwidth = 30;
```

Ensure root units are pixels and get the size of the screen

```
set(0, 'Units', 'pixels')  
scnsize = get(0, 'ScreenSize');
```

Define the size and location of the figures

```
pos1 = [bdwidth, ...  
        2/3*scnsize(4) + bdwidth, ...  
        scnsize(3)/2 - 2*bdwidth, ...  
        scnsize(4)/3 - (topbdwidth + bdwidth)];  
pos2 = [pos1(1) + scnsize(3)/2, ...  
        pos1(2), ...  
        pos1(3), ...  
        pos1(4)];
```

Create the figures

```
figure('Position', pos1)  
figure('Position', pos2)
```

The two figures now occupy the top third of the screen.

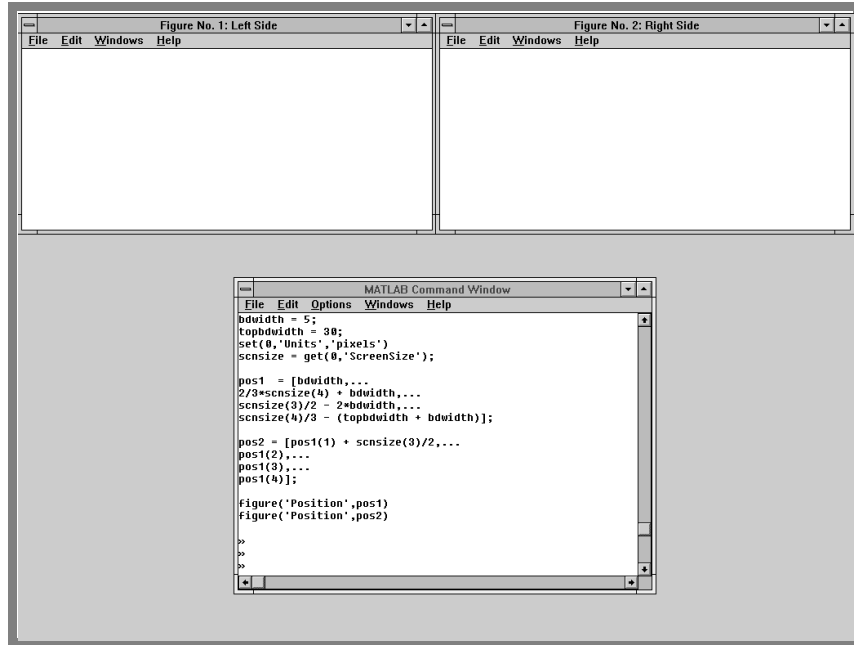

## Controlling How MATLAB Uses Color

Figure properties control the way MATLAB uses your computer's color resources. These properties influence both the speed of drawing and the accuracy of the colors used to display graphics. The properties discussed in this section include those listed in this table.

Property	Purpose
Colormap	The figure colormap. An $n$ -by-3 array of RGB values.
FixedColors	Specific colors used by the figure that are not in the colormap.
MinColormap	The minimum number of system color table slots MATLAB uses for the figure colormap.
ShareColors	The property that determines whether MATLAB shares colors with other figure colormaps in the system color table.
Dithermap	A predefined colormap for displaying truecolor graphics objects on a pseudocolor system.
DithermapMode	The property that determines whether MATLAB uses the current dither colormap or creates one based on the colors specified for existing graphics objects.

### Indexed Color Displays

MATLAB defines a unique colormap as well as fixed colors (which are not part of the colormap) for each figure object. Your computer system stores these color definitions in a color lookup table along with colors used for window borders, backgrounds, and so on.

Indexed color systems associate a color slot (as opposed to a specific color) in the system color table with each screen pixel. When you activate an application program, for example, by moving the focus to a MATLAB figure window, the system loads the colors associated with that program into the color table.

You can create a number of figures on the screen at once, but only one has focus at any given time. When you change the focus to a particular figure, the computer's operating system loads that figure's colormap and all its fixed colors into the system color table.

For example, the color table might be allocated like this.

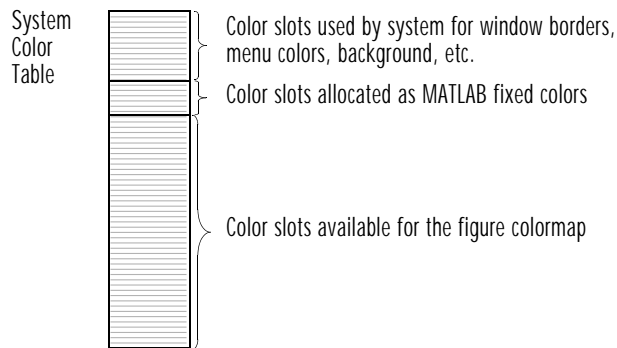

## Colormap Colors and Fixed Colors

MATLAB maintains two categories of colors for each figure – colors that are defined in the colormap and colors that are fixed, which do not change when you change the colormap. These two categories are used in different ways.

Only surface, patch, and image objects use the colormap. MATLAB colors these objects based on the order the colors appear in the colormap.

Fixed colors are simply definitions of specific colors that MATLAB uses to color axis lines and labels and values you specify for object colors (i.e., the `Color`, `ColorOrder`, `FaceColor`, `EdgeColor`, `MarkerFaceColor`, and `MarkerEdgeColor` properties).

### Defining Fixed Colors

When MATLAB creates a figure, it defines three fixed colors.

```
figure
get(gcf, 'FixedColors')
ans =
    0.8000    0.8000    0.8000
         0         0         0
```



```
1.0000    1.0000    1.0000
```

Creating an axes includes the colors defined by the axes `ColorOrder` property in the fixed color list, since it is more efficient to predefine these colors.

```
axes
get(gcf, 'FixedColors')
ans =
    0.8000    0.8000    0.8000
         0         0         0
    1.0000    1.0000    1.0000
         0         0    1.0000
         0    0.5000         0
    1.0000         0         0
         0    0.7500    0.7500
    0.7500         0    0.7500
    0.7500    0.7500         0
    0.2500    0.2500    0.2500
```

Any colors you define, for example,

```
set(surf_handle, 'EdgeColor', [.2 .8 .7])
```

also become part of the fixed color list. You can define as many fixed colors as you want without affecting the colors in the figure colormap. However, fixed colors occupy color table slots that MATLAB cannot use for the colormap.

## Using a Large Number of Colors

### Overview

Set `MinColormap` to a number equal to the size of your colormap when you do not want MATLAB to approximate colors. However, this may cause nonactive windows to display with incorrect colors.

### More Details

Problems can arise when you define a large colormap and/or a large number of fixed colors. If the number of color slots required exceeds the number available in the system color table, MATLAB specifies all fixed colors first, then linearly subsamples the colormap to fill the remaining slots.

For example, if the original colormap contains 128 colors and there are only 64 slots available, then MATLAB adds every other color to the color table. MATLAB maps each color in the original colormap to the color in the subsampled colormap that most closely matches the original color.

### Specifying the Minimum Colormap Size – `MinColormap`

The figure `MinColormap` property specifies the minimum number of slots in the system color table that MATLAB uses for the figure colormap. This enables you to use colormaps of any size up to the value of `MinColormap` and ensure MATLAB does not subsample the colors.

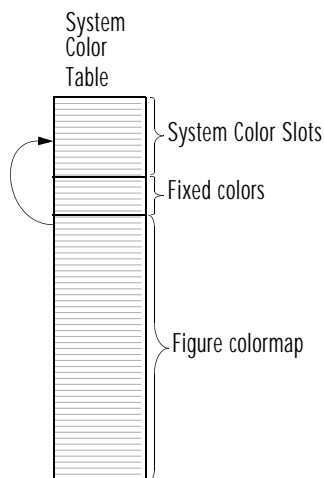

If you specify a value that is greater than the number of available slots, MATLAB takes over slots used to define system colors (on computers that allow overwriting of these colors). When this happens, nonactive windows can display with incorrect colors because MATLAB changed the color of the slot assigned to their pixels.

MATLAB does not take over color slots allocated to fixed colors. Therefore, limiting the number of fixed colors maximizes the number of colors allocated to the colormap. You can limit the number of fixed colors by specifying all noncolormap object colors (e.g., text, line, and figure colors) as the same color, and setting the axes `ColorOrder` property to just one color (the default is seven colors).

## Nonactive Figures and Shared Colors

### Overview

Set `ShareColors` to on to conserve resources and to off to allow rapid colormap change.

### More Detail

Since nonactive figures are still visible, it is generally desirable for them to display correctly colored. However, if a number of figures with different colormaps exist simultaneously, or have large colormaps, the computer's color resources may not be able to display all figures correctly colored. When `ShareColors` is on, the figure does not redefine a color in the system color table if that color already exists.

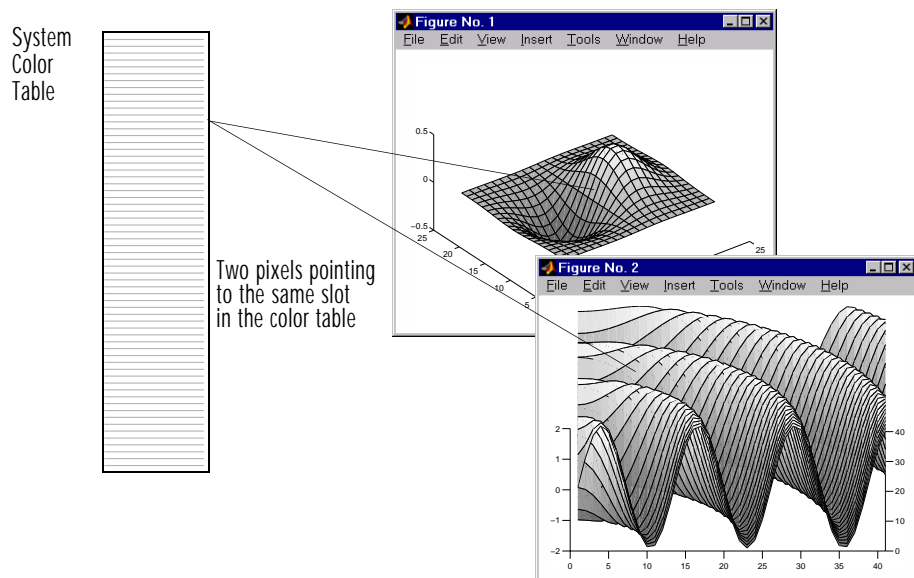

While sharing colors is a more efficient use of resources, it prevents MATLAB from rapidly changing the colormap (for example, as the `spinmap` function does). This is because MATLAB cannot change the value of a color slot in the system color table if other pixels also point to that slot for their color definition. It must find another slot for the new color. Changing color slot pixel assignments requires re-rendering (i.e., recomputing color values and

reassigning pixels to these colors) of the figure whose colormap you are altering.

If you want to change a figure's colormap rapidly, you should disable color sharing.

```
set(fig_handle, 'ShareColors', 'off')
```

Note that the new colormap must be the same size as the original one to avoid rerendering the figure. Look at the `spinmap` M-file for an example of this technique.

## Dithering Truecolor on Indexed Color Systems

### Overview

Set `DithermapMode` to `manual` to use the current `Dithermap` or `auto` to force MATLAB to create a new `Dithermap` based on the colors displayed in the figure.

### More Detail

MATLAB enables you to take advantage of truecolor systems (24-bit displays) by specifying `CData` as RGB triples, instead of values that index into the figure colormap. Index color systems interpret truecolor specifications by mapping each color to the closest color in the dithermap, which is assigned to the `Dithermap` property. MATLAB uses the Floyd-Steinberg algorithm to perform the mapping.

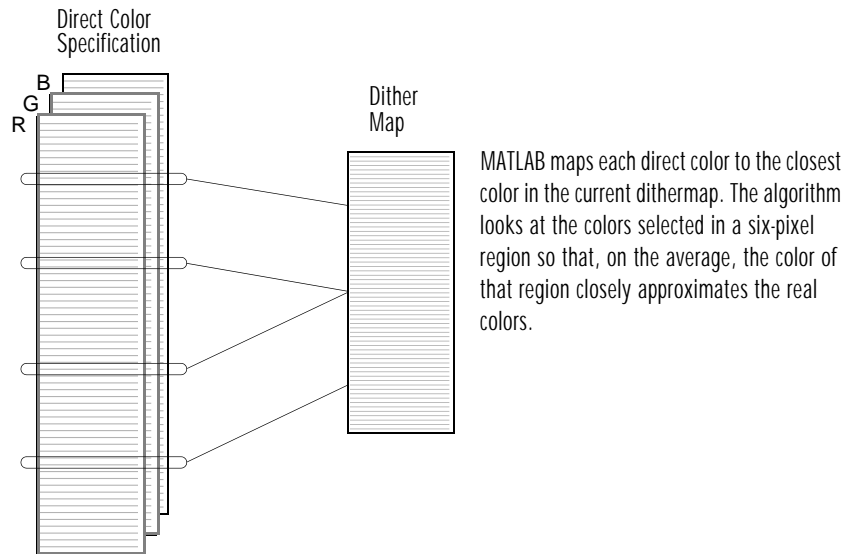

The dithermap is a colormap that replaces the figure colormap (which is not used in this case). The default dithermap contains a sampling of colors from the entire spectrum. This produces reasonably good quality with any object coloring. However, if the figure contains objects of primarily one color, a dithermap concentrated in the same color produces better color resolution.

### Auto Dither Mode

When you set `DithermapMode` to `auto`, MATLAB automatically creates a dithermap based on the colors in the figure. MATLAB produces an appropriate dithermap using the minimum variance quantization algorithm; however, the process is time consuming. Also, MATLAB regenerates the dithermap each time it re-renders the figure.

To avoid excessive rendering time, you should reset `DithermapMode` to `manual` after MATLAB generates the dithermap. MATLAB then uses this dithermap without regenerating it until you once again set `DithermapMode` to `auto`. You do not need to regenerate the dithermap unless you change the colors used in the figure.

You can save a dithermap by assigning the `Dithermap` property to a variable and saving it as a MAT-file.

```
set(gcf, 'DithermapMode', 'auto')
```

MATLAB creates a dithermap, which you can then save.

```
dmap = get(gcf, 'Dithermap');  
save DitherMaps dmap
```

### Dithermap Size

To obtain the highest color resolution, the default dithermap is as large as the system allows. This is usually less than 256 colors because a certain number of slots are reserved for system colors. Also, MATLAB fixed colors are not overwritten by the dithermap.

### Effects of Dithering

Dithering reduces the resolution of the displayed graphics because the colors are mapped in groups of six pixels. For example, suppose the color of one pixel is defined as orange, but the dithermap does not have this color. MATLAB selects combinations of colors from the dithermap that, taken together as a six-pixel group, approximate the color orange.

## Selecting Drawing Methods

MATLAB enables you to select different techniques for drawing graphics. The combination of settings you select depends on the type of graphics you are producing.

There are four figure properties that affect how MATLAB draws graphics:

- `BackingStore` – allows faster redrawing when obscured figure windows are exposed.
- `DoubleBuffer` – produces flash-free rendering for simple animations.
- `Renderer` and `RendererMode` – specifies different rendering methods or allows MATLAB to make the selection.

### Backing Store

#### Overview

Set `BackingStore` to `on` to produce fast redraws of previously obscured windows. Disable `BackingStore` to use less system memory.

#### More Details

The term “backing store” refers to an off-screen pixel buffer used to store a copy of the figure window’s contents. When you move or delete windows on your display, previously obscured windows can become exposed (even partially), requiring the computer system to redraw these windows. With backing store enabled, MATLAB simply copies an exposed figure window’s contents from the buffer to the screen.

The `BackingStore` property is `on` by default as this provides the most desirable behavior. However, the off-screen pixel buffers required for each figure window do consume system memory. If memory is limited on your system, set `BackingStore` to `off` to release the memory used by these buffers.

### Double Buffering

#### Overview

Set `DoubleBuffer` to `on` when animating lines rendered in painters with `EraseMode` set to `normal`.

### More Details

Double buffering is the process of drawing into an off-screen pixel buffer and then blitting the buffer contents to the screen once the drawing is complete (instead of drawing directly to the screen where the process of drawing is visible as it progresses). Double buffering generally produces flash-free rendering for simple animations (such as those involving lines, as opposed to objects containing large numbers of polygons).

The figure `DoubleBuffer` property accepts the values `on` and `off`, with `off` being the default. Double buffering works only when the figure `Renderer` property is set to `painters`.

Use double buffering with the animated object's `EraseMode` property set to `normal`.

## Selecting a Renderer

### Overview

MATLAB automatically selects the best renderer based on the complexity of the graphics objects and the options available on your system.

### More Details

A renderer is the software that processes graphics data (such as vertex coordinates) into a form that MATLAB can use to draw into the figure. MATLAB supports three renderers:

- Painters
- Zbuffer
- OpenGL

### Painters

Painters method is faster when the figure contains only simple or small graphics. It cannot be used with lighting.

### Z-Buffer

Z-buffering is the process of determining how to render each pixel by drawing only the front-most object, as opposed to drawing all objects back to front,



redrawing objects that obscure those behind. The pixel data is buffered and then blitted to the screen all at once.

Z-buffering is generally faster for more complex graphics, but may be slower for very simple graphics. You can set the `Renderer` property to whatever produces the fastest drawing (either `zbuffer` or `painters`), or let MATLAB decide which method to use by setting the `RenderMode` property to `auto` (the default).

**Printing from Z-Buffer.** You can select the resolution of the PostScript file produced by the `print` command using the `-r` option. By default, MATLAB prints Z-buffered figures at a medium resolution of 150 dpi (the default with `Renderer` set to `painters` is 864 dpi).

The size of the file generated from a Z-buffer figure does not depend on its contents, just the size of the figure. To decrease the file size, make the `PaperPosition` property smaller before printing (or set `PaperPositionMode` to `auto` and resize the figure window).

## OpenGL

OpenGL is available on many computer systems. It is generally faster than either `painters` or `zbuffer` and in some cases enables MATLAB to use the system's graphics hardware (which results in significant speed increase). See the figure `Renderer` property for more information.

**Limitations of OpenGL.** OpenGL has two limitations when compared to `painters` and `zbuffer`:

- OpenGL does not interpolate colors within the figure colormap; all color interpolation is performed through the RGB color cube, which may produce unexpected results.
- OpenGL does not support Phong lighting.









## Specifying the Figure Pointer





MATLAB indicates the position of the pointer (cursor) within the figure window using a graphical symbol. You can select a pointer from 15 predefined symbols (see table below) or you can define your own symbol. By convention, each of the predefined symbols has a purpose associated with it (although MATLAB enforces no rules for the use of any symbols).

You specify the pointer symbol by setting the value of the figure `Pointer` property. For example,

```
set(gcf, 'Pointer', 'arrow')
```

The following table shows the predefined symbols, the associated specifier, and describes typical use.

Purpose	Specifier	Typical Symbol
Locate a point on a graphics object	crosshair	+
Select a point anywhere in the figure	arrow	
Indicate the system is busy	watch	
Resize an object from the top-left corner	topl	
Resize an object from the top-right corner	topr	
Resize an object from the bottom-left corner	botl	
Resize an object from the bottom-right corner	botr	
View the actual hot spot	circle	
Locate a point	cross	
Use as popular symbol	fleur	

Purpose	Specifier	Typical Symbol
Resize an object from the left side	left	
Resize an object from the right side	right	
Resize an object from the top	top	
Resize an object from the bottom	bottom	
Align a point with other objects on the display	fullcross	
See the next section for information on defining your own pointer shape	custom	

## Defining Custom Pointers

When you set the `Pointer` property to `custom`, MATLAB displays the pointer you define using the `PointerShapeCData` and the `PointerShapeHotSpot` properties. Custom pointers are 16-by-16 pixels, where each pixel can be either black, white, or transparent.

Specify the pointer by creating a 16-by-16 matrix containing elements that are:

- 1s where you want the pixel black
- 2s where you want the pixel white
- NaNs where you want the pixel transparent

Assign the matrix to the figure `PointerShapeCData` property. MATLAB displays the defined pointer whenever the pointer is in the figure window.

The `PointerShapeHotSpot` property specifies the pixel that indicates the pointer location. MATLAB then stores this location in the root `PointerLocation` property. Set the `PointerShapeHotSpot` property to a two-element vector specifying the row and column indices in the `PointerShapeCData` matrix that corresponds to the pixel specifying the location. The default value for this property is `[1 1]`, which corresponds to the upper-left corner of the pointer.

### Example – Two Custom Pointers

One way to create a custom pointer is to assign values to a 16-by-16 matrix by hand, as illustrated in the following example.

First, initialize the matrix, setting all values to 2. Create a black border 1 pixel wide. Add alignment marks.

```
P = ones(16)+1;
P(1,:) = 1; P(16,:) = 1;
P(:,1) = 1; P(:,16) = 1;
P(1:4,8:9) = 1; P(13:16,8:9) = 1;
P(8:9,1:4) = 1; P(8:9,13:16) = 1;
P(5:12,5:12) = NaN; % Create a transparent region in the center
set(gcf,'Pointer','custom','PointerShapeCData',P,...
    'PointerShapeHotSpot',[9 9])
```

The last statement sets the `Pointer` property to custom, assigns the matrix to the `PointerShapeCData` property, and selects the “hot spot” as element (9,9).

MATLAB now uses the custom pointer within the figure window.

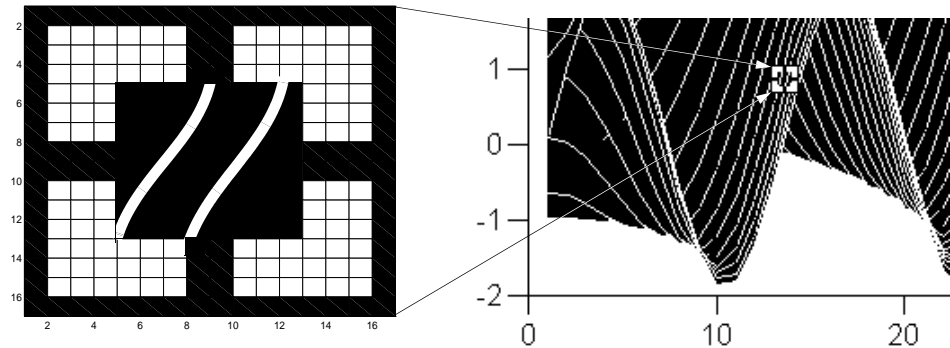

**Creating Pointers from Functions.** You can use a mathematical function to define the `PointerShapeCData` matrix. For example, evaluating the function,  $2(\sin(\sqrt{x^2 + y^2}))$

```
g = 0:.2:20;
[X,Y] = meshgrid(g);
```

```
Z = 2*sin(sqrt(X.^2 + Y.^2));
mesh(Z);
```

produces an interesting surface.

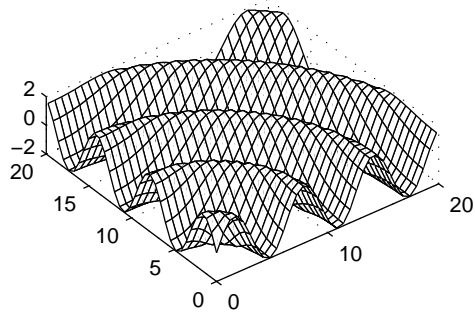

Use the values of Z to create a pointer sampling fewer points so that Z is a 16-by-16 matrix.

```
g = linspace(0,20,16);
[X,Y] = meshgrid(g);
Z = 2*sin(sqrt(X.^2 + Y.^2));
set(gcf, 'Pointer', 'custom', ...
        'PointerShapeCData', flipud((Z>0) + 1))
```

The statement, `flipud((Z>0) + 1)` sets all values in Z that are greater than zero to two (in MATLAB, `true + 1 = 2`), less than zero to one (`false + 1 = 1`) and then flips the data around so that element (1,1) is the upper-left corner.

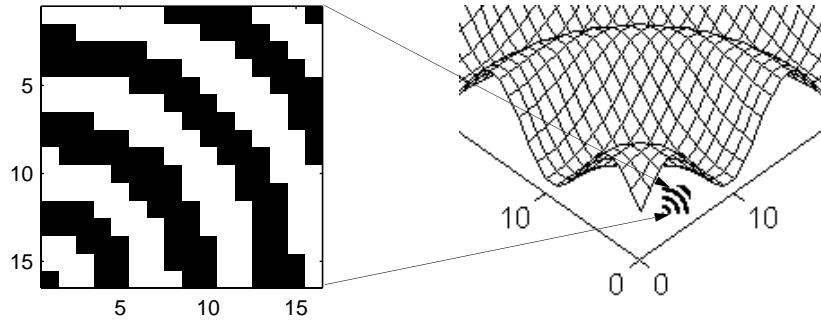

## Interactive Graphics

Figure objects contain a number of properties designed to facilitate user interaction with the figure. These properties fall into two categories.

Properties related to callback routine execution:

- `BusyAction`
- `ButtonDownFcn`
- `CreateFcn`
- `DeleteFcn`
- `KeyPressFcn`
- `Interruptible`
- `ResizeFcn`
- `WindowButtonDownFcn`, `WindowButtonMotionFcn`, and `WindowButtonUpFcn`

Properties that contain information about MATLAB's state:

- `CurrentAxes`
- `CurrentCharacter`
- `CurrentMenu`
- `CurrentObject`
- `CurrentPoint`
- `SelectionType`

The online manual, [Creating Graphical User Interfaces](#), provides information on creating programs that incorporate interactive graphics.





---

# 3-D Visualization

---

Visualization is the use of graphical representations of information to make certain characteristics or values more apparent. Visualization conveys information by employing geometric forms (e.g., surfaces, solids) and colors that are mapped to data values in particular ways. The geometric forms may represent real-life objects, such as an airplane or wave guide, or may be graphical elements that indicate data values, such as streamlines or slice planes.

This collection of topics introduces visualization techniques and illustrates the application of these techniques to specific types of data. The following list summarizes the contents of this collection:

- **Creating 3-D Graphs** – includes information about 3-D line and surface graphs.
- **Defining the View** – discusses how to set the view point and control the aspect ratio and projection type. This section describes how to compose the scene you want to display.
- **Lighting as a Visualization Tool** – illustrates the various lighting effects you can employ to add realism and improve shape definition in 3-D views.
- **Transparency** – describes how to make objects translucent.
- **Creating 3-D Models with Patches** – shows how to use MATLAB patch objects to define 3-D shell representations of physical shapes. Patches support x-, y-, and z-coordinates as well as face and vertex data specification.
- **Volume Visualization Techniques** – employs a variety of MATLAB's visualization techniques to display both scalar and vector volume data.

## Related Information

The following sections provide information that is useful in understanding the techniques described in this section:

- **Graphics** – covers the fundamentals of plotting in MATLAB. It discusses MATLAB's standard plotting routines (line plots, pie charts, histograms,

---

etc.) as well as graph formatting and annotation. In addition, this section describes the graphics object hierarchy, manipulating object properties, and the use of important figure and axes properties.

# Creating 3-D Graphs

---

<b>Building a 3-D Graph</b> . . . . .	10-2
<b>Line Plots of 3-D Data</b> . . . . .	10-3
<b>Representing a Matrix As a Surface</b> . . . . .	10-5
Mesh and Surface Plots . . . . .	10-5
Visualizing Functions of Two Variables . . . . .	10-6
Surface Plots of Nonuniformly Sampled Data . . . . .	10-8
Parametric Surfaces . . . . .	10-10
Hidden Line Removal . . . . .	10-12
<b>Coloring Mesh and Surface Plots</b> . . . . .	10-13
Colormaps . . . . .	10-13
Indexed Colors – Direct and Scaled Colormapping . . . . .	10-16
Example – Mapping Surface Curvature to Color . . . . .	10-17
Altering Colormaps . . . . .	10-19
<b>Truecolor</b> . . . . .	10-21
<b>Texture Mapping</b> . . . . .	10-24

### Topics in 3-D Graphing

This section discusses how to plot 3-D vector and 2-D matrix (gridded) data.

- A Typical 3-D Graph – steps followed in creating a typical 3-D graph.
- Line Plots of 3-D Data – lines plots of data having x-, y-, and z-coordinates.
- Representing a Matrix as a Surface – graphs of matrix (2-D gridded) data.
- Coloring Mesh and Surface Plots – describes how MATLAB colors surface and mesh plots, including colormaps, truecolor, and texture mapping.

## A Typical 3-D Graph

This table illustrates typical steps involved in producing 3-D scenes containing either data graphs or models of 3-D objects. Example applications include pseudocolor surfaces illustrating the values of functions over specific regions and objects drawn with polygons and colored with light sources to produce realism. Usually, you follow either step 4a or step 4b.

Step	Typical Code
1 Prepare your data	<code>Z = peaks(20);</code>
2 Select window and position plot region within window	<code>figure(1) subplot(2,1,2)</code>
3 Call 3-D graphing function	<code>h = surf(Z);</code>
4 Set colormap and shading algorithm	<code>colormap hot shading interp set(h,'EdgeColor','k')</code>
5 Add lighting	<code>light('Position',[-2,2,20]) lighting phong material([0.4,0.6,0.5,30]) set(h,'FaceColor',[0.7 0.7 0],...       'BackFaceLighting','lit')</code>
6 Set viewpoint	<code>view([30,25]) set(gca,'CameraViewAngleMode','Manual')</code>
7 Set axis limits and tick marks	<code>axis([5 15 5 15 -8 8]) set(gca,'ZTickLabel','Negative  Positive')</code>
8 Set aspect ratio	<code>set(gca,'PlotBoxAspectRatio',[2.5 2.5 1])</code>
9 Annotate the graph with axis labels, legend, and text	<code>xlabel('X Axis') ylabel('Y Axis') zlabel('Function Value') title('Peaks')</code>
10 Print graph	<code>set(gcf,'PaperPositionMode','auto') print -dps2</code>

## Line Plots of 3-D Data

The 3-D analog of the `plot` function is `plot3`. If  $x$ ,  $y$ , and  $z$  are three vectors of the same length,

```
plot3(x,y,z)
```

generates a line in 3-D through the points whose coordinates are the elements of  $x$ ,  $y$ , and  $z$  and then produces a 2-D projection of that line on the screen. For example, these statements produce a helix.

```
t = 0:pi/50:10*pi;  
plot3(sin(t),cos(t),t)  
axis square; grid on
```

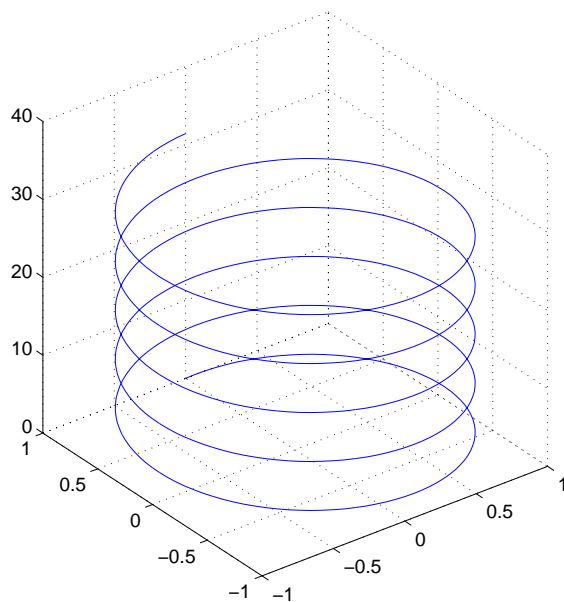

### Plotting Matrix Data

If the arguments to `plot3` are matrices of the same size, MATLAB plots lines obtained from the columns of  $X$ ,  $Y$ , and  $Z$ . For example,

```
[X,Y] = meshgrid([-2:0.1:2]);
```

```
Z = X.*exp(-X.^2-Y.^2);  
plot3(X,Y,Z)  
grid on
```

Notice how MATLAB cycles through line colors.

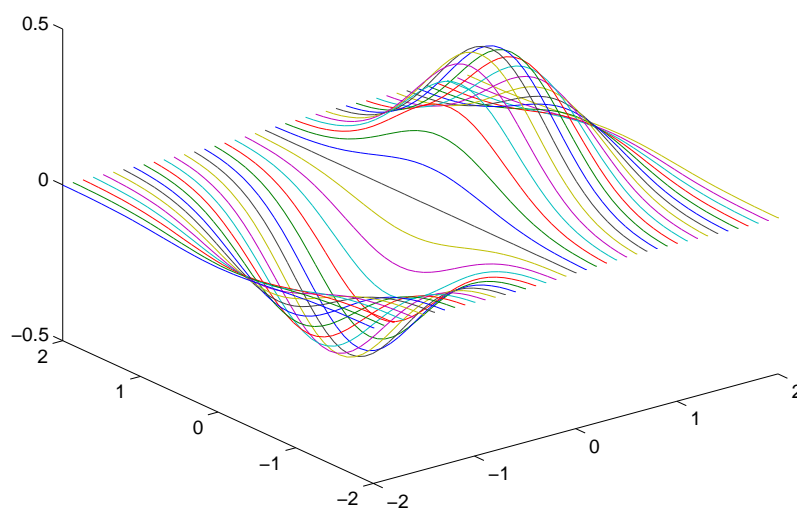

## Representing a Matrix As a Surface

MATLAB defines a surface by the  $z$ -coordinates of points above a rectangular grid in the  $x$ - $y$  plane. The plot is formed by joining adjacent points with straight lines. Surface plots are useful for visualizing matrices that are too large to display in numerical form and for graphing functions of two variables.

MATLAB can create different forms of surface plots. Mesh plots are wire-frame surfaces that color only the lines connecting the defining points. Surface plots display both the connecting lines and the faces of the surface in color. This table lists the various forms.

### Surface Plotting Functions

Function	Used to Create
<code>mesh</code> , <code>surf</code>	Surface plot
<code>meshc</code> , <code>surfc</code>	Surface plot with contour plot beneath it
<code>meshz</code>	Surface plot with curtain plot (reference plane)
<code>pcolor</code>	Flat surface plot (value is proportional only to color)
<code>surf1</code>	Surface plot illuminated from specified direction
<code>surface</code>	Low-level function (on which high-level functions are based) for creating surface graphics objects

### Mesh and Surface Plots

The `mesh` and `surf` commands create 3-D surface plots of matrix data. If  $Z$  is a matrix for which the elements  $Z(i, j)$  define the height of a surface over an underlying  $(i, j)$  grid, then

```
mesh(Z)
```

generates a colored, wire-frame view of the surface and displays it in a 3-D view. Similarly,

```
surf(Z)
```



generates a colored, faceted view of the surface and displays it in a 3-D view. Ordinarily, the facets are quadrilaterals, each of which is a constant color, outlined with black mesh lines, but the shading command allows you to eliminate the mesh lines (`shading flat`) or to select interpolated shading across the facet (`shading interp`).

Surface object properties provide additional control over the visual appearance of the surface. You can specify edge line styles, vertex markers, face coloring, lighting characteristics, and so on.

## Visualizing Functions of Two Variables

The first step in displaying a function of two variables,  $z = f(x,y)$ , is to generate  $X$  and  $Y$  matrices consisting of repeated rows and columns, respectively, over the domain of the function. Then use these matrices to evaluate and graph the function.

The `meshgrid` function transforms the domain specified by two vectors,  $x$  and  $y$ , into matrices,  $X$  and  $Y$ . You then use these matrices to evaluate functions of two variables. The rows of  $X$  are copies of the vector  $x$  and the columns of  $Y$  are copies of the vector  $y$ .

To illustrate the use of `meshgrid`, consider the  $\sin(r)/r$  or sinc function. To evaluate this function between  $-8$  and  $8$  in both  $x$  and  $y$ , you need pass only one vector argument to `meshgrid`, which is then used in both directions.

```
[X,Y] = meshgrid(-8:.5:8);
R = sqrt(X.^2 + Y.^2) + eps;
```

The matrix  $R$  contains the distance from the center of the matrix, which is the origin. Adding `eps` prevents the divide by zero (in the next step) that produces `Inf` values in the data.

Forming the sinc function and plotting  $Z$  with `mesh` results in the 3-D surface.

```
Z = sin(R)./R;
mesh(Z)
```

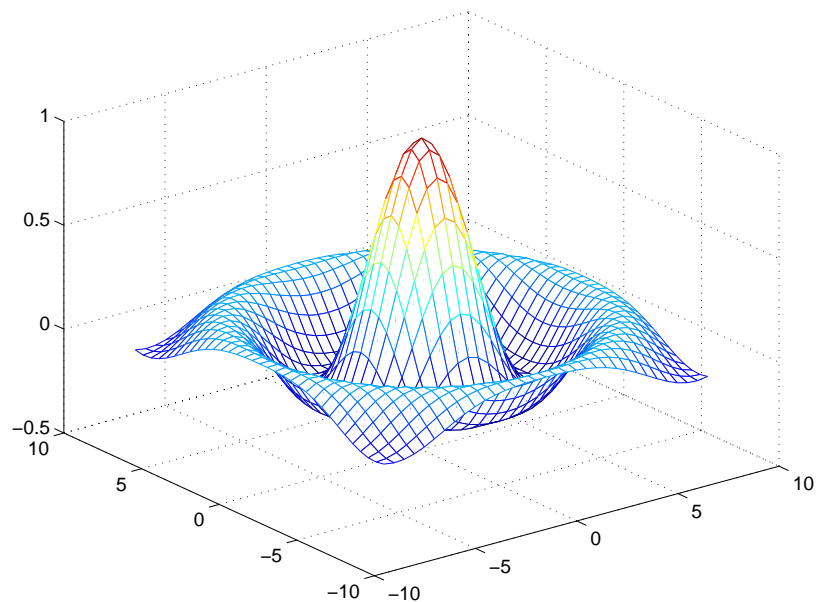

### Emphasizing Surface Shape

MATLAB provides a number of techniques that can enhance the information content of your graphs. For example, this graph of the sinc function uses the same data as the previous graph, but employs lighting and view adjustment to emphasize the shape of the graphed function (`daspect`, `axis`, `camlight`, `view`).

```
surf(X,Y,Z,'FaceColor','interp',...  
      'EdgeColor','none',...  
      'FaceLighting','phong')  
daspect([5 5 1])  
axis tight  
view(-50,30)  
camlight left
```

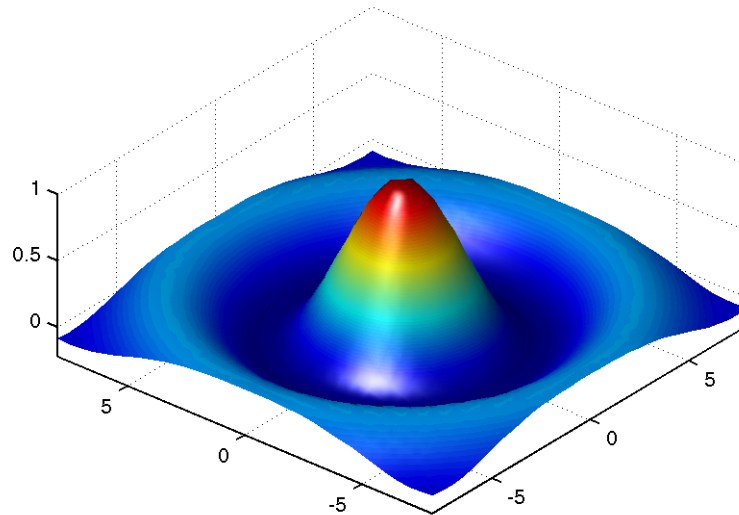

See the `surf` function for more information on surface plots.

## Surface Plots of Nonuniformly Sampled Data

You can use `meshgrid` to create a grid of uniformly sampled data points at which to evaluate and graph the `sinc` function. MATLAB then constructs the surface plot by connecting neighboring matrix elements to form a mesh of quadrilaterals.

To produce a surface plot from nonuniformly sampled data, first use `griddata` to interpolate the values at uniformly spaced points, and then use `mesh` and `surf` in the usual way.

### Example– Displaying Nonuniform Data on a Surface

This example evaluates the `sinc` function at random points within a specific range and then generates uniformly sampled data for display as a surface plot. The process involves these steps:

- Use `linspace` to generate evenly spaced values over the range of your unevenly sampled data.

- Use `meshgrid` to generate the plotting grid with the output of `linspace`.
- Use `griddata` to interpolate the irregularly sampled data to the regularly spaced grid returned by `meshgrid`.
- Use a plotting function to display the data.

- 1 First, generate unevenly sampled data within the range  $[-8, 8]$  and use it to evaluate the function.

```
x = rand(100,1)*16-8;  
y = rand(100,1)*16-8;  
r = sqrt(x.^2 + y.^2) + eps;  
z = sin(r)./r;
```

- 2 The `linspace` function provides a convenient way to create uniformly spaced data with the desired number of elements. The following statements produce vectors over the range of the random data with the same resolution as that generated by the `-8:.5:8` statement in the previous `sinc` example.

```
xlin = linspace(min(x),max(x),33);  
ylin = linspace(min(y),max(y),33);
```

- 3 Now use these points to generate a uniformly spaced grid.

```
[X,Y] = meshgrid(xlin,ylin);
```

- 4 The key to this process is to use `griddata` to interpolate the values of the function at the uniformly spaced points, based on the values of the function at the original data points (which are random in this example). This statement uses a triangle-based cubic interpolation to generate the new data.

```
Z = griddata(x,y,z,X,Y, 'cubic');
```

- 5 Plotting the interpolated and the nonuniform data produces

```
mesh(X,Y,Z) %interpolated  
axis tight; hold on  
plot3(x,y,z, '.', 'MarkerSize',15) %nonuniform
```

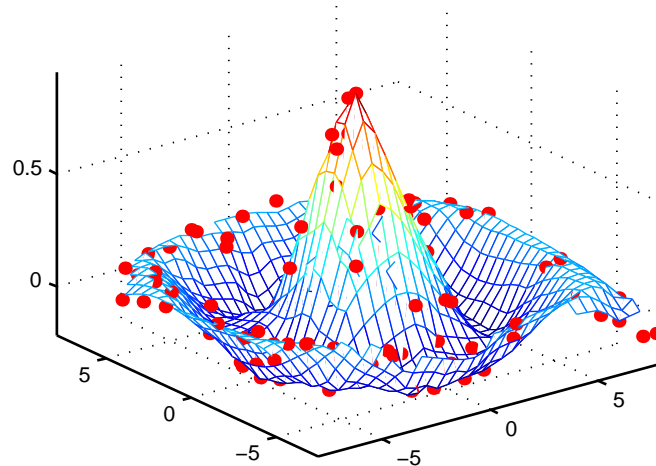

## Parametric Surfaces

The functions that draw surfaces can take two additional vector or matrix arguments to describe surfaces with specific  $x$  and  $y$  data. If  $Z$  is an  $m$ -by- $n$  matrix,  $x$  is an  $n$ -vector, and  $y$  is an  $m$ -vector, then

$$\text{mesh}(x, y, Z, C)$$

describes a mesh surface with vertices having color  $C(i, j)$  and located at the points

$$(x(j), y(i), Z(i, j))$$

where  $x$  corresponds to the columns of  $Z$  and  $y$  to its rows.

More generally, if  $X$ ,  $Y$ ,  $Z$ , and  $C$  are matrices of the same dimensions, then

$$\text{mesh}(X, Y, Z, C)$$

describes a mesh surface with vertices having color  $C(i, j)$  and located at the points

$$(X(i, j), Y(i, j), Z(i, j))$$

This example uses spherical coordinates to draw a sphere and color it with the pattern of pluses and minuses in a Hadamard matrix, an orthogonal matrix used in signal processing coding theory. The vectors  $\theta$  and  $\phi$  are in the range  $-\pi \leq \theta \leq \pi$  and  $-\pi/2 \leq \phi \leq \pi/2$ . Because  $\theta$  is a row vector and  $\phi$  is a column vector, the multiplications that produce the matrices  $X$ ,  $Y$ , and  $Z$  are vector outer products.

```
k = 5;  
n = 2^k-1;  
theta = pi*(-n:2:n)/n;  
phi = (pi/2)*(-n:2:n)'/n;  
X = cos(phi)*cos(theta);  
Y = cos(phi)*sin(theta);  
Z = sin(phi)*ones(size(theta));  
colormap([0 0 0;1 1 1])  
C = hadamard(2^k);  
surf(X,Y,Z,C)  
axis square
```

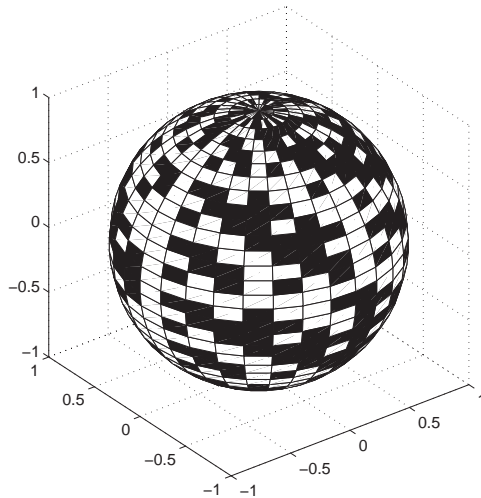

## Hidden Line Removal

By default, MATLAB removes lines that are hidden from view in mesh plots, even though the faces of the plot are not colored. You can disable hidden line removal and allow the faces of a mesh plot to be transparent with the command

```
hidden off
```

This is the surface plot with hidden set to off.

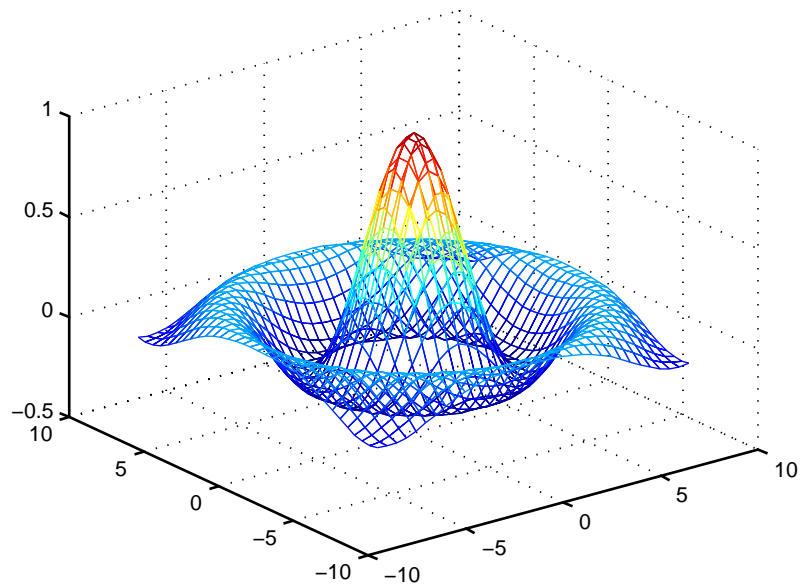

## Coloring Mesh and Surface Plots

You can enhance the information content of surface plots by controlling the way MATLAB applies color to these plots. MATLAB can map particular data values to colors specified explicitly or can map the entire range of data to a predefined range of colors called a *colormap*.

There are two coloring techniques:

- Indexed Color – MATLAB colors the surface plot by assigning each data point an index into the figure's colormap. The way MATLAB applies these colors depends on the type of shading used (faceted, flat, or interpolated).
- Truecolor – MATLAB colors the surface plot using the explicitly specified colors (i.e., the RGB triplets). The way MATLAB applies these colors depends on the type of shading used (faceted, flat, or interpolated). To be rendered accurately, truecolor requires computers with 24-bit displays; however, MATLAB simulates truecolor on indexed systems. See the `shading` command for information on the types of shading.

The type of color data you specify (i.e., single values or RGB triplets) determines how MATLAB interprets it. When you create a surface plot, you can:

- Provide no explicit color data, in which case MATLAB generates colormap indices from the  $z$ -data.
- Specify an array of color data that is equal in size to the  $z$ -data and is used for indexed colors.
- Specify an  $m$ -by- $n$ -by-3 array of color data that defines an RGB triplet for each element in the  $m$ -by- $n$   $z$ -data array and is used for truecolor.

### Colormaps

Each MATLAB figure window has a colormap associated with it. A colormap is simply a three-column matrix whose length is equal to the number of colors it defines. Each row of the matrix defines a particular color by specifying three values in the range 0 to 1. These values define the RGB components (i.e., the intensities of the red, green, and blue video components).

The `colormap` function, with no arguments, returns the current figure's colormap.



For example, MATLAB's default colormap contains 64 colors and the 57th color is red.

```
cm = colormap;
cm(57,:)
ans =
    1    0    0
```

This table lists some representative RGB color definitions.

Red	Green	Blue	Color
0	0	0	black
1	1	1	white
1	0	0	red
0	1	0	green
0	0	1	blue
1	1	0	yellow
1	0	1	magenta
0	1	1	cyan
0.5	0.5	0.5	gray
0.5	0	0	dark red
1	0.62	0.40	copper
0.49	1	0.83	aquamarine

You can create colormaps with MATLAB's array operations or you can use any of several functions that generate useful maps, including `hsv`, `hot`, `cool`, `summer`, and `gray`. Each function has an optional parameter that specifies the number of rows in the resulting map.

For example,

```
hot(m)
```

creates an  $m$ -by-3 matrix whose rows specify the RGB intensities of a map that varies from black, through shades of red, orange, and yellow, to white.

If you do not specify the colormap length, MATLAB creates a colormap the same length as the current colormap. The default colormap is `jet(64)`.

If you use long colormaps (> 64 colors) in each of several figures windows, it may become necessary for the operating system to swap in different color lookup tables as the active focus is moved among the windows. See “Controlling How MATLAB Uses Color” in the “Figure Properties” chapter for more information on how MATLAB manages color.

### Displaying Colormaps

The `colorbar` function displays the current colormap, either vertically or horizontally, in the figure window along with your graph. For example, the statements

```
[x,y] = meshgrid([-2:.2:2]);  
Z = x.*exp(-x.^2-y.^2);  
surf(x,y,Z,gradient(Z))  
colorbar
```

produce a surface plot and a vertical strip of color corresponding to the colormap.

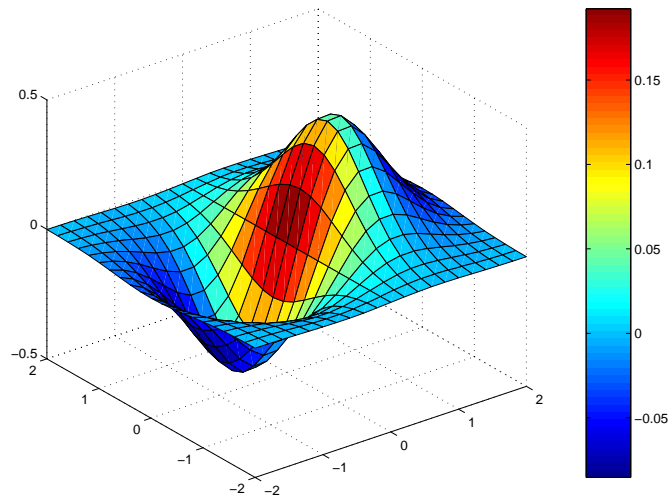

Note how the colorbar indicates the mapping of data value to color with the axis labels.

## Indexed Colors – Direct and Scaled Colormapping

MATLAB can use two different methods to map indexed color data to the colormap – direct and scaled.

### Direct Mapping

Direct mapping uses the color data directly as indices into the colormap. For example, a value of 1 points to the first color in the colormap, a value of 2 points to the second color, and so on. If the color data is noninteger, MATLAB rounds it towards zero. Values greater than the number of colors in the colormap are set equal to the last color in the colormap (i.e., the number `length(colormap)`). Values less than 1 are set to 1.

### Scaled Mapping

Scaled mapping uses a two-element vector `[cmin cmax]` (specified with the `caxis` command) to control the mapping of color data to the figure colormap. `cmin` specifies the data value to map to the first color in the colormap and `cmax`

specifies the data value to map to the last color in the colormap. Data values in between are linearly transformed from the second to the next-to-last color, using the expression.

```
colormap_index = fix((color_data-cmin)/(cmax-cmin)*cm_length)+1
```

`cm_length` is the length of the colormap.

By default, MATLAB sets `cmin` and `cmax` to span the range of the color data of all graphics objects within the axes. However, you can set these limits to any range of values. This enables you to display multiple axes within a single figure window and use different portions of the figure's colormap for each one. See the "Calculating Color Limits" section in the "Axes Properties" chapter for an example that uses color limits.

By default, MATLAB uses scaled mapping. To use direct mapping, you must turn off scaling when you create the plot. For example,

```
surf(Z,C,'CDataMapping','direct')
```

See `surface` for more information on specifying color data.

### Specifying Indexed Colors

When creating a surface plot with a single matrix argument, `surf(Z)` for example, the argument `Z` specifies both the height and the color of the surface. MATLAB transforms `Z` to obtain indices into the current colormap.

With two matrix arguments, the statement

```
surf(Z,C)
```

independently specifies the color using the second argument.

### Example – Mapping Surface Curvature to Color

The Laplacian of a surface plot is related to its curvature; it is positive for functions shaped like  $i^2 + j^2$  and negative for functions shaped like  $-(i^2 + j^2)$ . The function `del2` computes the discrete Laplacian of any matrix. For example, use `del2` to determine the color for the data returned by `peaks`.

```
P = peaks(40);  
C = del2(P);  
surf(P,C)  
colormap hot
```

Creating a color array by applying the Laplacian to the data is useful because it causes regions with similar curvature to be drawn in the same color.

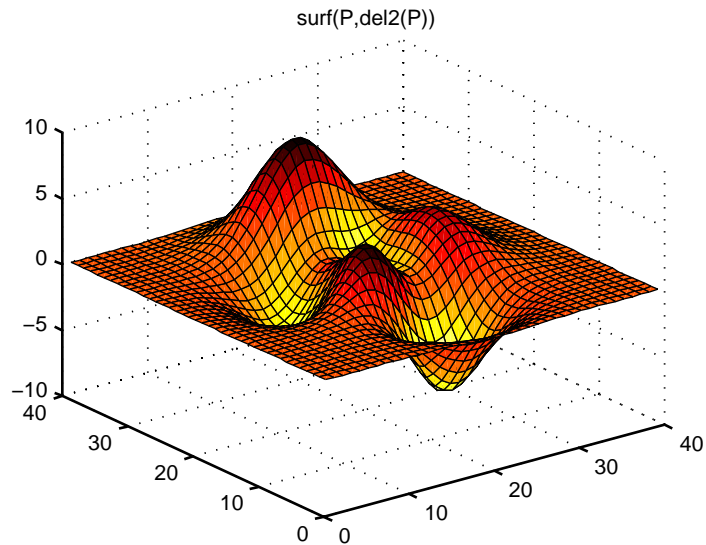

Compare this surface coloring with that produced by the statements

```
surf(P)  
colormap hot
```

which use the same colormap, but maps regions with similar z value (height above the x-y plane) to the same color.

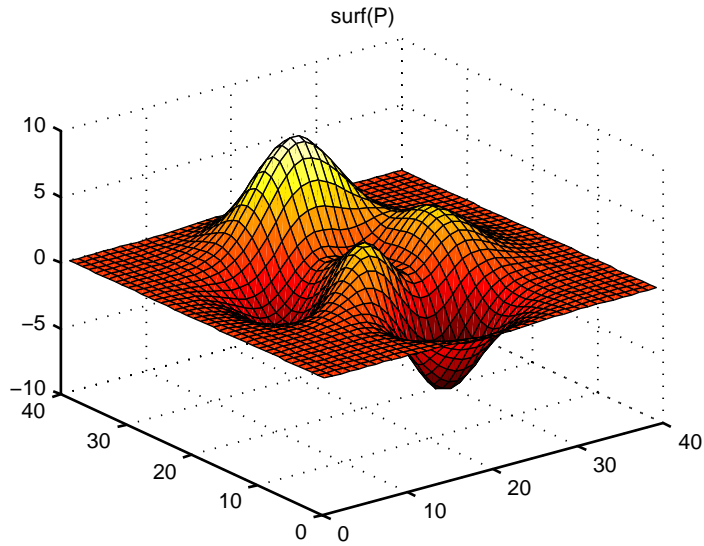

## Altering Colormaps

Because colormaps are matrices, you can manipulate them like other arrays. The `brighten` function takes advantage of this fact to increase or decrease the intensity of the colors. Plotting the values of the R, G, and B components of a colormap using `rgbplot` illustrates the effects of `brighten`.

`brighten(copper,-0.5)`

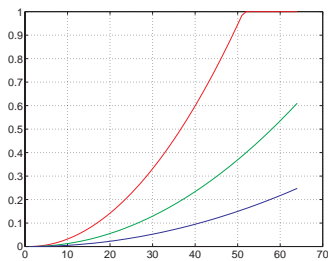

`copper`

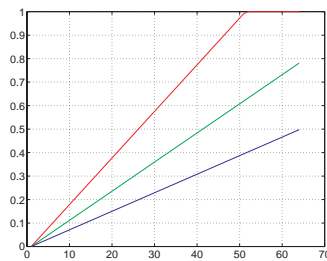

`brighten(copper,0.5)`

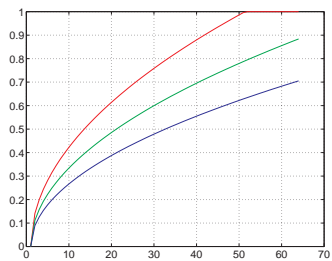

### NTSC Color Encoding

The brightness component of television signals uses the NTSC color encoding scheme.

```
b = .30*red + .59*green + .11*blue  
  = sum(diag([.30 .59 .11])*map')';
```

Using the nonlinear grayscale map,

```
colormap([b b b])
```

effectively converts a color image to its NTSC black-and-white equivalent.

## Truecolor

Computer systems with 24-bit displays are capable of displaying over 16 million ( $2^{24}$ ) colors, as opposed to the 256 colors available on 8-bit displays. You can take advantage of this capability by defining color data directly as RGB values and eliminating the step of mapping numerical values to locations in a colormap.

Specify truecolor using an  $m$ -by- $n$ -by-3 array, where the size of  $Z$  is  $m$ -by- $n$ .

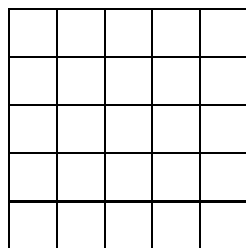

$m$ -by- $n$  matrix defining surface plot

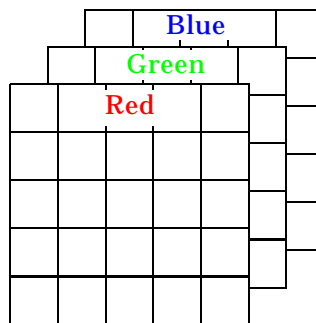

Corresponding  $m$ -by- $n$ -by-3 matrix specifying truecolor for the surface plot

For example, the statements

```
Z = peaks(25);
C(:, :, 1) = rand(25);
C(:, :, 2) = rand(25);
C(:, :, 3) = rand(25);
surf(Z, C)
```

create a plot of the peaks matrix with random coloring.



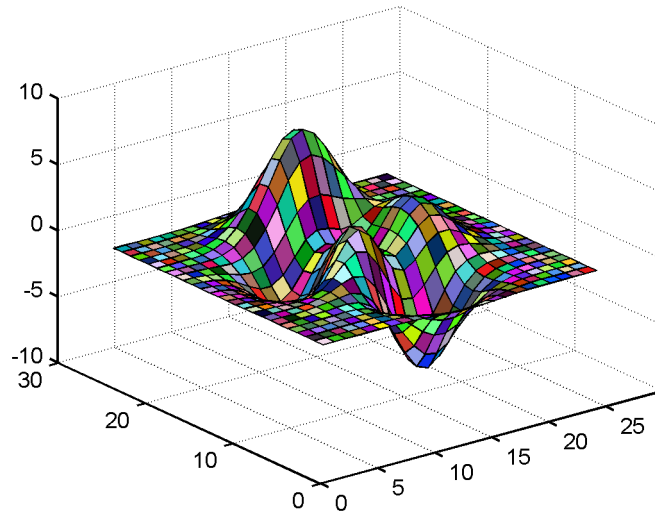

You can set surface properties as with indexed color.

```
surf(Z,C,'FaceColor','interp','FaceLighting','phong')  
camlight right
```

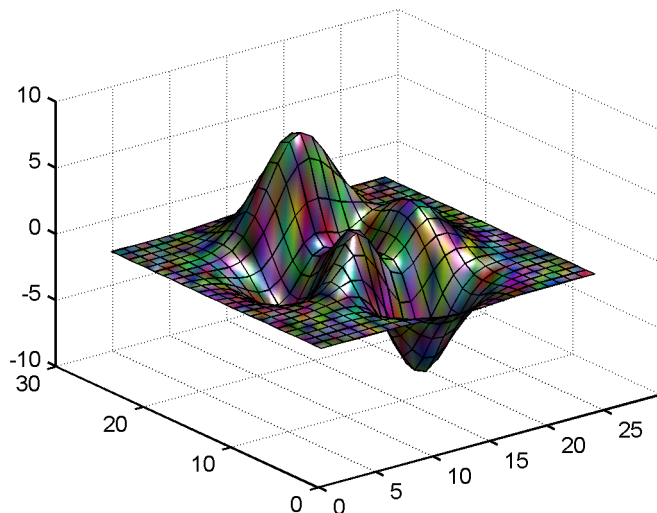

### Rendering Method for Truecolor

MATLAB always uses either OpenGL or the zbuffer render method when displaying truecolor. If the figure `RendererMode` property is set to `auto`, MATLAB automatically switches the value of the `Renderer` property to `zbuffer` whenever you specify truecolor data.

If you explicitly set `Renderer` to `painters` (this sets `RendererMode` to `manual`) and attempt to define an `image`, `patch`, or `surface` object using truecolor, MATLAB returns a warning and does not render the object.

See the `image`, `patch`, and `surface` functions for information on defining truecolor for these objects.

### Simulating Truecolor – Dithering

You can use truecolor on computers that do not have 24-bit displays. In this case, MATLAB uses a special colormap designed to produce results that are as close as possible, given the limited number of colors available. See “Dithering Truecolor on Indexed Color Systems” in the “Figure Properties” chapter for more information on the use of a dithermap.

## Texture Mapping

Texture mapping is a technique for mapping a 2-D image onto a 3-D surface by transforming color data so that it conforms to the surface plot. It allows you to apply a “texture,” such as bumps or wood grain, to a surface without performing the geometric modeling necessary to create a surface with these features. The color data can also be any image, such as a scanned photograph.

Texture mapping allows the dimensions of the color data array to be different from the data defining the surface plot. You can apply an image of arbitrary size to any surface. MATLAB interpolates texture color data so that it is mapped to the entire surface.

### Example – Texture Mapping a Surface

This example creates a spherical surface using the sphere function and texture maps it with an image of the earth taken from space. Because the earth image is a view of earth from one side, this example maps the image to only one side of the sphere, padding the image data with 1s. In this case, the image data is a 257-by-250 matrix so it is padded equally on each side with two 257-by-125 matrices of 1s by concatenating the three matrices together.

To use texture mapping, set the FaceColor to texturemap and assign the image to the surface's CData.

```
load earth % Load image data, X, and colormap, map
sphere; h = findobj('Type','surface');
hemisphere = [ones(257,125),...
              X,...
              ones(257,125)];
set(h,'CData',flipud(hemisphere),'FaceColor','texturemap')
colormap(map)
axis equal
view([90 0])
set(gca,'CameraViewAngleMode','manual')
view([65 30])
```

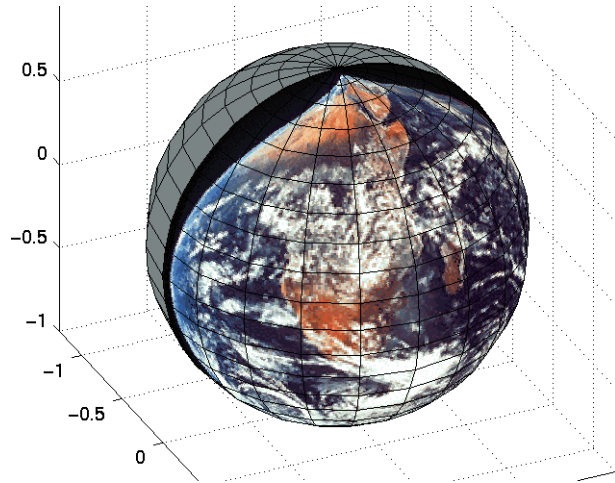
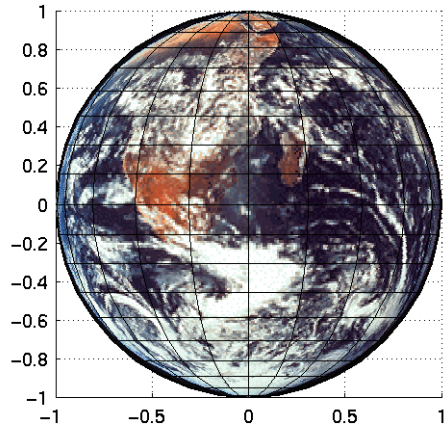

# Defining the View

---

<b>Setting the Viewpoint</b> . . . . .	11-3
<b>Defining Scenes with Camera Graphics</b> . . . . .	11-7
<b>View Control with the Camera Toolbar</b> . . . . .	11-8
<b>Camera Graphics Functions</b> . . . . .	11-20
<b>Dollying the Camera</b> . . . . .	11-21
<b>Moving the Camera Through a Scene</b> . . . . .	11-23
<b>Low-Level Camera Properties</b> . . . . .	11-29
<b>View Projection Types</b> . . . . .	11-35
<b>Understanding Axes Aspect Ratio</b> . . . . .	11-40
<b>Axes Aspect Ratio Properties</b> . . . . .	11-45

## View Definition Topics

The *view* is the particular orientation you select to display your graph or graphical scene. The term viewing refers to the process of displaying a graphical scene from various directions, zooming in or out, changing the perspective and aspect ratio, flying by, and so on.

This section describes how to define the various viewing parameters to obtain the view you want. Generally, viewing is applied to 3-D graphs or models, although you may want to adjust the aspect ratio of 2-D views to achieve specific proportions or make a graph fit in a particular shape.

MATLAB viewing is composed of two basic areas:

- Positioning the viewpoint to orient the scene
- Setting the aspect ratio and relative axis scaling to control the shape of the objects being displayed

### Positioning the Viewpoint

- **Setting the Viewpoint** – discusses how to specify the point from which you view a graph in terms of azimuth and elevation. This is conceptually simple, but does have limitations.
- **Defining Scenes with Camera Graphics, View Control with the Camera Toolbar, and Camera Graphics Functions** – describes how to compose complex scenes using MATLAB's camera viewing model.
- **Dollying the Camera and Moving the Camera Through a Scene** – illustrate programming techniques for moving the view around and through scenes.
- **Low-Level Camera Properties** – lists the graphics properties that control the camera and illustrates the effects they cause.

### Setting the Aspect Ratio

- **View Projection Types** – discusses orthographic and perspective projection types and illustrates their use.
- **Understanding Axes Aspect Ratio and Axes Aspect Ratio Properties** – describes how MATLAB sets the aspect ratio of the axes and how you can select the most appropriate setting for your graphs.

**MATLAB automatically sets the view when you create a graph. The actual view that MATLAB selects depends on whether you are creating a 2- or 3-D graph. See the Default Viewpoint Selection and Default Aspect Ratio Selection sections in this chapter for a description of how MATLAB defines the standard view.**

## Setting the Viewpoint

MATLAB enables you to control the orientation of the graphics displayed in an axes. You can specify the viewpoint, view target, orientation, and extent of the view displayed in a figure window. These viewing characteristics are controlled by a set of graphics properties. You can specify values for these properties directly or use the `view` command to select a view direction and rely on MATLAB's automatic property selection to define a reasonable view.

### Specifying Azimuth and Elevation

The `view` command specifies the viewpoint by defining azimuth and elevation with respect to the axis origin. Azimuth is a polar angle in the  $x$ - $y$  plane, with positive angles indicating counter-clockwise rotation of the viewpoint. Elevation is the angle above (positive angle) or below (negative angle) the  $x$ - $y$  plane.

This diagram illustrates the coordinate system. The arrows indicate positive directions.

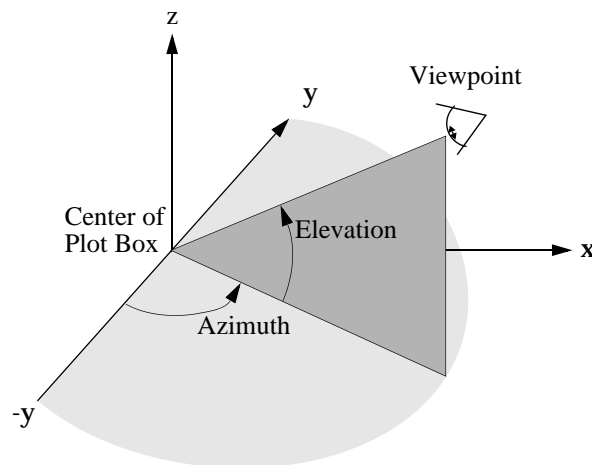

MATLAB automatically selects a viewpoint that is determined by whether the plot is 2-D or 3-D:

- For 2-D plots, the default is azimuth =  $0^\circ$  and elevation =  $90^\circ$ .



- For 3-D plots, the default is azimuth =  $-37.5^\circ$  and elevation =  $30^\circ$ .

For example, these statements create a 3-D surface plot and display it in the default 3-D view.

```
[X,Y] = meshgrid([-2:.25:2]);  
Z = X.*exp(-X.^2 -Y.^2);  
surf(X,Y,Z)
```

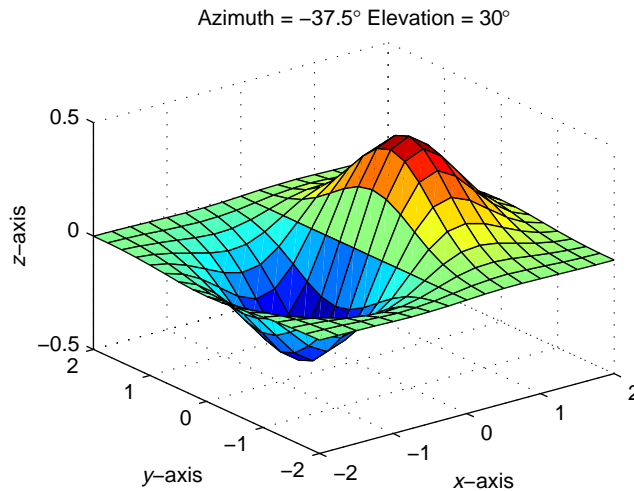

The statement

```
view([180 0])
```

sets the viewpoint so you are looking in the negative  $y$ -direction with your eye at the  $z = 0$  elevation.

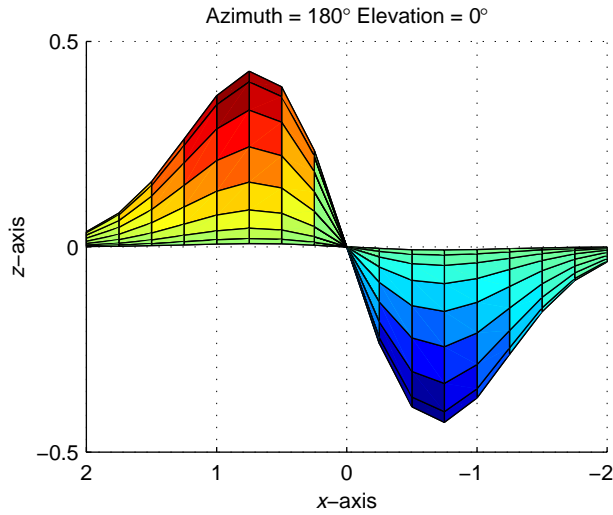

You can move the viewpoint to a location below the axis origin using a negative elevation.

```
view([-37.5 -30])
```

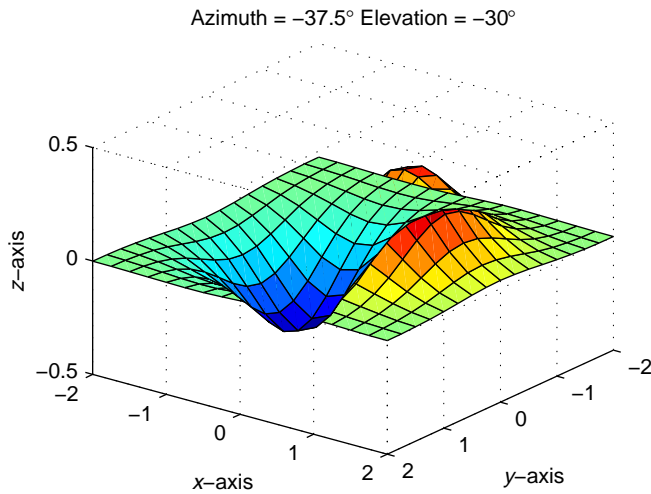

### **Limitations of Azimuth and Elevation**

Specifying the viewpoint in terms of azimuth and elevation is conceptually simple, but it has limitations. It does not allow you to specify the actual position of the viewpoint, just its direction, and the  $z$ -axis is always pointing up. It does not allow you to zoom in and out on the scene or perform arbitrary rotations and translations.

MATLAB's camera graphics provides greater control than the simple adjustments allowed with azimuth and elevation. The following sections discusses how to use camera properties to control the view.

## Defining Scenes with Camera Graphics

When you look at the graphics objects displayed in an axes, you are viewing a scene from a particular location in space that has a particular orientation with regard to the scene. MATLAB provides functionality, analogous to that of a camera with a zoom lens, that enables you to control the view of the scene created by MATLAB.

This picture illustrates how the camera is defined in terms of properties of the axes.

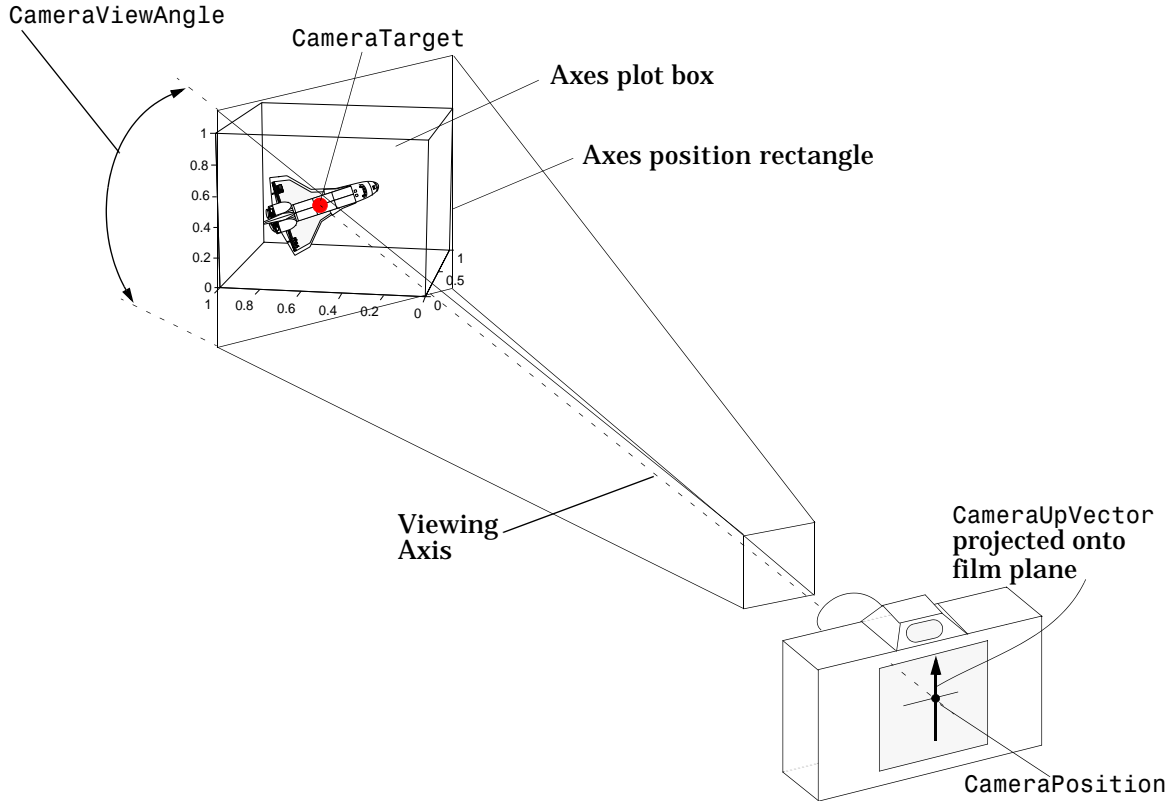

## View Control with the Camera Toolbar

The Camera Toolbar enables you to perform a number of viewing operations interactively. To use the Camera Toolbar:

- Display the toolbar by selecting **Camera Toolbar** from the figure window's **View** menu.
- Select the type of camera motion control you want to use.
- Position the cursor over the figure window and click, hold down the right mouse button, then move the cursor in the desired direction.

MATLAB updates the display immediately as you move the mouse.

### Camera Toolbar

The toolbar contains the following parts:

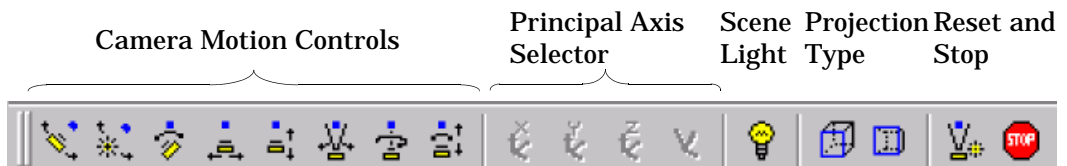

- **Camera Motion Controls** – these tools select which camera motion function to enable. You can also access the camera motion controls from the **Tools** menu.
- **Principal Axis Selector** – some camera controls operate with respect to a particular axis. These selectors enable you to select the principal axis or to select non-axis constrained motion. The selectors are grayed out when not applicable to the currently selected function. You can also access the principal axis selector from the **Tools** menu.
- **Scene Light** – The scene light button toggles a light source on or off in the scene (one light per axes).
- **Projection Type** – You can select orthographic or perspective projection types.
- **Reset and Stop** – Reset returns the scene to the standard 3-D view. Stop causes the camera to stop moving (this can be useful if you apply too much

cursor movement). You can also access the an expanded set of reset functions from the **Tools** menu.

### Principal Axes

The principal axis of a scene defines the direction that is oriented upward on the screen. For example, a MATLAB surface plot aligns the up direction along the positive z axis.

Principal axes constrain camera-tool motion along axes that are (on the screen) parallel and perpendicular to the principal axis that you select. Specifying a principal axis is useful if your data is define with respect to a specific axis. Z is the default principal axis, since this matches MATLAB's default 3-D view.

Three of the camera tools (Orbit, Pan/Tilt, and Walk) allow you to select a principal axis, as well as axis-free motion. On the screen, the axes of rotation are determined by a vertical and a horizontal line, both of which pass through the point defined by the `CameraTarget` property and are parallel and perpendicular to the principal axis.

For example, when the principal axis is z, movement occurs about:

- A vertical line that passes through the camera target and is parallel to the z axis
- A horizontal line that passes through the camera target and is perpendicular to the z axis

This means the scene (or camera, as the case may be) moves in an arc whose center is at the camera target. The following picture illustrates the rotation axes for a z principal axis.

Horizontal cursor motion results in rotation about the (blue) vertical axis.

Vertical cursor motion causes rotation about the (red) horizontal axis.

Cursor Motion

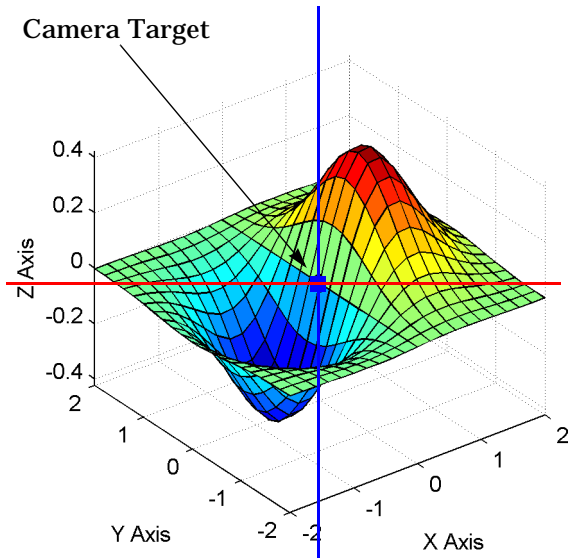

Z Principal axis

The axes of rotation always pass through the camera target.

### Optimizing for 3-D Camera Motion

When you create a plot, MATLAB displays it with an aspect ratio that fits the figure window. This behavior may not create an optimum situation for the manipulation of 3-D graphics as it can lead to distortion as you move the camera around scene. To avoid possible distortion, it is best to switch to a 3-D visualization mode (enabled from the command line with the command `axis vis3d`). When using the camera toolbar, MATLAB automatically switches to the 3-D visualization mode, but warns you first with the following dialog box.





**Graphics Properties.** Orbit camera changes the `CameraPosition` property while keeping the `CameraTarget` fixed.

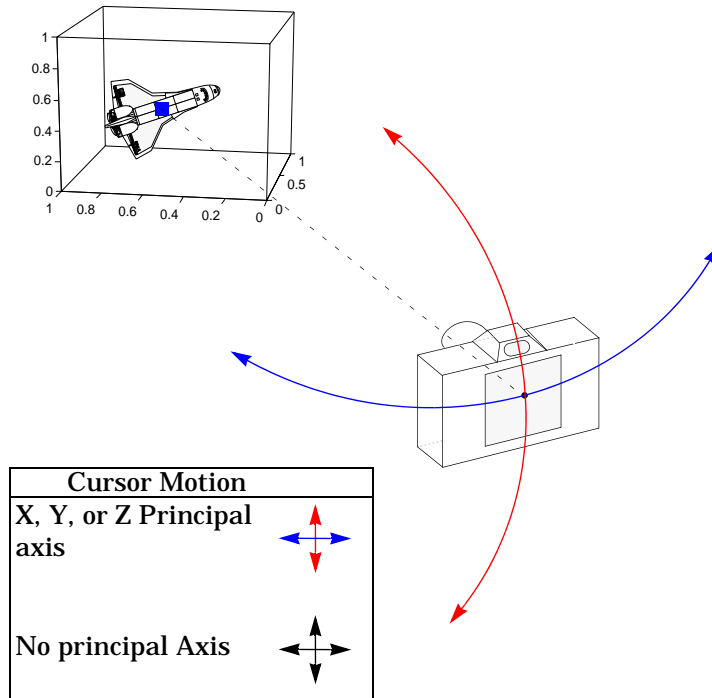

## Orbit Scene Light



The scene light is a light source that is placed with respect to the camera position. By default, the scene light is positioned to the right of the camera (i.e., `camlight right`). Orbit Scene Light changes the light's offset from the camera position. There is only one scene light, however, you can add other lights using the light command.

Toggle the scene light on and off by clicking on the yellow light bulb icon.

Graphics Properties. Orbit Scene Light moves the scene light by changing the light's Position property.

## Pan/Tilt Camera



Pan/Tilt Camera moves the point in the scene that the camera points to while keeping the camera fixed. The movement occurs in an arc about the z-axis by default. You can select x-, y-, z-, or free-axis rotation using the Principal Axes Selectors.

Graphics Properties. Pan/Tilt Camera moves the point in the scene that the camera is pointing to by changing the CameraTarget property.

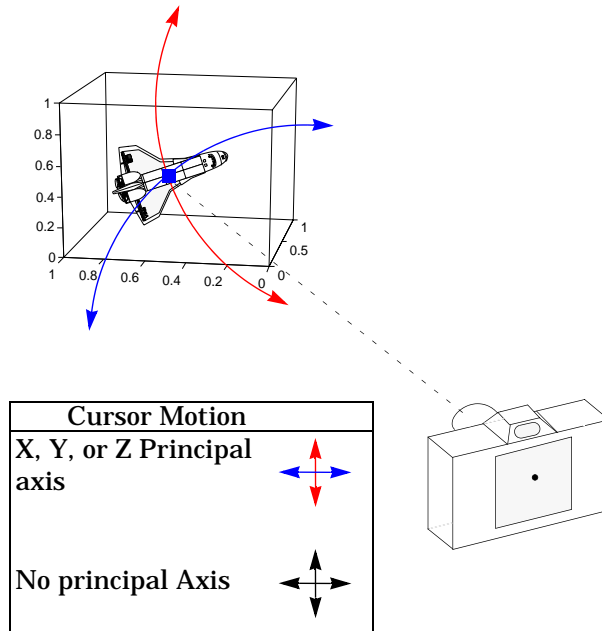

## Move Camera Horizontally/Vertically



Moving the cursor horizontally or vertically (or any combination of the two) moves the scene in the same direction.

Graphics Properties. The horizontal and vertical movement is achieved by moving the `CameraPosition` and the `CameraTarget` in unison along parallel lines.

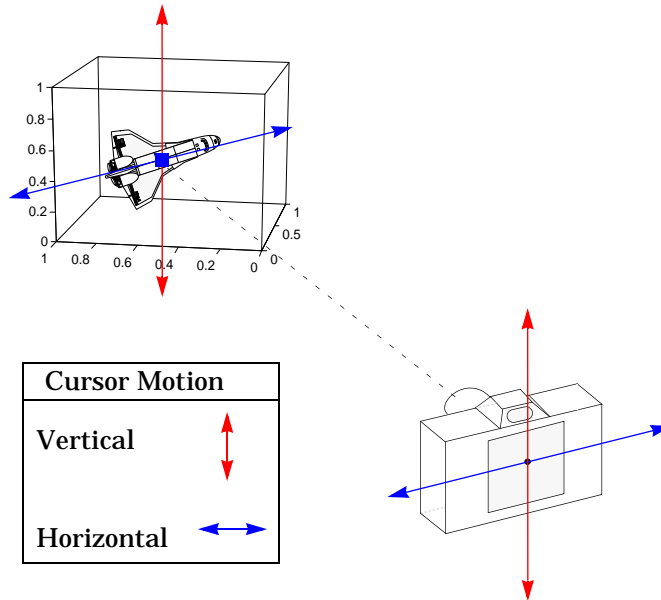

## Move Camera Forward and Backwards



Moving the cursor up or to the right moves the camera towards the scene.  
 Moving the cursor down or to the left moves the camera away from the scene.  
 It is possible to move the camera through objects in the scene and to the other side of the camera target.

**Graphics Properties.** This function moves the `CameraPosition` along the line connecting the camera position and the camera target.

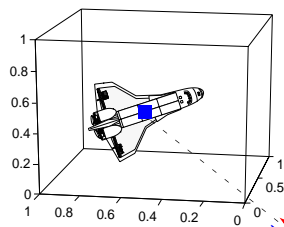

Cursor Motion	
Closer to target	
Farther from target	

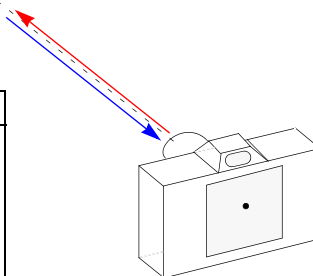

## Zoom Camera

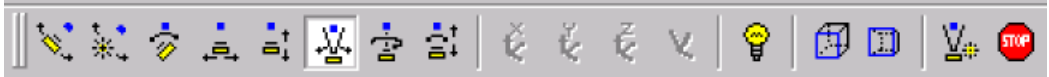

Zoom Camera makes the scene larger as you move the cursor up or to the right and smaller as you move the cursor down or to the left. Zooming does not move the camera and therefore cannot move the viewpoint through objects in the scene.

Graphics Properties. Zoom is implemented by changing the `CameraViewAngle`. The larger the angle, the smaller the scene appears, and vice versa.

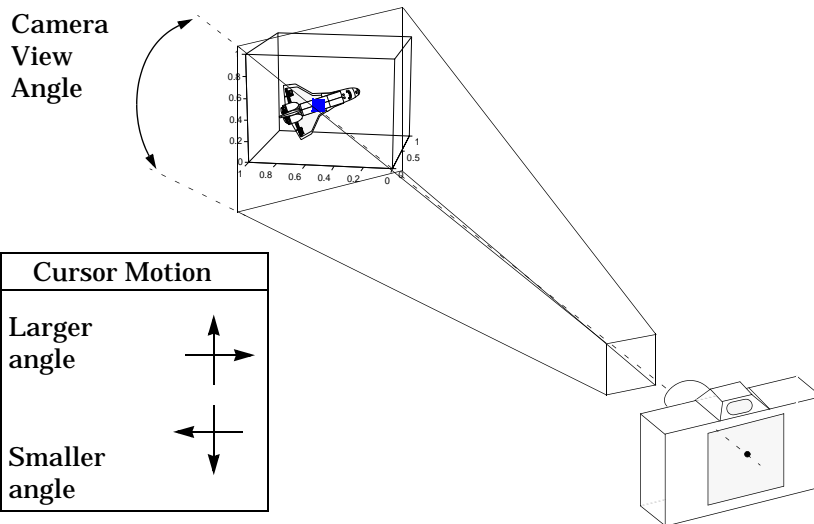

## Camera Roll



Camera Roll rotates the camera about the viewing axis, thereby rotating the view on the screen.

Graphics Properties. Camera Roll changes the CameraUpVector

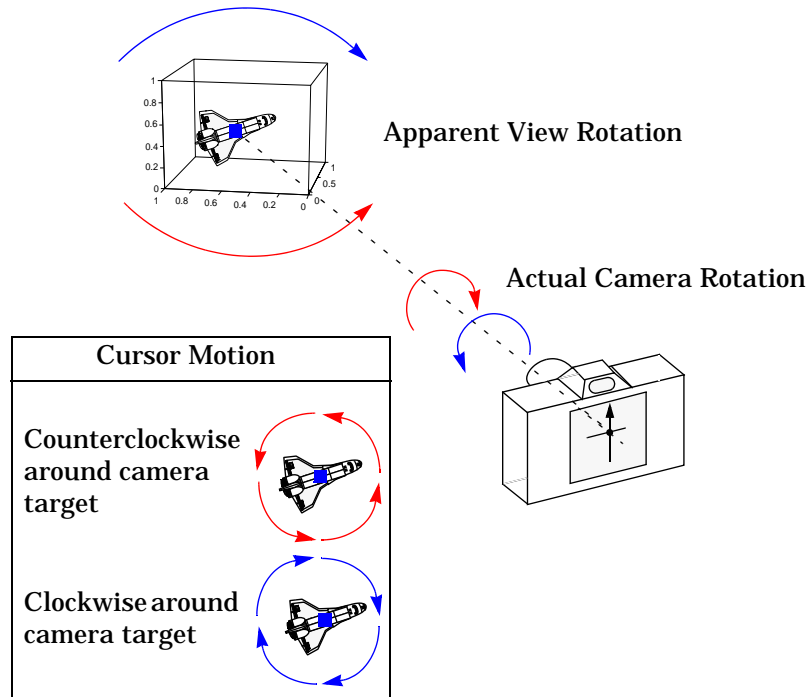



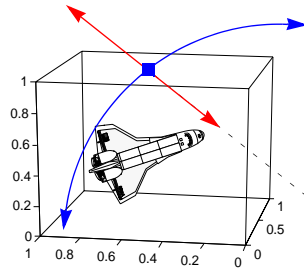

Cursor Motion	
Towards or away from scene	↕
Pan left or right	↔

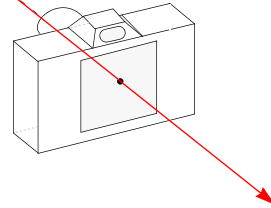



## Camera Graphics Functions

The following table lists MATLAB functions that enable you to perform a number of useful camera maneuvers. The individual command descriptions provide information on using each one.

<b>Functions</b>	<b>Purpose</b>
camdolly	Move camera position and target
camlookat	View specific objects
camorbit	Orbit the camera about the camera target
campan	Rotate the camera target about the camera position
campos	Set or get the camera position
camproj	Set or get the projection type (orthographic or perspective)
camroll	Rotate the camera about the viewing axis
camtarget	Set or get the camera target location
camup	Set or get the value of the camera up vector
camva	Set or get the value of the camera view angle
camzoom	Zoom the camera in or out on the scene

## Dollying the Camera

In the camera metaphor, a dolly is a stage that enables movement of the camera side to side with respect to the scene. The `camdolly` command implements similar behavior by moving both the position of the camera and the position of the camera target in unison (or just the camera position if you so desire).

This example illustrates how to use `camdolly` to explore different regions of an image.

### Summary of Techniques

This example:

- Uses `ginput` to obtain the coordinates of locations on the image
- Uses the `camdolly data coordinates` option to move the camera and target to the new position based on coordinates obtained from `ginput`
- Uses `camva` to zoom in and to fix the camera view angle, which is otherwise under automatic control

### Implementation

First load the Cape Cod image and zoom in by setting the camera view angle (using `camva`).

```
load cape
image(X)
colormap(map)
axis image
camva(camva/2.5)
```

Then use `ginput` to select the  $x$ - and  $y$ -coordinates of the camera target and camera position.

```
while 1
    [x,y] = ginput(1);
    if ~strcmp(get(gcf, 'SelectionType'), 'normal')
        break
    end
    ct = camtarget;
    dx = x - ct(1);
```

```
dy = y - ct(2);  
camdolly(dx,dy,ct(3),'movetarget','data')  
drawnow  
end
```

## Moving the Camera Through a Scene

A fly-through is an effect created by moving the camera through three dimensional space, giving the impression that you are flying along with the camera as if in an aircraft. You can fly-through of regions of a scene that may be otherwise obscured by objects in the scene or you can fly by a scene by keeping the camera focused on a particular point.

To accomplish these effects you move the camera along a particular path, the x axis for example, in a series of steps. To produce a fly-through, move both the camera position and the camera target at the same time.

The following example makes use of the fly-through effect to view the interior of an isosurface drawn within a volume defined by a vector field of wind velocities. This data representing air currents over North America.

See `coneplot` for a fixed visualization of the same data.

### Summary of Techniques

This example employs a number of visualization techniques. It uses:

- Isosurfaces and `conplots` to illustrate the flow through the volume
- Lighting to illuminate the isosurface and cones in the volume
- Stream lines to define a path for the camera through the volume
- Coordinated motion of the camera position, camera target, and light together

### Graphing the Volume Data

The first step is to draw the isosurface and plot the air flow using cone plots.

See `isosurface`, `isonormals`, `reducepatch`, and `coneplot` for information on using these commands.

Setting the data aspect ratio (`daspect`) to `[1, 1, 1]` before drawing the cone plot enables MATLAB to calculate the size of the cones correctly for the final view.

```
load wind
wind_speed = sqrt(u.^2 + v.^2 + w.^2);

hpatch = patch(isosurface(x,y,z,wind_speed,35));
isonormals(x,y,z,wind_speed,hpatch)
```

```

set(hpatch, 'FaceColor', 'red', 'EdgeColor', 'none');

[f vt] = reducepatch(isosurface(x,y,z,wind_speed,45),0.05);
daspect([1,1,1]);
hcone = coneplot(x,y,z,u,v,w,vt(:,1),vt(:,2),vt(:,3),2);
set(hcone, 'FaceColor', 'blue', 'EdgeColor', 'none');

```

## Setting Up the View

You need to define viewing parameters to ensure the scene displays correctly.

- Selecting a perspective projection provides the perception of depth as the camera passes through the interior of the isosurface (`camproj`).
- Setting the camera view angle to a fixed value prevents MATLAB from automatically adjusting the angle to encompass the entire scene as well as zooming in to the desired amount (`camva`).

```

camproj perspective
camva(25)

```

## Specifying the Light Source

Positioning the light source at the camera location and modifying the reflectance characteristics of the isosurface and cones enhances the realism of the scene.

- Creating a light source at the camera position provides a “headlight” that moves along with the camera through the isosurface interior (`camlight`).
- Setting the reflection properties of the isosurface gives the appearance of a dark interior (`AmbientStrength` set to 0.1) with highly reflective material (`SpecularStrength` and `DiffuseStrength` set to 1).
- Setting the `SpecularStrength` of the cones to 1 makes them highly reflective.

```

hlight = camlight('headlight');
set(hpatch, 'AmbientStrength', .1, ...
    'SpecularStrength', 1, ...
    'DiffuseStrength', 1);
set(hcone, 'SpecularStrength', 1);
set(gcf, 'Color', 'k')

```

## Selecting a Renderer

Because this example uses lighting, MATLAB must use either `zbuffer` or, if available, OpenGL renderer settings. The OpenGL renderer is likely to be much faster displaying the animation; however, you need to use `gouraud` lighting with OpenGL, which is not as smooth as `phong` lighting, which you can use with the `zbuffer` renderer. The two choices are

```
lighting gouraud
set(gcf, 'Renderer', 'OpenGL')
```

or for `zbuffer`

```
lighting phong
set(gcf, 'Renderer', 'zbuffer')
```

## Defining the Camera Path as a Stream Line

Stream lines indicate the direction of flow in the vector field. This example uses the `x`, `y`, and `z` coordinate data of a single stream line to map a path through the volume. The camera is then moved along this path. The steps include:

- Create a stream line starting at the point `x = 80`, `y = 30`, `z = 11`
- Get the `x`, `y`, and `z` coordinate data of the stream line.
- Delete the stream line (note that you could also use `stream3` to calculate the stream line data without actually drawing the stream line).

```
hsline = streamline(x,y,z,u,v,w,80,30,11);
xd = get(hsline, 'XData');
yd = get(hsline, 'YData');
zd = get(hsline, 'ZData');
delete(hsline)
```

## Implementing the Fly-Through

To create a fly-through, move the camera position and camera target along the same path. In this example, the camera target is placed five elements further along the `x`-axis than the camera. Also, a small value is added to the camera target `x` position to prevent the position of the camera and target from becoming the same point if the condition `xd(n) = xd(n+5)` should occur:

- Update the camera position and camera target so that they both move along the coordinates of the stream line.
- Move the light along with the camera.
- Call drawnow to display the results of each move.

```
for i=1:length(xd)-50
    campos([xd(i),yd(i),zd(i)])
    camtarget([xd(i+5)+min(xd)/100,yd(i),zd(i)])
    camlight(hlight,'headlight')
    drawnow
end
```

These snapshots illustrate the view at values of  $i$  equal to 10, 110, and 185.

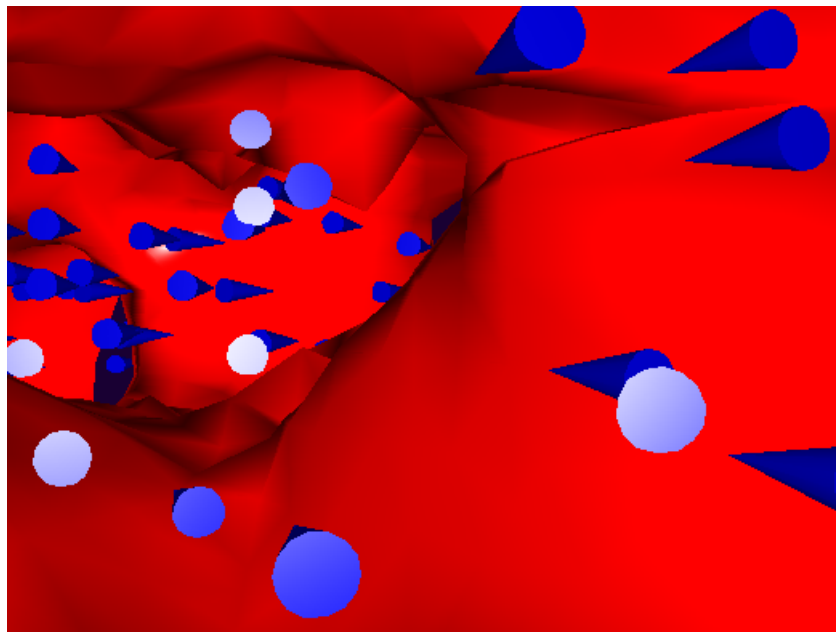

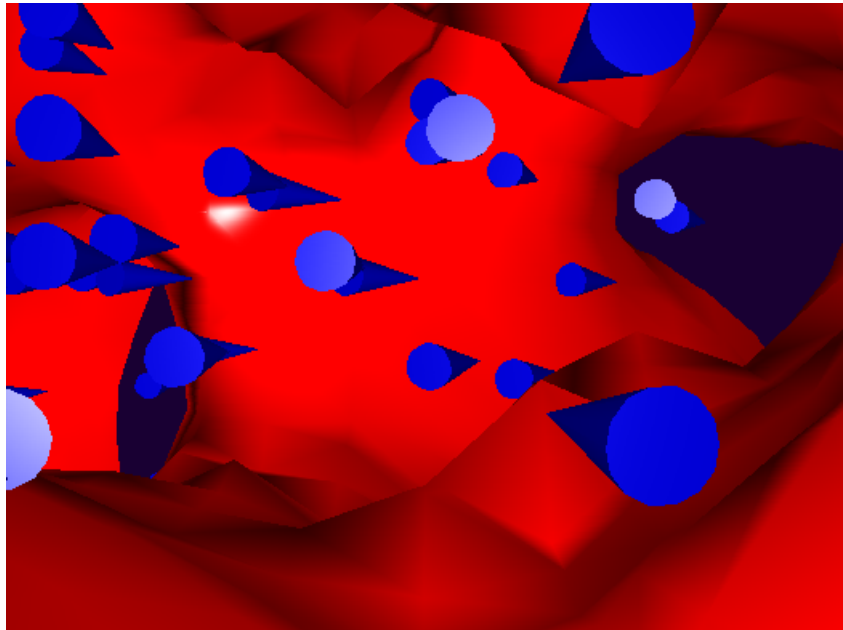



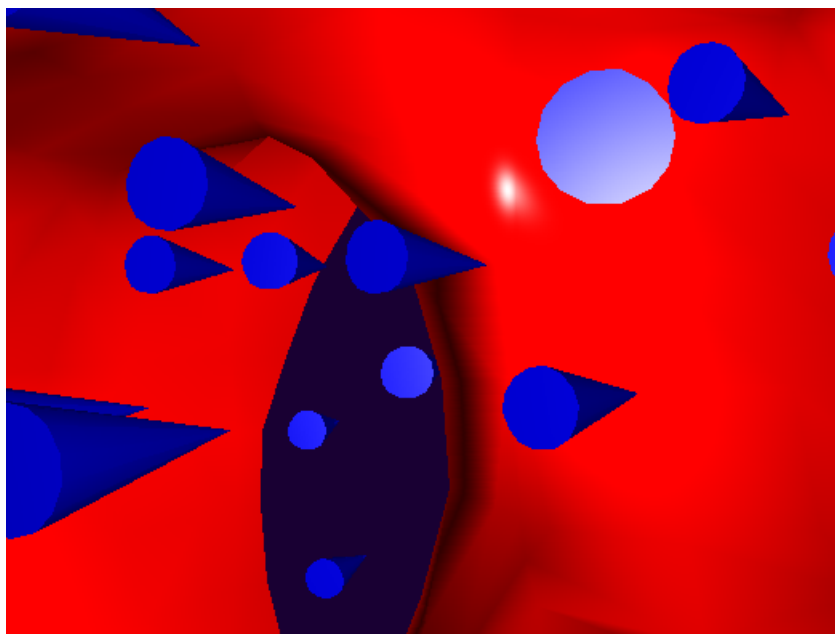

## Low-Level Camera Properties

Camera graphics is based on a group of axes properties that control the position and orientation of the camera. In general, the camera commands make it unnecessary to access these properties directly.

Property	What It Is
CameraPosition	Specifies the location of the viewpoint in axes units.
CameraPositionMode	In automatic mode, MATLAB determines the position based on the scene. In manual mode, you specify the viewpoint location.
CameraTarget	Specifies the location in the axes that the camera points to. Together with the CameraPosition, it defines the viewing axis.
CameraTargetMode	In automatic mode, MATLAB specifies the CameraTarget as the center of the axes plot box. In manual mode, you specify the location.
CameraUpVector	The rotation of the camera around the viewing axis is defined by a vector indicating the direction taken as up.
CameraUpVectorMode	In automatic mode, MATLAB orients the up vector along the positive $y$ -axis for 2-D views and along the positive $z$ -axis for 3-D views. In manual mode, you specify the direction.
CameraViewAngle	Specifies the field of view of the “lens.” If you specify a value for CameraViewAngle, MATLAB overrides stretch-to-fill behavior (see the “Understanding Axes Aspect Ratio” section of this chapter).
CameraViewAngleMode	In automatic mode, MATLAB adjusts the view angle to the smallest angle that captures the entire scene. In manual mode, you specify the angle.  Setting CameraViewAngleMode to manual overrides stretch-to-fill behavior.
Projection	Selects either an orthographic or perspective projection.

## Default Viewpoint Selection

When all the camera mode properties are set to auto (the default), MATLAB automatically controls the view, selecting appropriate values based on the assumption that you want the scene to fill the position rectangle (which is defined by the width and height components of the axes `Position` property).

By default, MATLAB:

- Sets the `CameraPosition` so the orientation of the scene is the standard MATLAB 2-D or 3-D view (see the `view` command)
- Sets the `CameraTarget` to the center of the plot box
- Sets the `CameraUpVector` so the *y*-direction is up for 2-D views and the *z*-direction is up for 3-D views
- Sets the `CameraViewAngle` to the minimum angle that makes the scene fill the position rectangle (the rectangle defined by the axes `Position` property)
- Uses orthographic projection

This default behavior generally produces desirable results. However, you can change these properties to produce useful effects.

## Moving In and Out on the Scene

You can move the camera anywhere in the 3-D space defined by the axes. The camera continues to point towards the target regardless of its position. When the camera moves, MATLAB varies the camera view angle to ensure the scene fills the position rectangle.

### Moving Through a Scene

You can create a fly-by effect by moving the camera through the scene. To do this, continually change `CameraPosition` property, moving it toward the target. Since the camera is moving through space, it turns as it moves past the camera target. Override MATLAB's automatic resizing of the scene each time you move the camera by setting the `CameraViewAngleMode` to `manual`.

If you update the `CameraPosition` and the `CameraTarget`, the effect is to pass through the scene while continually facing the direction of movement.

If the `Projection` is set to `perspective`, the amount of perspective distortion increases as the camera gets closer to the target and decreases as it gets farther away.

### Example – Moving Toward or Away from the Target

To move the camera along the viewing axis, you need to calculate new coordinates for the `CameraPosition` property. This is accomplished by subtracting (to move closer to the target) or adding (to move away from the target) some fraction of the total distance between the camera position and the camera target.

The function `movecamera` calculates a new `CameraPosition` that moves in on the scene if the argument `dist` is positive and moves out if `dist` is negative.

```
function movecamera(dist) %dist in the range [-1 1]
set(gca,'CameraViewAngleMode','manual')
newcp = cpos - dist * (cpos - ctarg);
set(gca,'CameraPosition',newcp)
function out = cpos
out = get(gca,'CameraPosition');
function out = ctarg
out = get(gca,'CameraTarget');
```

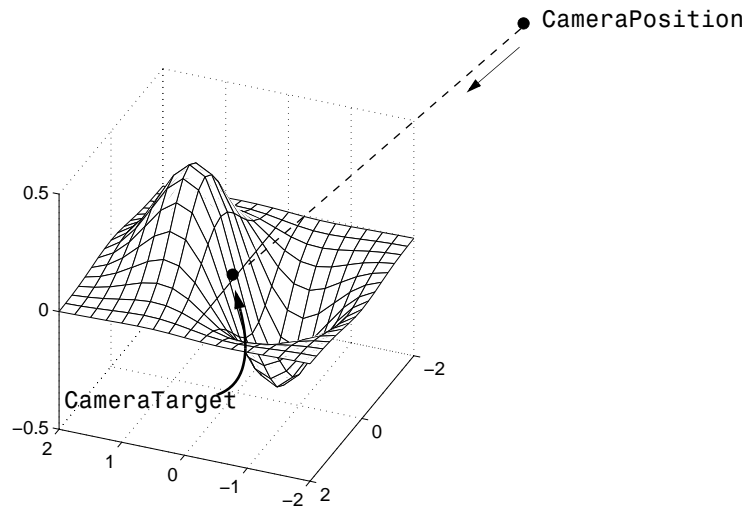

Note that setting the `CameraViewAngleMode` to `manual` overrides MATLAB's stretch-to-fill behavior and may cause an abrupt change in the aspect ratio. See

the “Understanding Axes Aspect Ratio” section of this chapter for more information on stretch-to-fill.

## Making the Scene Larger or Smaller

Adjusting the `CameraViewAngle` property makes the view of the scene larger or smaller. Larger angles cause the view to encompass a larger area, thereby making the objects in the scene appear smaller. Similarly, smaller angles make the objects appear larger.

Changing `CameraViewAngle` makes the scene larger or smaller without affecting the position of the camera. This is desirable if you want to zoom in without moving the viewpoint past objects that will then no longer be in the scene (as could happen if you changed the camera position). Also, changing the `CameraViewAngle` does not affect the amount of perspective applied to the scene, as changing `CameraPosition` does when the figure `Projection` property is set to perspective.

## Revolving Around the Scene

You can use the `view` command to revolve the viewpoint about the  $z$ -axis by varying the azimuth, and about the azimuth by varying the elevation. This has the effect of moving the camera around the scene along the surface of a sphere whose radius is the length of the viewing axis. You could create the same effect by changing the `CameraPosition`, but doing so requires you to perform calculations that MATLAB performs for you when you call `view`.

For example, the function `orbit` moves the camera around the scene.

```
function orbit(deg)
[az el] = view;
rotvec = 0:deg/10:deg;
for i = 1:length(rotvec)
    view([az+rotvec(i) el])
    drawnow
end
```

## Rotation Without Resizing of Graphics Objects

When `CameraViewAngleMode` is `auto`, MATLAB calculates the `CameraViewAngle` so that the scene is as large as can fit in the axes position rectangle. This causes an apparent size change during rotation of the scene. To

prevent resizing during rotation, you need to set the `CameraViewAngleMode` to `manual` (which happens automatically when you specify a value for the `CameraViewAngle` property). To do this in the `orbit` function, add the statement

```
set(gca, 'CameraViewAngleMode', 'manual')
```

## Rotation About the Viewing Axis

You can change the orientation of the scene by specifying the direction defined as *up*. By default, MATLAB defines *up* as the *y*-axis in 2-D views (the `CameraUpVector` is `[0 1 0]`) and the *z*-axis for 3-D views (the `CameraUpVector` is `[0 0 1]`). However, you can specify *up* as any arbitrary direction.

The vector defined by the `CameraUpVector` property forms one axis of the camera's coordinate system. Internally, MATLAB determines the actual orientation of the camera up vector by projecting the specified vector onto the plane that is normal to the camera direction (i.e., the viewing axis). This simplifies the specification of the `CameraUpVector` property since it need not lie in this plane.

In many cases, you may find it convenient to visualize the desired up vector in terms of angles with respect to the axes *x*-, *y*-, and *z*-axes. You can then use *direction cosines* to convert from angles to vector components. For a unit vector, the expression simplifies to

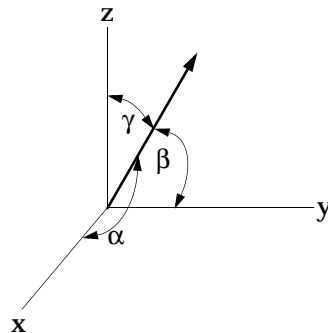

where the angles  $\alpha$ ,  $\beta$ , and  $\gamma$  are specified in degrees.

```
XComponent = cos( $\alpha \times (\text{pi} \div 180)$ );  
YComponent = cos( $\beta \times (\text{pi} \div 180)$ );  
ZComponent = cos( $\gamma \times (\text{pi} \div 180)$ );
```

(Consult a mathematics book on vector analysis for a more detailed explanation of direction cosines.)

### Example – Calculating a Camera Up Vector

To specify an up vector that makes an angle of  $30^\circ$  with the  $z$ -axis and lies in the  $y$ - $z$  plane, use the expression

```
upvec = [cos( $90 \times (\text{pi}/180)$ ), cos( $60 \times (\text{pi}/180)$ ), cos( $30 \times (\text{pi}/180)$ )];
```

and then set the CameraUpVector property.

```
set(gca, 'CameraUpVector', upvec)
```

Drawing a sphere with this orientation produces

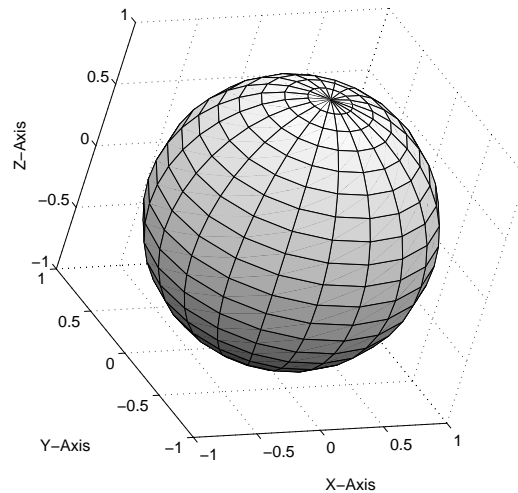

## View Projection Types

MATLAB supports both orthographic and perspective projection types for displaying 3-D graphics. The one you select depends on the type of graphics you are displaying:

- orthographic projects the viewing volume as a rectangular parallelepiped (i.e., a box whose opposite sides are parallel). Relative distance from the camera does not affect the size of objects. This projection type is useful when it is important to maintain the actual size of objects and the angles between objects.
- perspective projects the viewing volume as the frustrum of a pyramid (a pyramid whose apex has been cut off parallel to the base). Distance causes foreshortening; objects further from the camera appear smaller. This projection type is useful when you want to display realistic views of real objects.

By default, MATLAB displays objects using orthographic projection. You can set the projection type using the `camproj` command.

These pictures show a drawing of a dump truck (created with `patch`) and a surface plot of a mathematical function, both using orthographic projection.

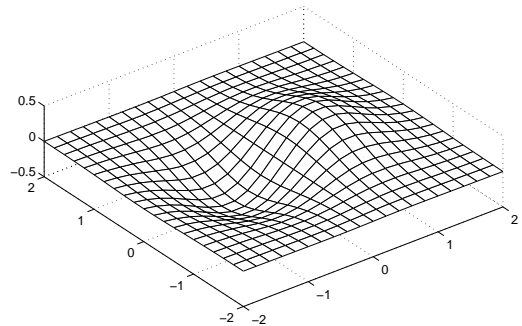
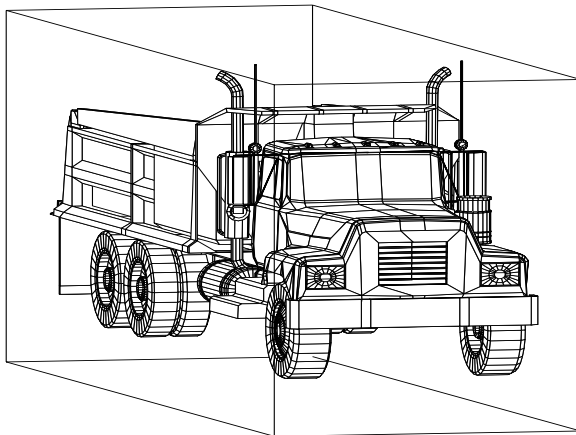



If you measure the width of the front and rear faces of the box enclosing the dump truck, you'll see they are the same size. This picture looks unnatural because it lacks the apparent perspective you see when looking at real objects with depth. On the other hand, the surface plot accurately indicates the values of the function within rectangular space.

Now look at the same graphics objects with perspective added. The dump truck looks more natural because portions of the truck that are farther from the viewer appear smaller. This projection mimics the way human vision works. The surface plot, on the other hand, looks distorted.

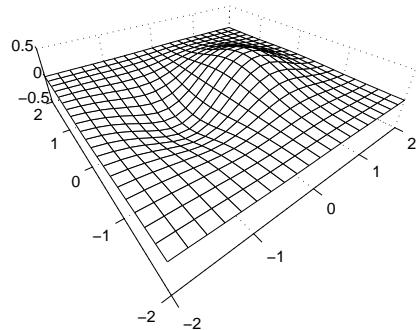
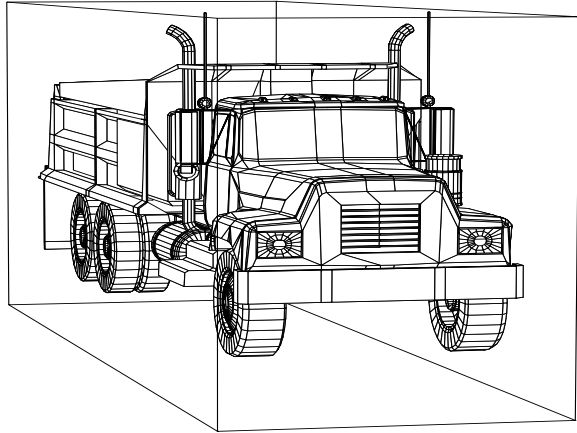

## Projection Types and Camera Location

By default, MATLAB adjusts the `CameraPosition`, `CameraTarget`, and `CameraViewAngle` properties to point the camera at the center of the scene and to include all graphics objects in the axes. If you position the camera so that there are graphics objects behind the camera, the scene displayed can be affected by both the axes `Projection` property and the figure `Renderer`

property. This table summarizes the interactions between projection type and rendering method.

	Orthographic	Perspective
Z-buffer	CameraViewAngle determines extent of scene at CameraTarget	CameraViewAngle determines extent of scene from CameraPosition to infinity
Painters	All objects display regardless of CameraPosition	Not recommended if graphics objects are behind the CameraPosition

This diagram illustrates what you see (gray area) when using orthographic projection and Z-buffer. Anything in front of the camera is visible.

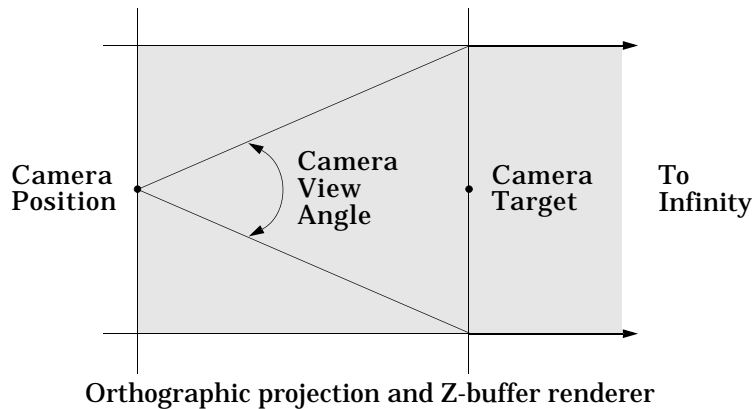

In perspective projection, you see only what is visible in the cone of the camera view angle.

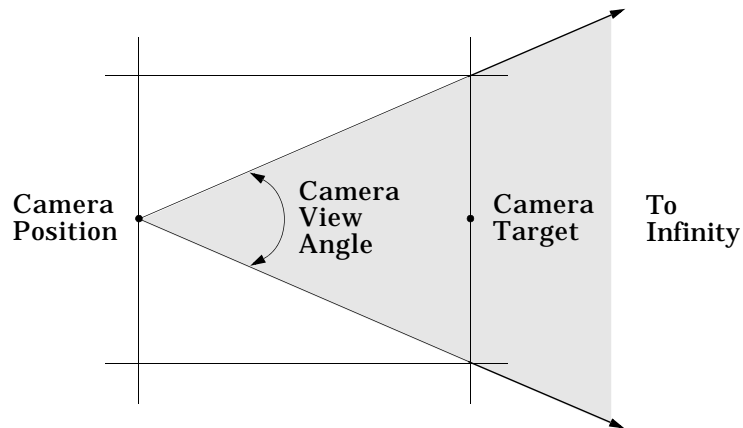

Perspective projection and Z-buffer renderer

Painters rendering method is less suited to moving the camera in 3-D space because MATLAB does not clip along the viewing axis. Orthographic projection in painters method results in all objects contained in the scene being visible regardless of the camera position.

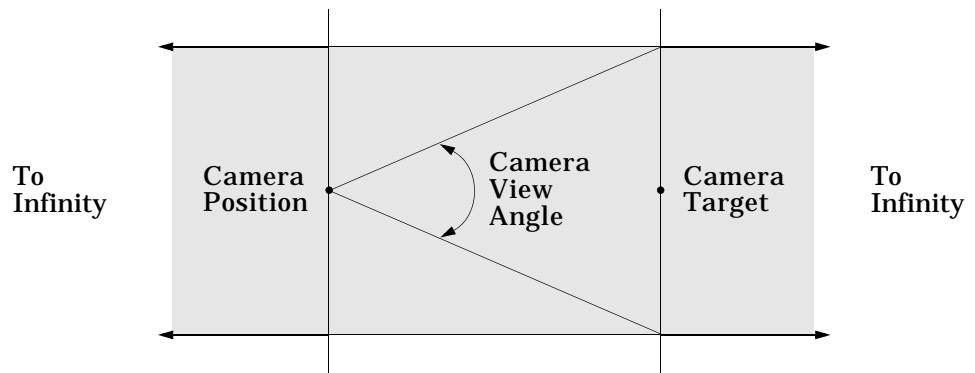

Orthographic projection and painters renderer

### Printing 3-D Scenes

The same effects described in the previous section occur in hardcopy output. However, because of the differences in the process of rendering to the screen

and to a printing format, MATLAB may render in Z-buffer and generate printed output in painters. You may need to specify Z-buffer printing explicitly to obtain the results displayed on the screen (use the `-zbuffer` option with the `print` command).

### **Additional Information**

See the “Basic Printing and Exporting” chapter and the “Selecting a Renderer” section in the “Figure Properties” chapter for information on printing and rendering methods.

## Understanding Axes Aspect Ratio

Axes shape graphics objects by setting the scaling and limits of each axis. When you create a graph, MATLAB automatically determines axis scaling based on the values or size of the plotted data, and then draws the axes to fit the space available for display. Axes aspect ratio properties control how MATLAB performs the scaling required to create a graph.

This section discusses MATLAB's default behavior as well as techniques for customizing graphs.

### Stretch-to-Fill

By default, the size of the axes MATLAB creates for plotting is normalized to the size of the figure window (but is slightly smaller to allow for borders). If you resize the figure, the size and possibly the aspect ratio (the ratio of width to height) of the axis changes proportionally. This enables the axes to always fill the available space in the window. MATLAB also sets the  $x$ -,  $y$ -, and  $z$ -axis limits to provide the greatest resolution in each direction, again optimizing the use of available space.

This stretch-to-fill behavior is generally desirable; however, you may want to control this process to produce specific results. For example, images need to be displayed in correct proportions regardless of the aspect ratio of the figure window, or you may want graphs always to be a particular size on a printed page.

### Specifying Axis Scaling

The `axis` command enables you to adjust the scaling of graphs. By default, MATLAB finds the maxima and minima of the plotted data and chooses appropriate axes ranges. You can override the defaults by setting axis limits.

```
axis([xmin xmax ymin ymax zmin zmax])
```

You can control how MATLAB scales the axes with predefined axis options:

- `axis auto` returns the axis scaling to its default, automatic mode. `v = axis` saves the scaling of the axes of the current plot in vector `v`. For subsequent graphics commands to have these same axis limits, follow them with `axis(v)`.

- `axis manual` freezes the scaling at the current limits. If you then set `hold on`, subsequent plots use the current limits. Specifying values for axis limits also sets axis scaling to manual.
- `axis tight` sets the axis limits to the range of the data.
- `axis ij` places MATLAB into its “matrix” axes mode. The coordinate system origin is at the upper-left corner. The *i*-axis is vertical and is numbered from top to bottom. The *j*-axis is horizontal and is numbered from left to right.
- `axis xy` places MATLAB into its default Cartesian axes mode. The coordinate system origin is at the lower-left corner. The *x*-axis is horizontal and is numbered from left to right. The *y*-axis is vertical and is numbered from bottom to top.

## Specifying Aspect Ratio

The `axis` command enables you to adjust the aspect ratio of graphs. Normally MATLAB stretches the axes to fill the window. In many cases, it is more useful to specify the aspect ratio of the axes based on a particular characteristic such as the relative length or scaling of each axis. The `axis` command provides a number of useful options for adjusting the aspect ratio:

- `axis equal` changes the current axes scaling so that equal tick mark increments on the *x*-, *y*-, and *z*-axis are equal in length. This makes the surface displayed by `sphere` look like a sphere instead of an ellipsoid. `axis equal` overrides stretch-to-fill behavior.
- `axis square` makes each axis the same length and overrides stretch-to-fill behavior.
- `axis vis3d` freezes aspect ratio properties to enable rotation of 3-D objects and overrides stretch-to-fill. Use this option after other `axis` options to keep settings from changing while you rotate the scene.
- `axis image` makes the aspect ratio of the axes the same as the image.
- `axis auto` returns the *x*-, *y*-, and *z*-axis limits to automatic selection mode.
- `axis normal` restores the current axis box to full size and removes any restrictions on the scaling of the units. It undoes the effects of `axis square`. Used in conjunction with `axis auto`, it undoes the effects of `axis equal`.

The `axis` command works by manipulating axes graphics object properties.

## Example – axis Command Options

The following three pictures illustrate the effects of three axis options on a cylindrical surface created with the statements

```
t = 0:pi/6:4*pi;
[x,y,z] = cylinder(4+cos(t),30);
surf(x,y,z)
```

`axis normal` is the default behavior. MATLAB automatically sets the axis limits to span the data range along each axis and stretches the plot to fit the figure window.

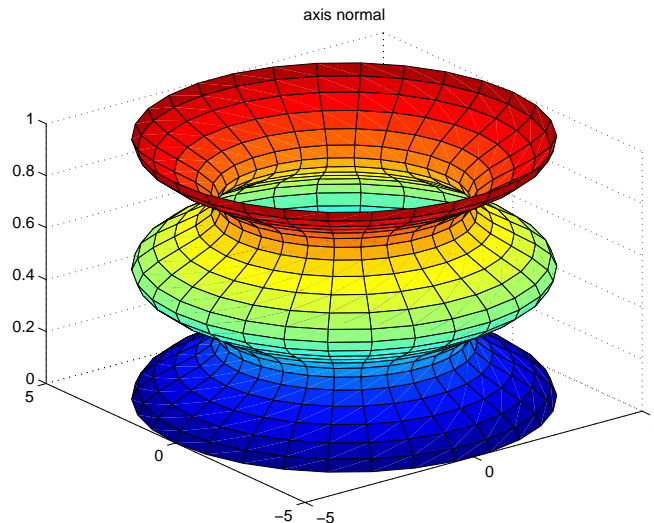

`axis square` creates an axis that is square regardless of the shape of the figure window. The cylindrical surface is no longer distorted because it is not warped to fit the window. However, the size of one data unit is not equal along all axes (the  $z$ -axis spans only one unit while the  $x$ - and  $y$ -axes span 10 units each).

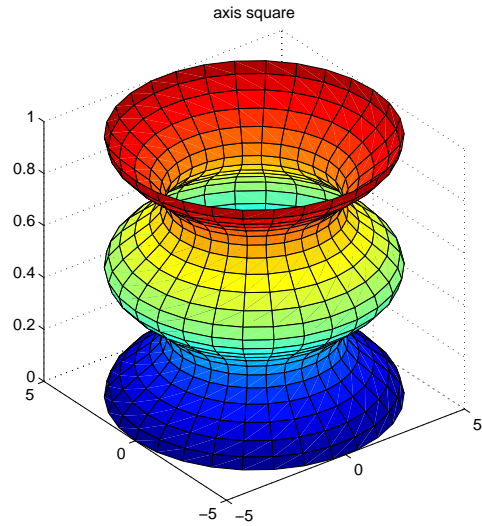

`axis equal` makes the length of one data unit equal along each axis while maintaining a nearly square plot box. It also prevents warping of the axis to fill the window's shape.

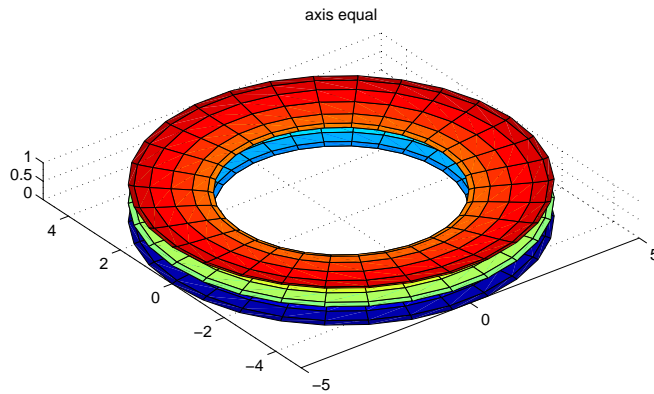



## Additional Commands for Setting Aspect Ratio

You can control the aspect ratio of your graph in three ways:

- Specifying the relative scales of the x, y, and z axes (data aspect ratio).
- Specifying the shape of the space defined by the axes (plot box aspect ratio).
- Specifying the axis limits.

The following commands enable you to set these values.

Command	Purpose
<code>daspect</code>	Set or query the data aspect ratio
<code>pbaspect</code>	Set or query the plot box aspect ratio
<code>xlim</code>	Set or query x-axis limits
<code>ylim</code>	Set or query y-axis limits
<code>zlim</code>	Set or query z-axis limits

See the “Axes Aspect Ratio Properties” section in this chapter for a list of the axes properties that control aspect ratio.

## Axes Aspect Ratio Properties

The `axis` command works by setting various axes object properties. You can set these properties directly to achieve precisely the effect you want.

Property	What It Does
<code>DataAspectRatio</code>	Sets the relative scaling of the individual axis data values. Set <code>DataAspectRatio</code> to <code>[1 1 1]</code> to display real-world objects in correct proportions. Specifying a value for <code>DataAspectRatio</code> overrides stretch-to-fill behavior.
<code>DataAspectRatioMode</code>	In auto, MATLAB selects axis scales that provide the highest resolution in the space available.
<code>PlotBoxAspectRatio</code>	Sets the proportions of the axes plot box (Set <code>box</code> to on to see the box). Specifying a value for <code>PlotBoxAspectRatio</code> overrides stretch-to-fill behavior.
<code>PlotBoxAspectRatioMode</code>	In auto, MATLAB sets the <code>PlotBoxAspectRatio</code> to <code>[1 1 1]</code> unless you explicitly set the <code>DataAspectRatio</code> and/or the axis limits.
<code>Position</code>	Defines the location and size of the axes with a four-element vector: <code>[left offset, bottom offset, width, height]</code> .
<code>XLim, YLim, ZLim</code>	Sets the minimum and maximum limits of the respective axes.
<code>XLimMode, YLimMode, ZLimMode</code>	In auto, MATLAB selects the axis limits.

By default, MATLAB automatically determines values for all of these properties (i.e., all the modes are auto) and then applies stretch-to-fill. You can override any property's automatic operation by specifying a value for the property or setting its mode to manual. The value you select for a particular property depends primarily on what type of data you want to display.

Much of the data visualized with MATLAB is either:

- Numerical data displayed as line or mesh plots
- Representations of real-world objects (e.g., a dump truck or a section of the earth's topography)

In the first case, it is generally desirable to select axis limits that provide good resolution in each axis direction and to fill the available space. Real-world objects, on the other hand, need to be represented accurately in proportion, regardless of the angle of view.

## Default Aspect Ratio Selection

There are two key elements to MATLAB's default behavior – normalizing the axes size to the window size and stretch-to-fill.

The axes `Position` property specifies the location and dimensions of the axes. The third and fourth elements of the `Position` vector (width and height) define a rectangle in which MATLAB draws the axes (indicated by the dotted line in the following pictures). MATLAB stretches the axes to fill this rectangle.

The default value for the axes `Units` property is normalized to the parent figure dimensions. This means the shape of the figure window determines the shape of the position rectangle. As you change the size of the window, MATLAB reshapes the position rectangle to fit it.

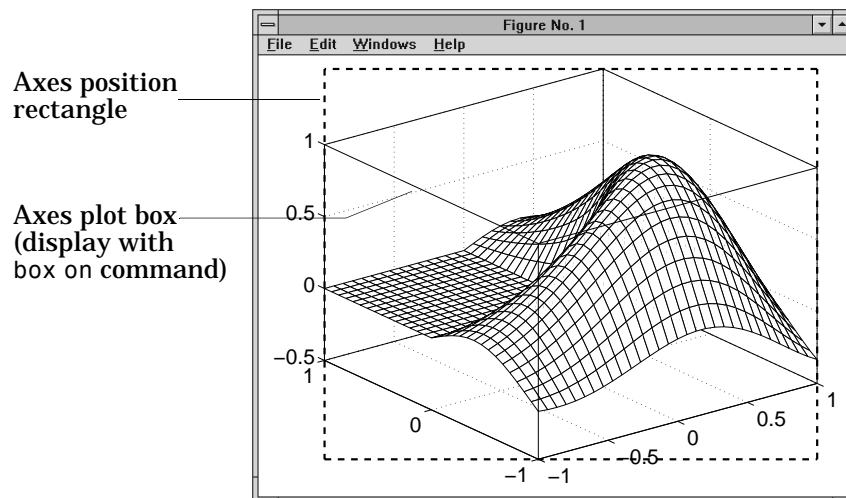

The view is the 2-D projection of the plot box onto the screen.

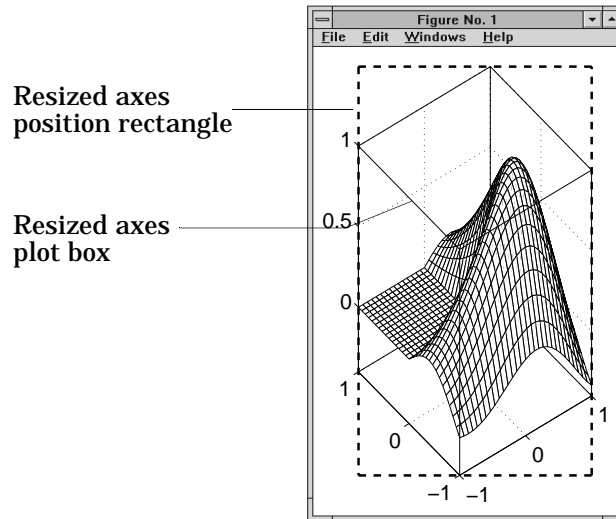

As you can see, reshaping the axes to fit into the figure window can change the aspect ratio of the graph. MATLAB applies stretch-to-fill so the axes fill the position rectangle and in the process may distort the shape. This is generally desirable for graphs of numeric data, but not for displaying objects realistically.

### Example – MATLAB Defaults

MATLAB surface plots are well suited for visualizing mathematical functions of two variables. For example, to display a mesh plot of the function,  $z = xe^{(-x^2 - y^2)}$  evaluated over the range  $-2 \leq x \leq 2$ ,  $-4 \leq y \leq 4$ , use the statements

```
[X,Y] = meshgrid([-2:.15:2],[-4:.3:4]);
Z = X.*exp(-X.^2 - Y.^2);
mesh(X,Y,Z)
```

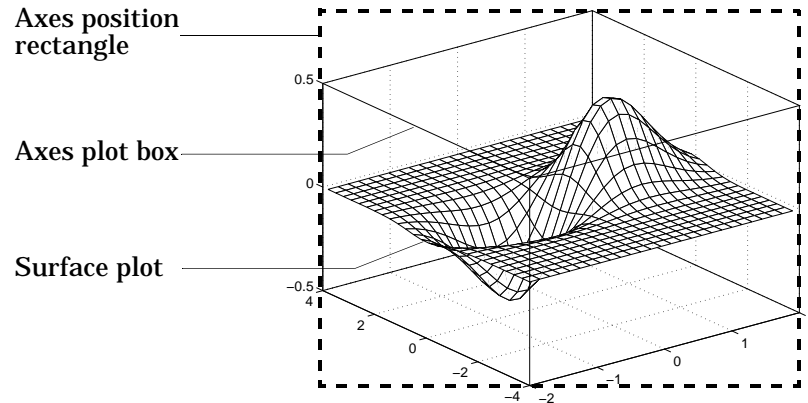

MATLAB's default property values are designed to:

- Select axis limits to span the range of the data (`XLimMode`, `YLimMode`, and `ZLimMode` are set to `auto`).
- Provide the highest resolution in the available space by setting the scale of each axis independently (`DataAspectRatioMode` and the `PlotBoxAspectRatioMode` are set to `auto`).
- Draw axes that fit the position rectangle by adjusting the `CameraViewAngle` and then stretch-to-fill the axes if necessary.

## Overriding Stretch-to-Fill

To maintain a particular shape, you can specify the size of the axes in absolute units such as inches, which are independent of the figure window size. However, this is not a good approach if you are writing an M-file that you want to work with a figure window of any size. A better approach is to specify the aspect ratio of the axes and override automatic stretch-to-fill.

In cases where you want a specific aspect ratio, you can override stretching by specifying a value for these axes properties:

- `DataAspectRatio` or `DataAspectRatioMode`
- `PlotBoxAspectRatio` or `PlotBoxAspectRatioMode`
- `CameraViewAngle` or `CameraViewAngleMode`

The first two sets of properties affect the aspect ratio directly. Setting either of the mode properties to `manual` simply disables stretch-to-fill while maintaining all current property values. In this case, MATLAB enlarges the axes until one dimension of the position rectangle constrains it.

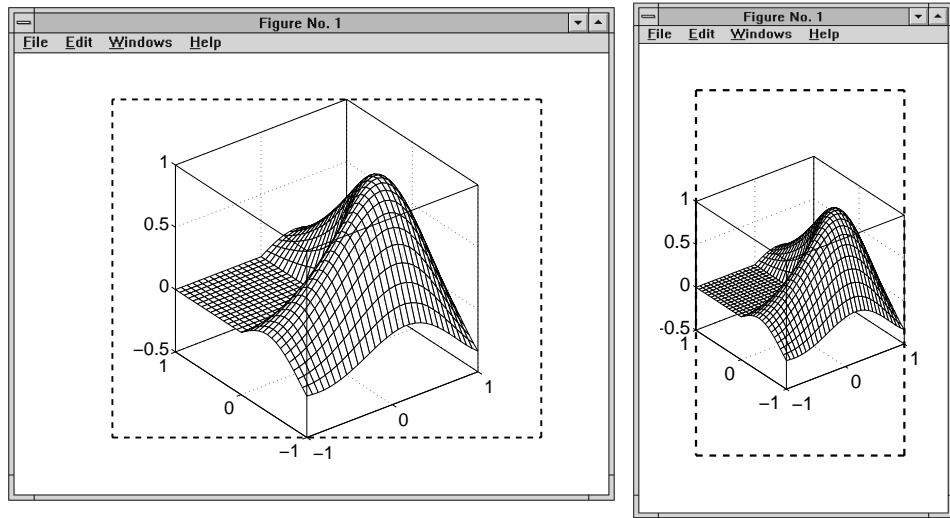

Setting the `CameraViewAngle` property disables stretch-to-fill, and also prevents MATLAB from readjusting the size of the axes if you change the view.

## Effects of Setting Aspect Ratio Properties

It is important to understand how properties interact with each other in order to obtain the results you want. The `DataAspectRatio`, `PlotBoxAspectRatio`, and the  $x$ -,  $y$ -, and  $z$ -axis limits (`XLim`, `YLim`, and `ZLim` properties) all place constraints on the shape of the axes.

### Data Aspect Ratio

The `DataAspectRatio` property controls the ratio of the axis scales. For a mesh plot of the function,  $z = xe^{(-x^2 - y^2)}$  evaluated over the range  $-2 \leq x \leq 2$ ,  $-4 \leq y \leq 4$

```
[X,Y] = meshgrid([-2:.15:2],[-4:.3:4]);
Z = X.*exp(-X.^2 - Y.^2);
```

```
mesh(X,Y,Z)
```

the values are

```
get(gca, 'DataAspectRatio')  
ans =  
    4  8  1
```

This means that four units in length along the  $x$ -axis cover the same data values as eight units in length along the  $y$ -axis and one unit in length along the  $z$ -axis. The axes fill the plot box, which has an aspect ratio of  $[1\ 1\ 1]$  by default.

If you want to view the mesh plot so that the relative magnitudes along each axis are equal with respect to each other, you can set the `DataAspectRatio` to  $[1\ 1\ 1]$ .

```
set(gca, 'DataAspectRatio', [1 1 1])
```

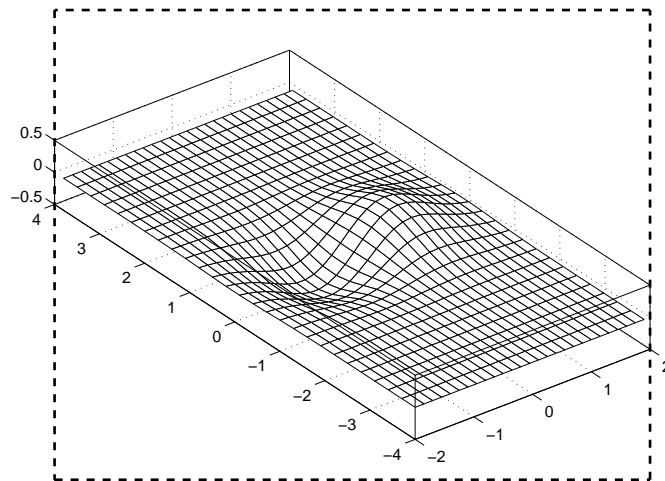

Setting the value of the `DataAspectRatio` property also sets the `DataAspectRatioMode` to `manual` and overrides `stretch-to-fill` so the specified aspect ratio is achieved.

### Plot Box Aspect Ratio

Looking at the value of the `PlotBoxAspectRatio` for the graph in the previous section shows that it has now taken on the former value of the `DataAspectRatio`.

```
get(gca, 'PlotBoxAspectRatio')
ans =
    4 8 1
```

MATLAB has rescaled the plot box to accommodate the graph using the specified `DataAspectRatio`.

The `PlotBoxAspectRatio` property controls the shape of the axes plot box. MATLAB sets this property to `[1 1 1]` by default and adjusts the `DataAspectRatio` property so that graphs fill the plot box if stretching is on, or until reaching a constraint if stretch-to-fill has been overridden.

When you set the value of the `DataAspectRatio` and thereby prevent it from changing, MATLAB varies the `PlotBoxAspectRatio` instead. If you specify both the `DataAspectRatio` and the `PlotBoxAspectRatio`, MATLAB is forced to change the axis limits to obey the two constraints you have already defined.

Continuing with the mesh example, if you set both properties,

```
set(gca, 'DataAspectRatio', [1 1 1], ...
        'PlotBoxAspectRatio', [1 1 1])
```

MATLAB changes the axis limits to satisfy the two constraints placed on the axes.



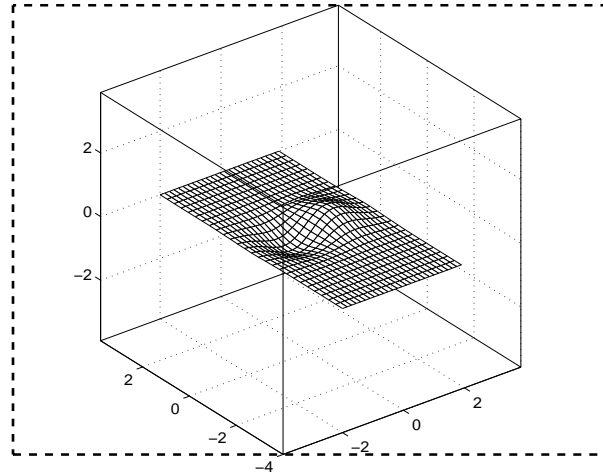

### Adjusting Axis Limits

MATLAB enables you to set the axis limits to whichever values you want. However, specifying a value for `DataAspectRatio`, `PlotBoxAspectRatio`, and the axis limits, overconstrains the axes definition. For example, it is not possible for MATLAB to draw the axes if you set these values.

```
set(gca, 'DataAspectRatio', [1 1 1], ...
        'PlotBoxAspectRatio', [1 1 1], ...
        'XLim', [-4 4], ...
        'YLim', [-4 4], ...
        'ZLim', [-1 1])
```

In this case, MATLAB ignores the setting of the `PlotBoxAspectRatio` and automatically determines its value. These particular values cause the `PlotBoxAspectRatio` to return to its calculated value.

```
get(gca, 'PlotBoxAspectRatio')
ans =
    4 8 1
```

MATLAB can now draw the axes using the specified `DataAspectRatio` and axis limits.

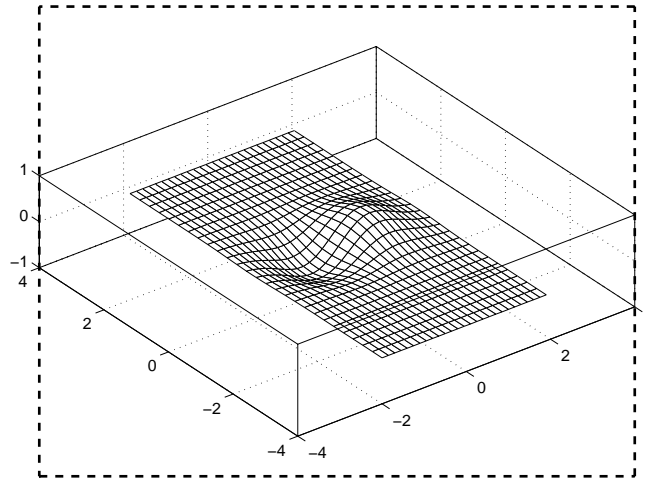

### Example – Displaying Real Objects

If you want to display an object so that it looks realistic, you need to change MATLAB's defaults. For example, this data defines a wedge-shaped patch object.

```
vertex_list =           vertex_connection =
    0     0     0         1     2     3     4
    0     1     0         2     6     7     3
    1     1     0         4     3     7     8
    1     0     0         1     5     8     4
    0     0     1         1     2     6     5
    0     1     1         5     6     7     8
    1     1     4
    1     0     4
```

```
patch('Vertices',vertex_list,'Faces',vertex_connection,...
      'FaceColor','w','EdgeColor','k')
view(3)
```

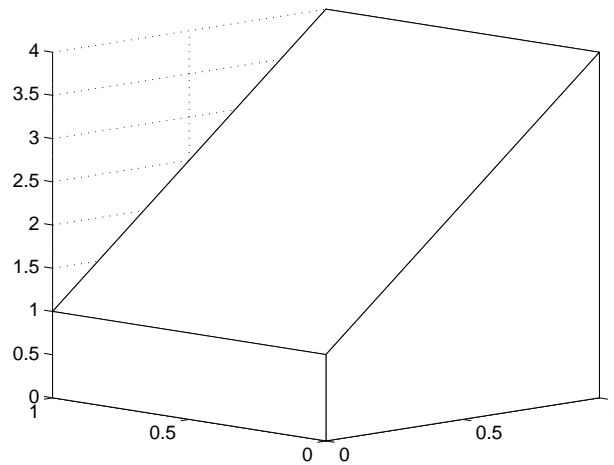

However, this axes distorts the actual shape of the solid object defined by the data. To display it in correct proportions, set the `DataAspectRatio`.

```
set(gca, 'DataAspectRatio', [1 1 1])
```

The units are now equal in the  $x$ -,  $y$ -, and  $z$ -directions and the axes is not being stretched to fill the position rectangle, revealing the true shape of the object.

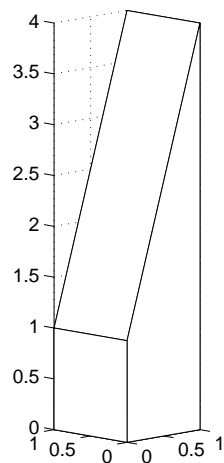



# Lighting as a Visualization Tool

---

<b>Lighting</b> . . . . .	.12-2
<b>Lighting Commands</b> . . . . .	.12-3
<b>Light Objects</b> . . . . .	.12-4
<b>Adding Lights to a Scene</b> . . . . .	.12-5
<b>Properties That Affect Lighting</b> . . . . .	.12-8
<b>Selecting a Lighting Method</b> . . . . .	.12-10
<b>Reflectance Characteristics of Graphics Objects</b> . . . . .	.12-12

## Lighting

Lighting is a technique for adding realism to a graphical scene. It does this by simulating the highlights and dark areas that occur on objects under natural lighting (e.g., the directional light that comes from the sun). To create lighting effects, MATLAB defines a graphics object called a light.

### Lighting Examples

These examples illustrate the use of lighting in a visualization context.

- Tracing a stream line through a volume – sets properties of surfaces, patches, and lights. See "Example – "Creating a Fly-Through" in the "Defining the View Chapter".
- Using slice planes and cone plots – sets lighting characteristics of objects in a scene independently to achieve a desired result. See the `coneplot` function.
- Lighting multiple slice planes independently to visualize fluid flow. See the "Example - Slicing Fluid Flow Data" section in the "Volume Visualization Techniques" chapter.
- Combining single-color lit surfaces with interpolated coloring. See the "Example - Visualizing MRI Data" section in the "Volume Visualization Techniques" chapter.
- Employing lighting to reveal surface shape. The fluid flow isosurface example and the surface plot of the `sinc` function examples illustrate this technique. See the "Example - Isosurfaces in Fluid Flow Data" section in the "Volume Visualization Techniques" chapter and the "Visualizing Functions of Two Variables" section in the "Creating 3-D Graphs" chapter.

## Lighting Commands

MATLAB provides commands that enable you to position light sources and adjust the characteristics of lit objects. These commands include the following.

Command	Purpose
<code>camlight</code>	Create or move a light with respect to the camera position
<code>lightangle</code>	Create or position a light in spherical coordinates
<code>light</code>	Create a light object
<code>lighting</code>	Select a lighting method
<code>material</code>	Set the reflectance properties of lit objects

You may find it useful to set light or lit-object properties directly to achieve specific results. In addition to the material in this topic area, you can explore the following lighting examples as an introduction to lighting for visualization.

## Light Objects

You create a light object using the `light` function. Three important light object properties are:

- `Color` – the color of the light cast by the light object
- `Style` – either infinitely far away (the default) or local
- `Position` – the direction (for infinite light sources) or the location (for local light sources)

The `Color` property determines the color of the directional light from the light source. The color of an object in a scene is determined by the color of the object and the light source.

The `Style` property determines whether the light source is a point source (`Style` set to `local`), which radiates from the specified position in all directions, or a light source placed at infinity (`Style` set to `infinite`), which shines from the direction of the specified position with parallel rays.

The `Position` property specifies the location of the light source in axes data units. In the case of an light source at infinity, `Position` specifies the direction to the light source.

Lights affect surface and patch objects that are in the same axes as the light. These objects have a number of properties that alter the way they look when illuminated by lights.



## Adding Lights to a Scene

This example displays the membrane surface and illuminates it with a light source emanating from the direction defined by the position vector  $[0 \ -2 \ 1]$ . This vector defines a direction from the axes origin passing through the point with the coordinates 0, -2, 1. The light shines from this direction towards the axes origin.

```
membrane
light('Position',[0 -2 1])
```

Creating a light activates a number of lighting-related properties controlling characteristics, such as the ambient light and reflectance properties of objects. It also switches to Z-buffer renderer if not already in that mode.

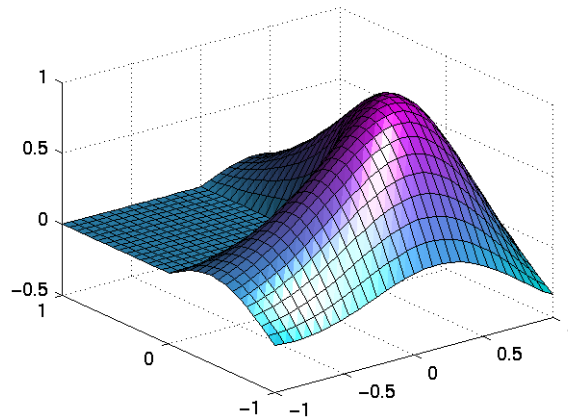

### Illuminating Mathematical Functions

Lighting can enhance surface graphs of mathematical functions. For example, use the `ezsurf` command to evaluate the expression

$\sin(\sqrt{x^2 + y^2}) / \sqrt{x^2 + y^2}$  over the region  $-6\pi$  to  $6\pi$ .

```
ezsurf('sin(sqrt(x^2+y^2))/sqrt(x^2+y^2)',[-6*pi,6*pi])
```

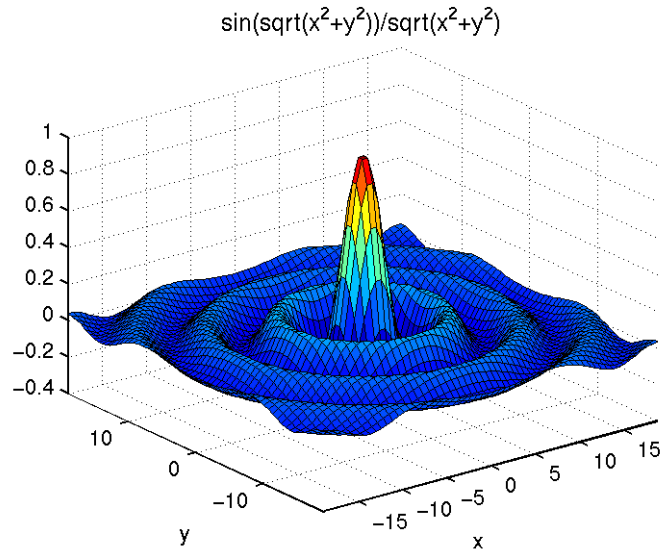

Now add lighting using the `lightangle` command, which accepts the light position in terms of azimuth and elevation.

```
view(0,75)
shading interp
lightangle(-45,30)
set(gcf,'Renderer','zbuffer')
set(findobj(gca,'type','surface'),...
    'FaceLighting','phong',...
    'AmbientStrength',.3,'DiffuseStrength',.8,...
    'SpecularStrength',.9,'SpecularExponent',25,...
    'BackFaceLighting','unlit')
```

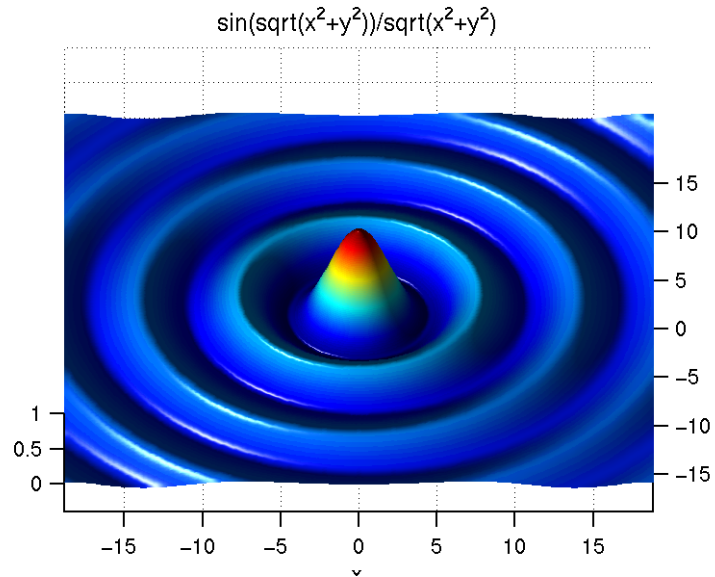

After obtaining surface object's handle using `findobj`, you can set properties that affect how the light reflects from the surface. See the "Properties That Affect Lighting" section of this chapter for more detailed descriptions of these properties.

## Properties That Affect Lighting

You cannot see light objects themselves, but you can see their effects on any patch and surface objects present in the axes containing the light. A number of functions create these objects, including `surf`, `mesh`, `pcolor`, `fill`, and `fill3` as well as the `surface` and `patch` functions.

You control lighting effects by setting various axes, `light`, `patch`, and `surface` object properties. All properties have default values that generally produce desirable results. However, you can achieve the specific effect you want by adjusting the values of these properties.

Property	Effect
<code>AmbientLightColor</code>	An axes property that specifies the color of the background light in the scene, which has no direction and affects all objects uniformly. Ambient light effects occur only when there is a visible light object in the axes.
<code>AmbientStrength</code>	A patch and surface property that determines the intensity of the ambient component of the light reflected from the object.
<code>DiffuseStrength</code>	A patch and surface property that determines the intensity of the diffuse component of the light reflected from the object.
<code>SpecularStrength</code>	A patch and surface property that determines the intensity of the specular component of the light reflected from the object.
<code>SpecularExponent</code>	A patch and surface property that determines the size of the specular highlight.
<code>SpecularColorReflectance</code>	A patch and surface property that determines the degree to which the specularly reflected light is colored by the object color or the light source color.
<code>FaceLighting</code>	A patch and surface property that determines the method used to calculate the effect of the light on the faces of the object. Choices are either no lighting, or flat, Gouraud, or Phong lighting algorithms.

Property	Effect
EdgeLighting	A patch and surface property that determines the method used to calculate the effect of the light on the edges of the object. Choices are either no lighting, or flat, Gouraud, or Phong lighting algorithms.
BackFaceLighting	A patch and surface property that determines how faces are lit when their vertex normals point away from the camera. This property is useful for discriminating between the internal and external surfaces of an object.
FaceColor	A patch and surface property that specifies the color of the object faces.
EdgeColor	A patch and surface property that specifies the color of the object edges.
VertexNormals	A patch and surface property that contains normal vectors for each vertex of the object. MATLAB uses vertex normal vectors to perform lighting calculations. While MATLAB automatically generates this data, you can also specify your own vertex normals.
NormalMode	A patch and surface property that determines whether MATLAB recalculates vertex normals if you change object data (auto) or uses the current values of the VertexNormals property (manual). If you specify values for VertexNormals, MATLAB sets this property to manual.

See a description of all axes, surface, and patch object properties.

## Selecting a Lighting Method

When you add lights to an axes, MATLAB determines the effects these lights have on the patch and surface objects that are displayed in that axes. There are different methods used to calculate the face and edge coloring of lit objects, and the one you select depends on the results you want to obtain.

### Face and Edge Lighting Methods

MATLAB supports three different algorithms for lighting calculations, selected by setting the `FaceLighting` and `EdgeLighting` properties of each patch and surface object in the scene. Each algorithm produces somewhat different results:

- Flat lighting produces uniform color across each of the faces of the object. Select this method to view faceted objects.
- Gouraud lighting calculates the colors at the vertices and then interpolates colors across the faces. Select this method to view curved surfaces.
- Phong lighting interpolates the vertex normals across each face and calculates the reflectance at each pixel. Select this choice to view curved surfaces. Phong lighting generally produces better results than Gouraud lighting, but takes longer to render.

This illustration shows how a red sphere looks using each of the lighting methods with one white light source.

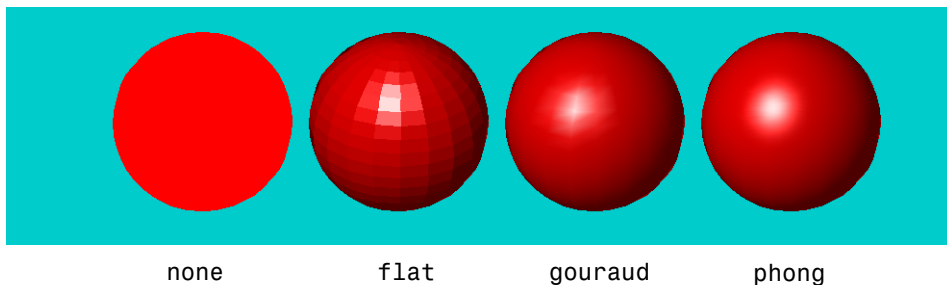

**The lighting command (as opposed to the light function) provides a convenient way to set the lighting method.**

### Reflectance Characteristics of Graphics Objects

You can modify the reflectance characteristics of patch and surface objects and thereby change the way they look when lights are applied to the scene. The characteristics discussed in this section include:

- Specular and diffuse reflection
- Ambient light
- Specular exponent
- Specular color reflectance
- Backface lighting

It is likely you will adjust these characteristics in combination to produce particular results.

Also see the `material` command for a convenient way to produce certain lighting effects.

#### Specular and Diffuse Reflection

You can control the amount of specular and diffuse reflection from the surface of an object by setting the `SpecularStrength` and `DiffuseStrength` properties. This picture illustrates various settings.



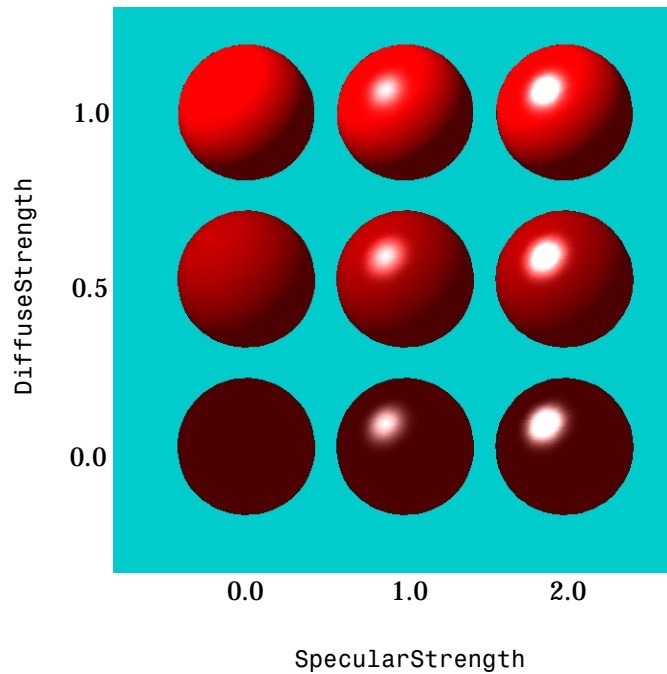

## Ambient Light

Ambient light is a directionless light that shines uniformly on all objects in the scene. Ambient light is visible only when there are light objects in the axes. There are two properties that control ambient light – AmbientLightColor is an axes property that sets the color, and AmbientStrength is a property of patch and surface objects that determines the intensity of the ambient light on the particular object.

This illustration shows three different ambient light colors at various intensities. The sphere is red and there is a white light object present.

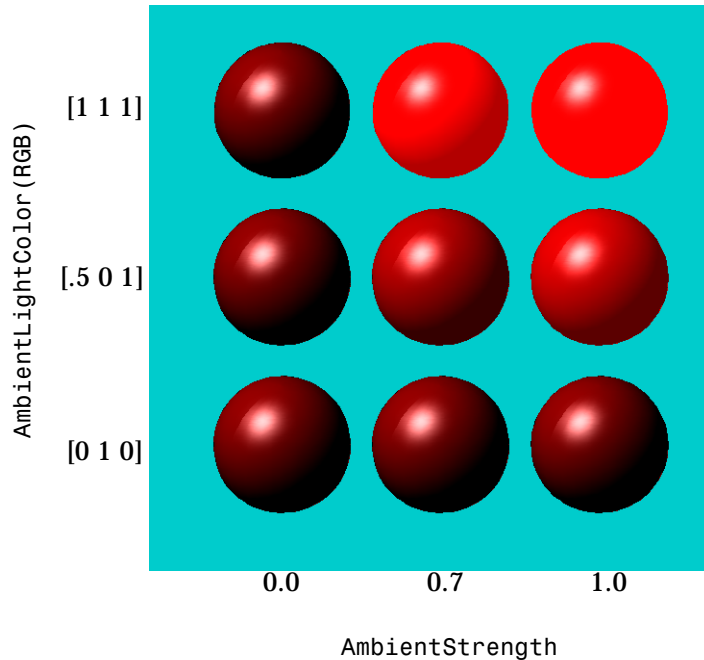

The green  $[0\ 1\ 0]$  ambient light does not affect the scene because there is no red component in green light. However, the color defined by the RGB values  $[\.5\ 0\ 1]$  does have a red component, so it contributes to the light on the sphere (but less than the white  $[1\ 1\ 1]$  ambient light).

## Specular Exponent

The size of the specular highlight spot depends on the value of the patch and surface object's `SpecularExponent` property. Typical values for this property range from 1 to 500, with normal objects having values in the range 5 to 20.

This illustration shows a red sphere illuminated by a white light with three different values for the `SpecularExponent` property.

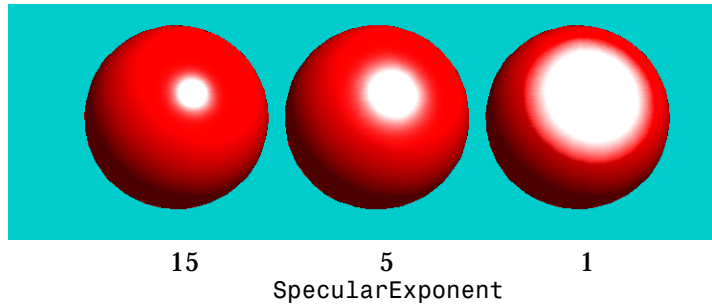

### Specular Color Reflectance

The color of the specularly reflected light can range from a combination of the color of the object and the color of the light source to the color of the light source only. The patch and surface `SpecularColorReflectance` property controls this color. This illustration shows a red sphere illuminated by a white light. The values of the `SpecularColorReflectance` property range from 0 (object and light color) to 1 (light color).

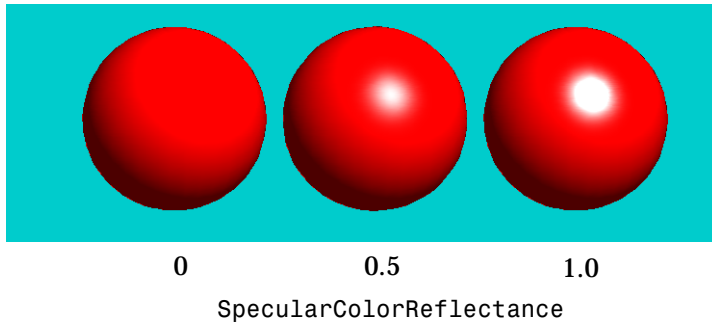

### Back Face Lighting

Back face lighting is useful for showing the difference between internal and external faces. These pictures of cut-away cylindrical surfaces illustrate the effects of back face lighting.

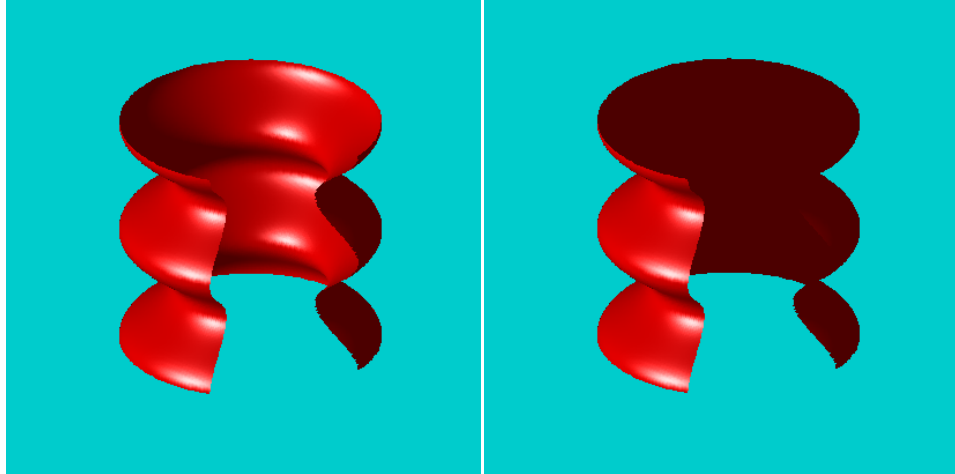

BackFaceLighting = reverselit

BackFaceLighting = unlit

The default value for `BackFaceLighting` is `reverselit`. This setting reverses the direction of the vertex normals that face away from the camera, causing the interior surface to reflect light towards the camera. Setting `BackFaceLighting` to `unlit` disables lighting on faces with normals that point away from the camera.

You can also use `BackFaceLighting` to remove edge effects for closed objects. These effects occur when `BackFaceLighting` is set to `reverselit` and pixels along the edge of a closed object are lit as if their vertex normals faced the camera. This produces an improperly lit pixel because the pixel is visible but is really facing away from the camera.

To illustrate this effect, the next picture shows a blowup of the edge of a lit sphere. Setting `BackFaceLighting` to `lit` prevents the improper lighting of pixels.

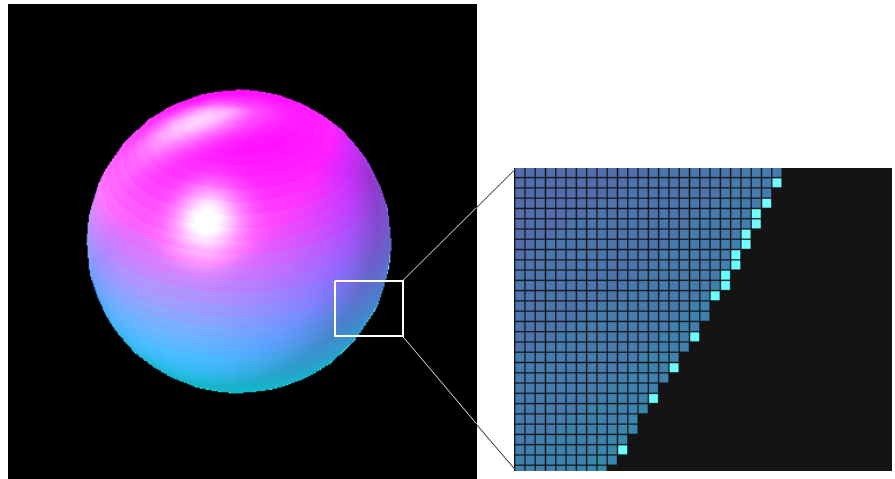

BackFaceLighting = reverselit

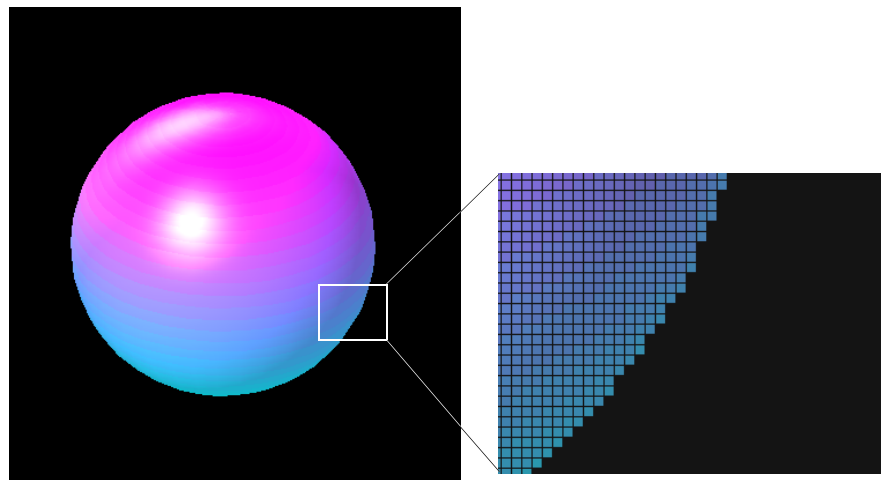

BackFaceLighting = lit

## Positioning Lights in Data Space

This example creates a sphere and a cube to illustrate the effects of various properties on lighting. The variables `vert` and `fac` define the cube using the `patch` function.

```

vert =
    1    1    1
    1    2    1
    2    2    1
    2    1    1
    1    1    2
    1    2    2
    2    2    2
    2    1    2

fac =
    1    2    3    4
    2    6    7    3
    4    3    7    8
    1    5    8    4
    1    2    6    5
    5    6    7    8

sphere(36);
h = findobj('Type','surface');
set(h,'FaceLighting','phong',...
    'FaceColor','interp',...
    'EdgeColor',[.4 .4 .4],...
    'BackFaceLighting','lit')
hold on
patch('faces',fac,'vertices',vert,'FaceColor','y');
light('Position',[1 3 2]);
light('Position',[-3 -1 3]);
material shiny
axis vis3d off
hold off

```

All faces of the cube have `FaceColor` set to yellow. The `sphere` function creates a spherical surface and the handle of this surface is obtained using `findobj` to search for the object whose `Type` property is `surface`. The light functions define two, white (the default color) light objects located at infinity in the direction specified by the `Position` vectors. These vectors are defined in axes coordinates  $[x, y, z]$ .

The `patch` uses `flat FaceLighting` (the default) to enhance the visibility of each side. The surface uses `phong FaceLighting` because it produces the smoothest interpolation of lighting effects. The material `shiny`

command affects the reflectance properties of both the cube and sphere (although its effects are noticeable only on the sphere because of the cube's flat shading).

Since the sphere is closed, the `BackFaceLighting` property is changed from its default setting, which reverses the direction of vertex normals that face away from the camera, to normal lighting, which removes undesirable edge effects.

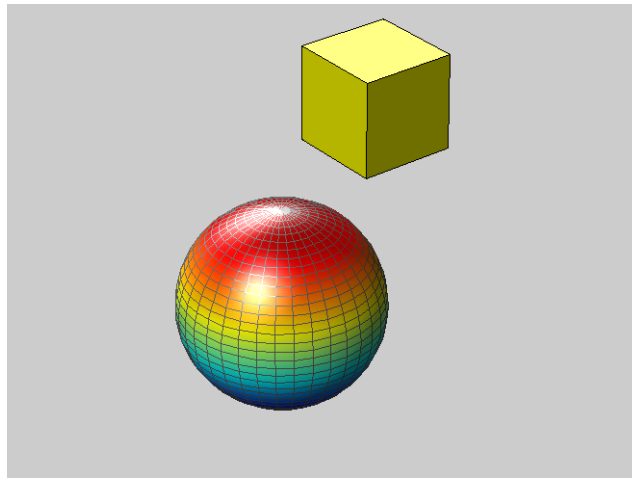

Examining the code in the `lighting` and `material M-files` can help you understand how various properties affect lighting.





# Transparency

---

<b>Overview</b> . . . . .	13-2
<b>Making Objects Transparent</b> . . . . .	13-3
Specifying Transparency . . . . .	13-4
<b>Specifying a Single Transparency Value for an Object</b> .	13-6
Example – Transparent Isosurface . . . . .	13-6
<b>Mapping Data to Transparency</b> . . . . .	13-8
Size of the Alpha Data Array . . . . .	13-9
Mapping Alpha Data to the Alphamap . . . . .	13-9
Example: Mapping Data to Color or Transparency . . . . .	13-9
<b>Selecting an Alphamap</b> . . . . .	13-11
Example: Modifying the Alphamap . . . . .	13-13

## Transparency Topics

Making graphics objects semi-transparent is a useful technique in 3-D visualization to make it possible to see an object, while at the same time, see what information the object would obscure if it was completely opaque. You can also use transparency as another dimension for displaying data, much the way color is used in MATLAB.

These sections describe how to use the various transparency properties of objects to enhance certain types of visualizations.

- **Making Objects Transparent** – provides an overview of the object properties that specify transparency.
- **Specifying a Single Transparency Value** – describes how to specify a transparency value that applies to all the faces of a graphics object.
- **Mapping Data to Transparency** – shows how to use transparency as another dimension for visualizing data.
- **Selecting an Alphamap** – describes characteristics of various alphamaps and illustrates the effects they produce.

## Making Objects Transparent

The transparency of a graphics object determines the degree to which you can see through the object. You can specify a continuous range of transparency varying from completely transparent (i.e., invisible) to completely opaque (i.e., no transparency).

Objects that support transparency are:

- Image
- Patch
- Surface

The following picture illustrates the effect of transparency. The green isosurface (patch object) reveals the coneplot that lies in the interior.

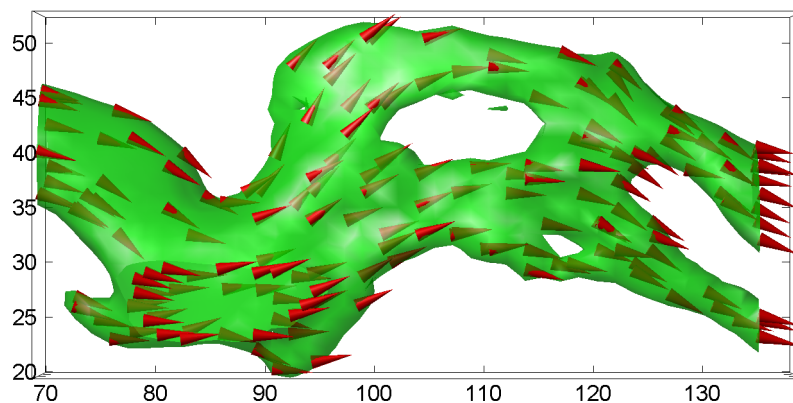

---

**Note** You must have OpenGL available on your system to use transparency. MATLAB automatically uses OpenGL if it is available. See the figure `RendererMode` property for more information.

---

## Specifying Transparency

Transparency values, which range from [0 1], are referred to as *alpha* values. An alpha value of 0 means completely transparent (i.e., invisible); an alpha value of 1 means completely opaque (i.e., no transparency).

MATLAB treats transparency in a way that is analogous to how it treats color for the respective objects:

- Patches and surfaces can define a single face and edge alpha value or use flat or interpolated transparency based on values in the figure's alphamap.
- Images, patches, and surfaces can define alpha data that is used as indices into the alphamap or directly as alpha values.
- Axes define alpha limits that control the mapping of object data to alpha values.
- Figures contain alphamaps, which are m-by-1 arrays of alpha values.

See the following sections for more information on color:

- “Specifying Patch Coloring” in the “Creating 3-D Models with Patches” chapter.
- “Coloring Mesh and Surface Plots” in the “Creating 3-D Graphs” chapter.

### Transparency Properties

The following table summarizes the object properties that control transparency.

Properties	Purpose
AlphaData	The transparency data for image and surface objects
AlphaDataMapping	The transparency data mapping method
FaceAlpha	Transparency of the faces (patch and surface only)
EdgeAlpha	Transparency of the edges (patch and surface only)

<b>Properties</b>	<b>Purpose</b>
FaceVertexAlphaData	Patch only alpha data property
ALim	Alpha axis limits
ALimMode	Alpha axis limits mode
Alphamap	Figure alphamap

### Transparency Functions

There are three functions that simplify the process of setting alpha properties.

<b>Function</b>	<b>Purpose</b>
alpha	Set or query transparency properties for objects in current axes
alphamap	Specify the figure alphamap
alim	Set or query the axes alpha limits

## Specifying a Single Transparency Value

Specifying a single transparency value for graphics objects is useful when you want to reveal structure that is obscured with opaque objects. For patches and surfaces, use the `FaceAlpha` and `EdgeAlpha` properties to specify the transparency of faces and edges. The following example illustrates this.

### Example – Transparent Isosurface

This example uses the `flow` function to generate data for the speed profile of a submerged jet within a infinite tank. One way to visualize this data is by creating an isosurface illustrating where the rate of flow is equal to a specified value.

```
[x y z v] = flow;  
p = patch(isosurface(x,y,z,v,-3));  
isonormals(x,y,z,v,p);  
set(p,'facecolor','red','edgecolor','none');  
daspect([1 1 1]);  
view(3); axis tight; grid on;  
camlight; lighting gouraud;
```

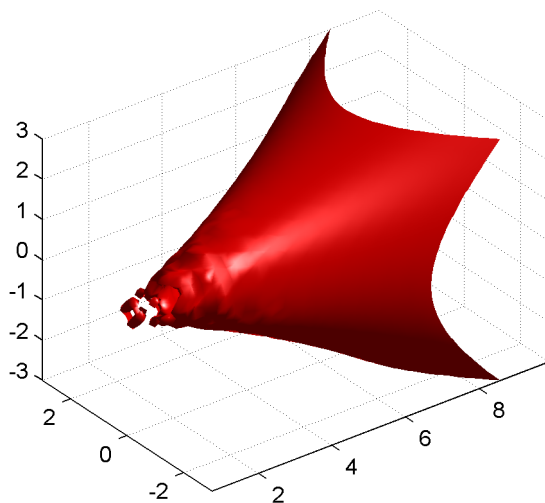

Adding transparency to the isosurface reveals that there is greater complexity in the fluid flow than is visible using the opaque surface. The statement

```
alpha(.5)
```

sets the FaceAlpha value for the isosurface face to .5.

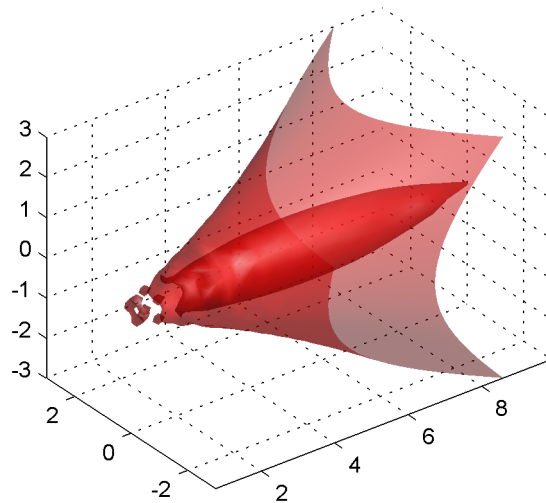

### Setting a Single Transparency Value for Images

For images, the statement

```
alpha(.5)
```

sets the AlphaData to .5. When the AlphaDataMapping property is set to none (the default), setting AlphaData on an image causes the entire image to render with the specified alpha value.

## Mapping Data to Transparency

Alpha data is analogous to color data (e.g., the `CData` property of surfaces). When you create a surface, MATLAB maps each element in the color data array to a color in the colormap. Similarly, each element in the alpha data maps to a transparency value in the alphamap.

Specify surface and image alpha data with the `AlphaData` property. For patch objects, use the `FaceVertexAlphaData` property.

You can control how MATLAB interprets alpha data with the following properties:

- `FaceAlpha` and `EdgeAlpha` – enable you to select flat or interpolated transparency rendering. If set to a single transparency value, MATLAB applies this value to all faces or edges and does not use the alpha data.
- `AlphaDataMapping` and `ALim` – determine how MATLAB maps the alpha data to the alphamap. By default, MATLAB scales the alpha data to be within the range [0 1].
- `Alphamap` – contains the actual transparency values to which the data is to be mapped.

Note that there are differences between the default values of equivalent color and alpha properties because, in contrast to color, transparency is not displayed by default. The following table highlights these differences.

Color Property	Default	Alpha Property	Default
<code>FaceColor</code>	flat	<code>FaceAlpha</code>	1 (opaque)
<code>CData</code>	equal to <code>ZData</code>	<code>AlphaData</code> and <code>FaceVertexAlphaData</code>	1 (scalar)

By default, objects have single-valued alpha data. Therefore you cannot specify flat or interp `FaceAlpha` or `EdgeAlpha` without first setting `AlphaData` to an array of the appropriate size.

The sections that follow illustrate how to use these properties to display object data as degrees of transparency.



## Size of the Alpha Data Array

In order to use nonscalar alpha data, you need to specify the alpha data as an array equal in size to the:

- CData of images and surfaces
- The number of faces (flat) or the number of vertices (interpolated) defined in the FaceVertexAlphaData property of patches

Once you have specified an alpha data array of the proper size, you can select the face and edge rendering you want to use. Flat uses one transparency value per face, while interpolated performs bilinear interpolation of the values at each vertex.

## Mapping Alpha Data to the Alphamap

You can control how MATLAB maps the alpha data to the alphamap using the AlphaDataMapping property. There are three possible mappings:

- none – Interpret the values in alpha data as transparency values (data values must be between 0 and 1, or will be clamped to 0 or 1). This is the default mapping.
- scaled – Transform the alpha data to span the portion of the alphamap indicated by the axes ALim property, linearly mapping data values to alpha values. This is the same way color data is mapped to the colormap.
- direct – Use the alpha data directly as indices into the figure alphamap.

By default, objects have scalar alpha data (AlphaData and FaceVertexAlphaData) set to the value 1.

## Example: Mapping Data to Color or Transparency

This example displays a surface plot of a functions of two variables. The color is mapped to the gradient of the z data.

```
[x,y] = meshgrid([-2:.2:2]);  
z = x.*exp(-x.^2-y.^2);  
surf(x,y,z,gradient(z)); axis tight
```

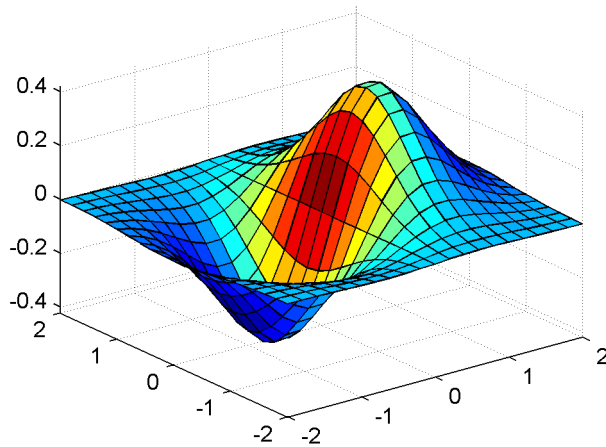

You can map transparency to the gradient of  $z$  in a similar way.

```
surf(x,y,z,'FaceAlpha','flat',...
      'AlphaDataMapping','scaled',...
      'AlphaData',gradient(z),...
      'FaceColor','blue');
axis tight
```

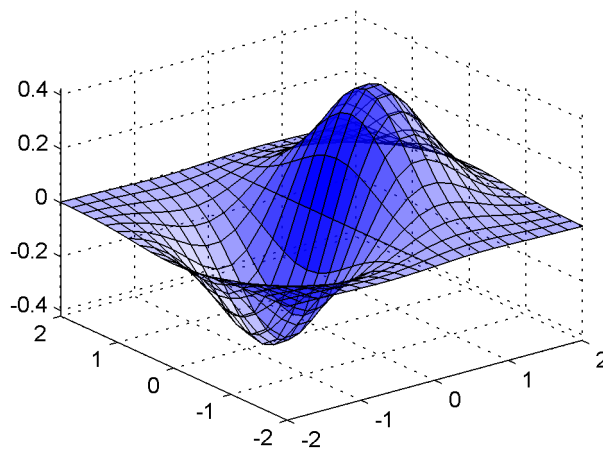

## Selecting an Alphamap

An alphamap is simply an array of values ranging from 0 to 1. The size of the array can be either m-by-1 or 1-by-m.

The default alphamap contains 64 values ranging linearly from 0 to 1, as you can see in the following plot.

```
plot(get(gcf, 'Alphamap'))
```

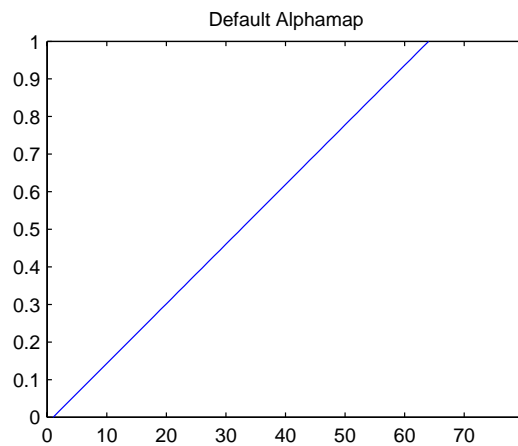

This alphamap displays the lowest alpha data values as completely transparent and the highest alpha data values as opaque.

The alphamap function creates some useful predefined alphamaps and also enables you to modify existing maps. For example,

```
plot(alphamap('vup'))
```

produces the following alphamap.

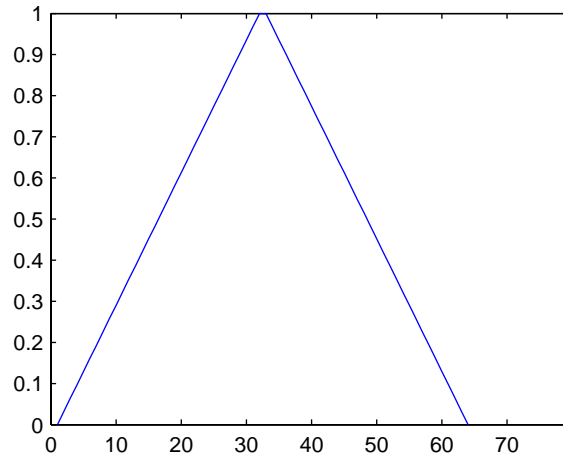

You can shift the values using the `increase` or `decrease` options. For example,

```
alphamap('increase', .4)
```

adds the value `.4` to all values in the current figure's `alphamap`. Replotting the `'vup'` `alphamap` illustrates the change. Note how the values are clamped to the range `[0 1]`.

```
plot(get(gcf, 'Alphamap'))
```

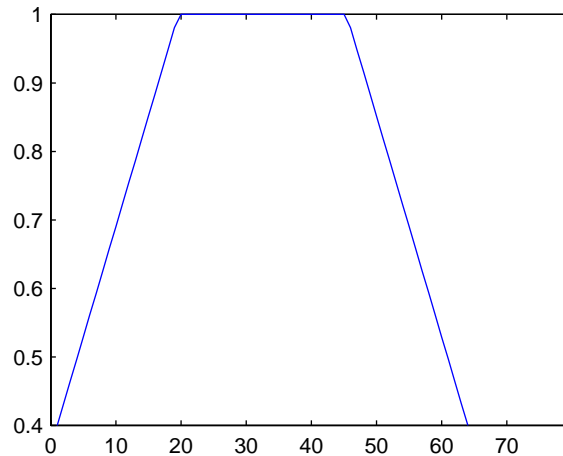

### Example: Modifying the Alphamap

This example uses slice planes to examine volume data. The slice planes use the color data for alpha data and employ a rampdown alphamap (the values range from 1 to 0):

- 1 Create the volume data by evaluating a function of three variables.

```
[x,y,z] = meshgrid(-1.25:.1:-.25,-2:.2:2,-2:.1:2);
v = x.*exp(-x.^2-y.^2-z.^2);
```

- 2 Create the slice planes, set the alpha data equal to the color data, and specify interpolated FaceAlpha.

```
h = slice(x,y,z,v,[-1 -.75 -.5],[],[0]);
alpha('color')
set(h,'EdgeColor','none','FaceColor','interp',...
    'FaceAlpha','interp')
```

- 3 Install the rampdown alphamap and increase each value in the alphamap by .1 to achieve the desired degree of transparency. Specify the hsv colormap.

```
alphamap('rampdown')
alphamap('increase',.1)
```

```
colormap(hsv)
```

This colormap causes the smallest values of the function (around zero) to display with the least transparency and the greatest values to display with the most transparency. This enables you to see through the slice planes, while at the same time preserving the data around zero.

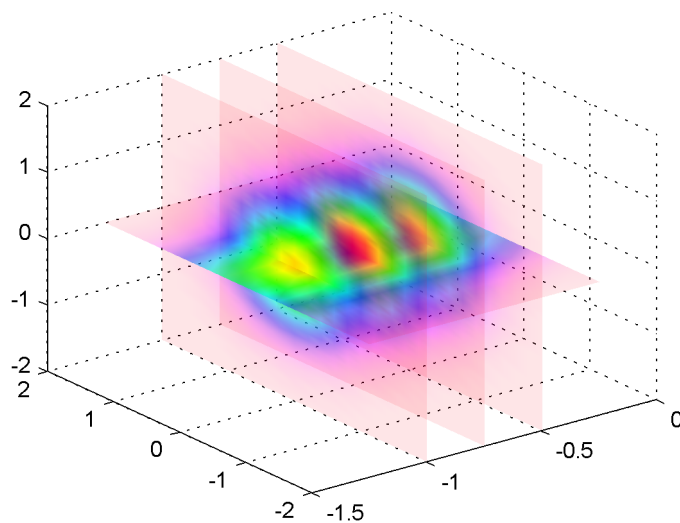

# Creating 3-D Models with Patches

---

<b>Introduction to Patch Objects</b> . . . . .	14-2
Defining Patches . . . . .	14-2
Behavior of the patch Function . . . . .	14-2
Creating a Single Polygon . . . . .	14-4
<b>Multi-Faceted Patches</b> . . . . .	14-6
Example – Defining a Cube . . . . .	14-6
<b>Specifying Patch Coloring</b> . . . . .	14-11
<b>Face and Edge Coloring</b> . . . . .	14-13
Example – Specifying Flat Edge and Face Coloring . . . . .	14-13
Coloring Edges with Shared Vertices . . . . .	14-14
<b>How MATLAB Interprets Patch Color Data</b> . . . . .	14-16
Indexed Color Data . . . . .	14-16
Truecolor Patches . . . . .	14-19
Interpolating in Indexed Color vs. Truecolor . . . . .	14-19

## Introduction to Patch Objects

A patch graphics object is composed of one or more polygons that may or may not be connected. Patches are useful for modeling real-world objects such as airplanes or automobiles, and for drawing 2- or 3-D polygons of arbitrary shape. In contrast, surface objects are rectangular grids of quadrilaterals and are better suited for displaying planar topographies such as the values of some mathematical functions, the contours of data in a rectangular plane, or parameterized surfaces such as a sphere.

A number of MATLAB functions create patch objects – `fill`, `fill3`, `isosurface`, `isocaps`, some of the contour functions, and `patch`. This section concentrates on use of the `patch` function.

### Defining Patches

You define a patch by specifying the coordinates of its vertices and some form of color data. Patches support a variety of coloring options that are useful for visualizing data superimposed on geometric shapes.

There are two ways to specify a patch:

- By specifying the coordinates of the vertices of each polygon, which MATLAB connects to form the patch
- By specifying the coordinates of each *unique* vertex and a matrix that specifies how to connect these vertices to form the faces

The second technique is preferred for multifaceted patches because it generally requires less data to define the patch; vertices shared by more than one face need be defined only once. This topic area provides examples of both techniques.

### Behavior of the patch Function

There are two forms of the `patch` function – high-level syntax and low-level syntax. The behavior of the `patch` function differs somewhat depending on which syntax you use.

#### High-Level Syntax

When you use the high-level syntax, MATLAB automatically determines how to color each face based on the color data you specify. The high-level syntax



enables you to omit the property names for the  $x$ -,  $y$ -, and  $z$ -coordinates and the color data, as long as you specify these arguments in the correct order.

```
patch(x-coordinates,y-coordinates,z-coordinates,colordata)
```

However, you must specify color data so MATLAB can determine what type of coloring to use. If you do not specify color data, MATLAB returns an error.

```
patch(sin(t),cos(t))
??? Error using ==> patch
Not enough input arguments.
```

### Low-Level Syntax

The low-level syntax accepts only property name/property value pairs as arguments and does not automatically color the faces unless you also change the value of the `FaceColor` property. For example, the statement

```
patch('XData',sin(t),'YData',cos(t)) % Low-level syntax
```

draws a patch with white face color because the factory default value for the `FaceColor` property is the color white.

```
get(0,'FactoryPatchFaceColor')
ans =
     1     1     1
```

See the list of patch properties in the MATLAB Function Reference and the `get` command for information on how to obtain the factory and user default values for properties.

### Interpreting the Color Argument

When you use the informal syntax, MATLAB interprets the third (or fourth if there are  $z$ -coordinates) argument as color data. If you intend to define a patch with  $x$ -,  $y$ -, and  $z$ -coordinates, but leave out the color, MATLAB interprets the  $z$ -coordinates as color data, and then draws a 2-D patch. For example,

```
h = patch(sin(t),cos(t),1:length(t))
```

draws a patch with all vertices at  $z = 0$ , colored by interpolating the vertex colors (since there is one color for each vertex), whereas

```
h = patch(sin(t),cos(t),1:length(t),'y')
```

draws a patch with vertices at increasing values of  $z$ , colored yellow.

The “Specifying Patch Coloring” section in this chapter provides more information on options for coloring patches.

## Creating a Single Polygon

A polygon is simply a patch with one face. To create a polygon, specify the coordinates of the vertices and color data with a statement of the form.

```
patch(x-coordinates,y-coordinates,[z-coordinates],colordata)
```

For example, these statements display a 10-sided polygon with a yellow face enclosed by a black edge. The `axis equal` command produces a correctly proportioned polygon.

```
t = 0:pi/5:2*pi;  
patch(sin(t),cos(t),'y')  
axis equal
```

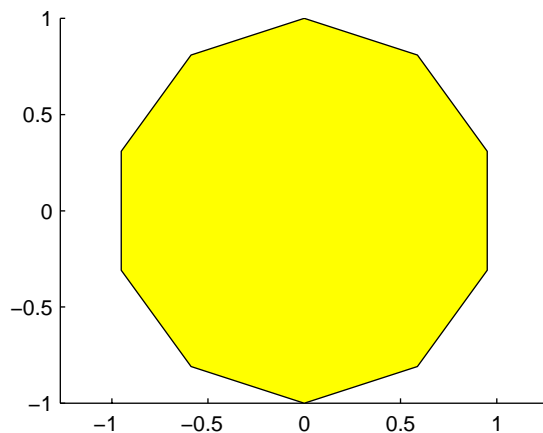

The first and last vertices need not coincide; MATLAB automatically closes each polygonal face of the patch. In fact, it is generally better to define each vertex only once, particularly if you are using interpolated face coloring.

## Interpolated Face Colors

You can control many aspects of the patch coloring. For example, instead of specifying a single color, you can provide a range of numerical values that map the color at each vertex to a color in the figure colormap.

```
a = t(1:length(t)-1); %remove redundant vertex definition
patch(sin(a),cos(a),1:length(a),'FaceColor','interp')
colormap cool;
axis equal
```

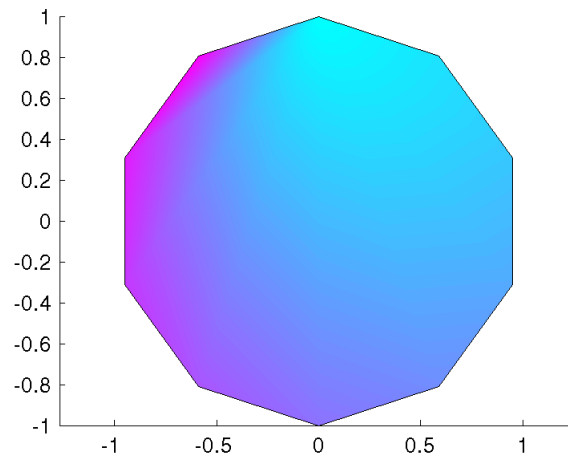

MATLAB now interpolates the colors across the face of the patch. You can color the edges of the patch the same way, by setting the edge colors to be interpolated. The command is

```
patch(sin(t),cos(t),1:length(t),'EdgeColor','interp')
```

The “Specifying Patch Coloring” section in this chapter provides more information on options for coloring patches.

## Multi-Faceted Patches

If you specify the  $x$ -,  $y$ -, and  $z$ -coordinate arguments as vectors, MATLAB draws a single polygon by connecting the points. If the arguments are matrices, MATLAB draws one polygon per column, producing a single patch with multiple faces. These faces need not be connected and can be self-intersecting.

Alternatively, you can specify the coordinates of each unique vertex and the order in which to connect them to form the faces. The examples in this section illustrate both techniques.

### Example - Defining a Cube

A cube is defined by eight vertices that form six sides. This illustration shows the coordinates of the vertices defining a cube in which the sides are one unit in length.

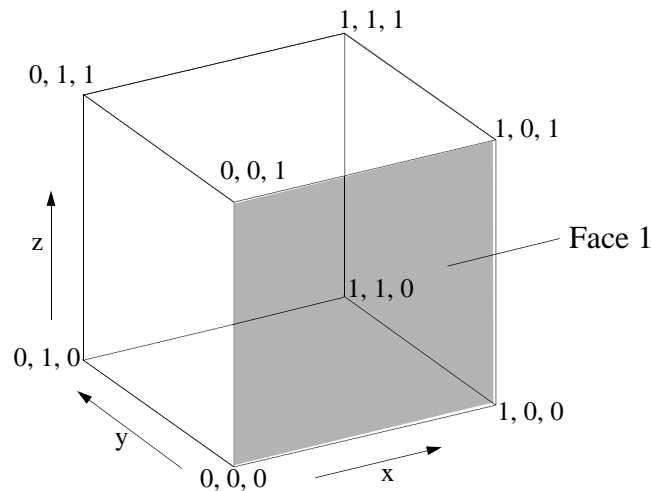

### Specifying X, Y, and Z Coordinates

Each of the six faces has four vertices. Since you do not need to close each polygon (i.e., the first and last vertices do not need to be the same), you can define this cube using a 4-by-6 matrix for each of the  $x$ -,  $y$ -, and  $z$ -coordinates.

x-coordinates	y-coordinates	z-coordinates
0 1 1 0 0 0	0 0 1 1 0 0	0 0 0 0 0 1
1 1 0 0 1 1	0 1 1 0 0 0	0 0 0 0 0 1
1 1 0 0 1 1	0 1 1 0 1 1	1 1 1 1 0 1
0 1 1 0 0 0	0 0 1 1 1 1	1 1 1 1 0 1

Face 1

Each column of the matrices specifies a different face. Note that while there are only eight vertices, you must specify 24 vertices to define all six faces. Since each face shares vertices with four other faces, you can define the patch more efficiently by defining each vertex only once and then specifying the order in which to connect these vertices to form each face. The patch Vertices and Faces properties define patches in just this way.

### Specifying Faces and Vertices

These matrices specify the cube using Vertices and Faces.

	Vertices			Faces			
	x	y	z				
1st vertex	0	0	0	1	2	6	5
2nd vertex	1	0	0	2	3	7	6
·	1	1	0	3	4	8	7
·	0	1	0	4	1	5	8
5th vertex	0	0	1	1	2	3	4
6th vertex	1	0	1	5	6	7	8
	1	1	1				

This data draws the first face by connecting vertices 1, 2, 6, and 5 in that order.

Using the `vertices/faces` technique can save a considerable amount of computer memory when patches contain a large number of faces. This technique requires the formal patch function syntax, which entails assigning values to the `Vertices` and `Faces` properties explicitly. For example,

```
patch('Vertices',vertex_matrix,'Faces',faces_matrix)
```

Since the formal syntax does not automatically assign face or edge colors, you must set the appropriate properties to produce patches with colors other than the default white face color and black edge color.

### Flat Face Color

Flat face color is the result of specifying one color per face. For example, using the `vertices/faces` technique and the `FaceVertexCData` property to define color, this statement specifies one color per face and sets the `FaceColor` property to flat.

```
patch('Vertices',vertex_matrix,'Faces',faces_matrix,...  
      'FaceVertexCData',hsv(6),'FaceColor','flat')
```

Since true color specified with the `FaceVertexCData` property has the same format as a MATLAB colormap (i.e., an  $n$ -by-3 array of RGB values), this example uses the `hsv` colormap to generate the six colors required for flat shading.

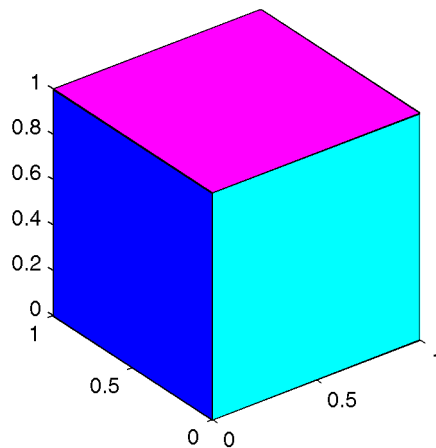

## Interpolated Face Color

Interpolated face color means the vertex colors of each face define a transition of color from one vertex to the next. To interpolate the colors between vertices, you must specify a color for each vertex and set the `FaceColor` property to `interp`.

```
patch('Vertices', vertex_matrix, 'Faces', faces_matrix, ...
      'FaceVertexCData', hsv(8), 'FaceColor', 'interp')
```

Changing to the standard 3-D view and making the axis square,

```
view(3); axis square
```

produces a cube with each face colored by interpolating the vertex colors.

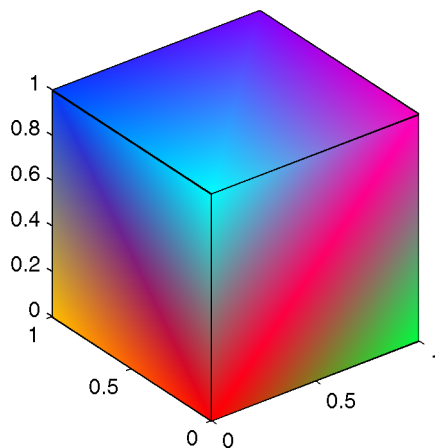

To specify the same coloring using the `x, y, z, c` technique, `c` must be an  $m$ -by- $n$ -by-3 array, where the dimensions of `x`, `y`, and `z` are  $m$ -by- $n$ .

This diagram shows the correspondence between the `FaceVertexCData` and `CData` properties.





## Specifying Patch Coloring

Patch objects employ a coloring scheme that is basically different from that used by surface objects in that patches do not automatically generate color data based on the value of the  $z$ -coordinate at each vertex. You must explicitly specify patch coloring, or MATLAB uses the default white face color and black edge color.

Patch coloring methods provide a means to display pictures of real-world objects with information superimposed on them through the use of color. For example a picture of an airplane wing can be colored to indicate the air pressure across its surface.

This table summarizes the patch properties that control color (exclusive of those used when light sources are present). See the patch property descriptions in the online MATLAB Function Reference for a complete list of properties.

Property	Purpose
CData	Specify single, per face, or per vertex colors in conjunction with $x$ , $y$ , and $z$ data
CDataMapping	Specifies whether color data is scaled or used directly as indices into the figure colormap
FaceVertexCData	Specify single, per face, or per vertex colors in conjunction with faces and vertices data
EdgeColor	Specifies whether edges are invisible, a single color, a flat color determined by vertex colors, or interpolated colors determined by vertex colors
FaceColor	Specifies whether faces are invisible, a single color, a flat color determined by vertex colors, or interpolated colors determined by vertex colors
MarkerEdgeColor	Specifies the color of the marker, or the edge color for filled markers

<b>Property</b>	<b>Purpose</b>
MarkerFaceColor	Specifies the fill color for markers that are closed shapes

## Face and Edge Coloring

You can specify patch face coloring by defining:

- A single color for all faces
- One color for each face, which is used for flat coloring
- One color for each vertex, which is used for interpolated coloring

Specify the face color using either the `CData` property, if you are using  $x$ ,  $y$ , and  $z$ -coordinates or the `FaceVertexCData` property, if you are specifying vertices and faces.

Each patch face has a bounding edge, which you can color as:

- A single color for all edges
- A flat color defined by the color of the vertex that precedes the edge
- Interpolated colors determined by the two vertices that bound the edge

Note that patch edge colors can be flat or interpolated only when you specify a color for each vertex. For flat edge coloring, MATLAB uses the color of the vertex preceding the edge to determine the color of the edge. The order in which you specify the vertices establishes which vertex colors a particular edge.

### Example – Specifying Flat Edge and Face Coloring

These statements create a square patch.

```
v = [0 0 0;1 0 0;1 1 0;0 1 0];
f = [1 2 3 4];
fvc = [1 0 0;0 1 0;1 0 1;1 1 0];
patch('Vertices',v,'Faces',f,'FaceVertexCData',fvc,...
      'FaceColor','flat','EdgeColor','flat',...
      'Marker','o','MarkerFaceColor','flat')
```

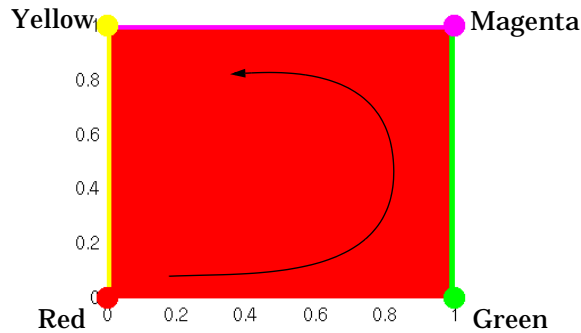

The Faces property value, [1 2 3 4], determines the order in which MATLAB connects the vertices. In this case, the order is red, green, magenta, and yellow. If you change this order, the results can be quite different. For example, specifying the Faces property as,

```
f = [4 3 2 1];
```

changes the order to yellow, magenta, green, and red. Note that changing the order not only changes the color of the edges, but also the color of the face, which is the color of the first vertex specified.

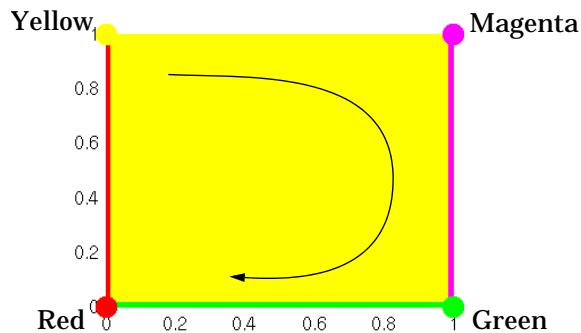

### Coloring Edges with Shared Vertices

Each patch face is bound by edges, which are line segments that connect the vertices. When patches have multiple faces that share vertices, some of the

edges may overlap. In such cases, the edges of the most recently drawn face overlay previously drawn edges.

For example, this illustration shows a patch with four faces and flat colored edges (FaceColor set to none, EdgeColor set to flat).

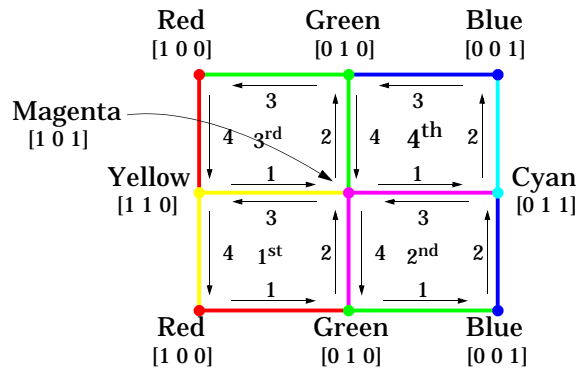

The arrows indicate the order in which each edge is drawn in the first, second, third, and fourth face. The color at each vertex determines the color of the edge that follows it. Notice how the second edge in the first face would be green except that the second face drew its fourth edge from the magenta vertex. You can see similar effects in all shared edges.

For EdgeColor set to interp, MATLAB interpolates colors between adjacent vertices. In this case, the order in which you specify the vertices does not affect the edge color.

## How MATLAB Interprets Patch Color Data

MATLAB interprets the color data in one of two ways:

- Indexed color data – numerical values that are mapped to colors defined in the figure colormap
- Truecolor data – RGB triples that define colors explicitly and do not make use of the figure colormap

The dimensions of the color data (CData or FaceVertexCData) determine how MATLAB interprets it. If you specify only one numeric value per patch, per face, or per vertex, then MATLAB interprets the data as indexed. If there are three numeric values per patch, face, or vertex, then MATLAB interprets the data as RGB values.

### Indexed Color Data

MATLAB interprets indexed color data as either values to scale before mapping to the colormap, or directly as indices into the colormap. You control the interpretation by setting the CDataMapping property. The default is to scale the data.

### Scaled Color

By default, MATLAB scales the color data so that the minimum value maps to the first color in the colormap, the maximum value maps to the last color in the colormap, and values in between are linearly transformed to span the colormap. This enables you to use colormaps of different sizes without changing your data and to use data in any range of values without changing the colormap.

For example, the following patch has eight triangular faces with a total of 24 (nonunique) vertices. The color data are integers that range from one to 24, but could be any values.

The variable `c` contains the color data. It is a 3-by-8 matrix, with each column specifying the colors for the three vertices of each face.

```
c =  
    1     4     7    10    13    16    19    22  
    2     5     8    11    14    17    20    23  
    3     6     9    12    15    18    21    24
```

The color bar (`colorbar`) on the right side of the patch illustrates the colormap used and indicates with the vertical axis which color is mapped to the respective data value.

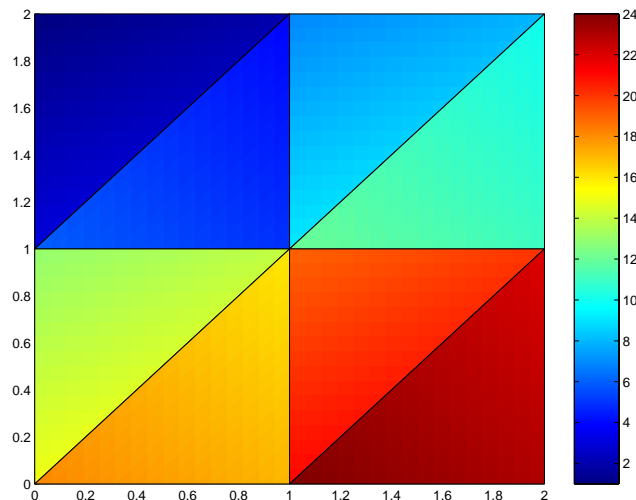

You can alter the mapping of color data to colormap entry using the `caxis` command. This command uses a two-element vector `[cmin cmax]` to specify what data values map to the beginning and end of the colormap, thereby shifting the color mapping.

By default, MATLAB sets `cmin` to the minimum value and `cmax` to the maximum value of the color data of all graphics objects within the axes. However, you can set these limits to span any range of values and thereby shift the color mapping. See “Calculating Color Limits” in the “Axes Properties” chapter for more information.

The color data does not need to be a sequential list of integers; it can be any matrix with dimensions matching the coordinate data. For example,

```
patch(x,y,z,rand(size(z)))
```

### Direct Color

If you set the patch `CDataMapping` property to `off`,

```
set(patch_handle, 'CDataMapping', 'off')
```

MATLAB interprets each color data value as a direct index into the colormap. That is, a value of 1 maps to the first color, a value of 2 maps to the second color, and so on.

The patch from the previous example would then use only the first 24 colors in the colormap.

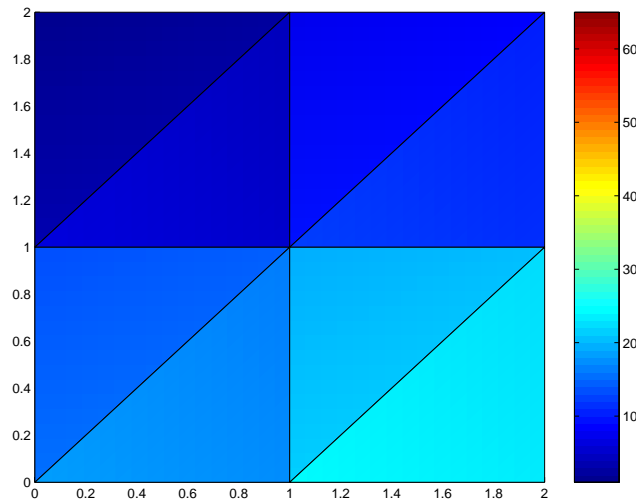

This example uses integer color data. However, if the values are not integers, MATLAB converts them according to these rules:

- If value is  $< 1$ , it maps to the first color in the colormap.
- If value is not an integer, it is rounded to the nearest integer towards zero.
- If value  $> \text{length}(\text{colormap})$ , it maps to the last color in the colormap.

Unscaled color data is more commonly used for images where there is typically a colormap associated with a particular image.



## Truecolor Patches

Truecolor is a means to specify a color explicitly with RGB values rather than pointing to an entry in the figure colormap. Truecolor generally provides a greater range of colors than can be defined in a colormap.

Using truecolor eliminates the mapping of data to colormap entries. On the other hand, you cannot change the coloring of the patch without redefining the color data (as opposed to just changing the colormap).

You can use truecolor on computers that do not have true color (24-bit) displays. In this case, MATLAB uses a special colormap designed to produce results that are as close as possible with the limited number of colors available. Properties control how MATLAB uses color on pseudocolor machines.

## Interpolating in Indexed Color Versus Truecolor

When you specify interpolated face coloring, MATLAB determines the color of each face by interpolating the vertex colors. The method of interpolation depends on whether you specified truecolor data or indexed color data.

With truecolor data, MATLAB interpolates the numeric RGB values defined for the vertices. This generally produces a smooth variation of color across the face. In contrast, indexed color interpolation uses only colors that are defined in the colormap. With certain colormaps, the results can be quite different.

To illustrate this difference, these two patches are defined with the same vertex colors. Circular markers indicate the yellow, red, and blue vertex colors.

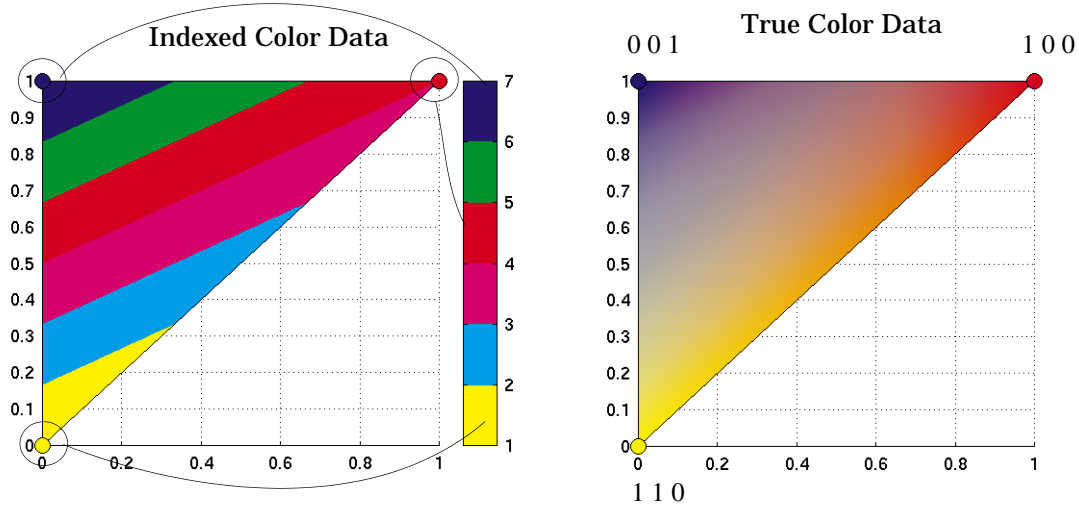

The patch on the left uses indexed colors obtained from the six-element colormap shown next to it. The color data maps the vertex colors to the colormap elements indicated in the picture. With this colormap, interpolating from the cyan vertex to the blue vertex can include only the colors green, red, yellow, and magenta, hence the banding.

Interpolation in RGB space makes no use of the colormap. It is simply the gradual transition from one numeric value to another. For example, interpolating from the cyan vertex to the blue vertex follows a progression similar to these values.

0 1 1, 0 0.9 1, 0 0.8 1, ... 0 0.2 1, 0 0.1 1, 0 0 1

In reality each pixel would be a different color so the incremental change would be much smaller than illustrated here.

# Volume Visualization Techniques

---

<b>Volume Visualization Topics</b> . . . . .	15-2
<b>Overview of Volume Visualization</b> . . . . .	15-3
<b>Volume Visualization Functions</b> . . . . .	15-5
<b>Visualizing Scalar Volume Data</b> . . . . .	15-7
<b>Visualizing MRI Data</b> . . . . .	15-8
<b>Exploring Volumes with Slice Planes</b> . . . . .	15-14
<b>Connecting Equal Values with Isosurfaces</b> . . . . .	15-19
<b>Isocaps Add Context to Visualizations</b> . . . . .	15-21
<b>Visualizing Vector Volume Data</b> . . . . .	15-25
<b>Stream Line Plots of Vector Data</b> . . . . .	15-30
<b>Displaying Curl with Stream Ribbons</b> . . . . .	15-32
<b>Displaying Divergence with Stream Tubes</b> . . . . .	15-34
<b>Creating Stream Particle Animations</b> . . . . .	15-37
<b>Vector Field Displayed with Cone Plots</b> . . . . .	15-40

## Volume Visualization Topics

This page presents a quick overview of the volume visualization topics discussed in this section.

- Overview of Volume Visualization – discusses the types of volume data you can visualize with MATLAB and introduces the techniques available.
- Volume Visualization Functions – provides a list of the functions used for volume visualization.
- Visualizing Scalar Volume Data – summarizes the techniques available for visualizing scalar volume data.
- Visualizing MRI Data – shows ways to visualize MRI data using 2- and 3-D contour slices, isosurfaces, isocaps, and lighting.
- Exploring Volumes with Slice Planes – illustrates the use of slice planes with scalar volume data.
- Connecting Equal Values with Isosurfaces – shows the use of isosurfaces to illustrate fluid data.
- Isocaps. Add Context to Visualizations – demonstrates the use of isocaps to improve the clarity of isosurface plots.
- Visualizing Vector Volume Data – summarizes the techniques available for visualizing vector volume data, including using scalar techniques, determining starting points for stream plots, and plotting subregions of volumes.
- Stream Line Plots of Vector Data – demonstrates the use of stream lines, slice planes, and contours lines used in conjunction.
- Displaying Curl with Stream Ribbons – illustrates the use of stream ribbon plots to display the curl of a vector field.
- Displaying Divergence with Stream Tubes – illustrates the use of stream tube plots to display the divergence of a vector field. Slice planes and contour lines are used to enhance the visualization.
- Creating Stream Particle Animations – uses a combination of stream lines and stream particles to create an animation showing wind currents.
- Vector Field Displayed with Cone Plots – applies a combination of cone plots, isosurfaces, lighting, and camera placement to visualize a vector field.

## Overview of Volume Visualization

Volume visualization is the creation of graphical representations of data sets that are defined on three-dimensional grids. Volume data sets are characterized by multidimensional arrays of scalar or vector data. These data are typically defined on lattice structures representing values sampled in 3-D space. There are two basic types of volume data:

- *Scalar volume data* contains single values for each point.
- *Vector volume data* contains two or three values for each point, defining the components of a vector.

### Examples of Volume Data

An example of scalar volume data is that produced by the `flow` M-file. The flow data represents the speed profile of a submerged jet within an infinite tank.

Typing

```
[x,y,z,v] = flow;
```

produces four 3-D arrays. The `x`, `y`, and `z` arrays specify the coordinates of the scalar values in the array `v`.

The `wind` data set is an example of vector volume data that represents air currents over North America. You can load this data in the MATLAB workspace with the command

```
load wind
```

This data set comprises six 3-D arrays: `x`, `y`, and `z` are the coordinate data for the arrays `u`, `v`, and `w`, which are the vector components for each point in the volume.

### Selecting Visualization Techniques

The techniques you select to visualize volume data depend on what type of data you have and what you want to learn. In general, scalar data is best viewed with isosurfaces, slice planes, and contour slices. Vector data represents both a magnitude and direction at each point, which is best displayed by stream lines (particles, ribbons, and tubes), cone plots, and arrow plots. Most visualizations, however, employ a combination of techniques to best reveal the content of the data.

The material in these sections describe how to apply a variety of techniques to typical volume data.

## **Steps to Create a Volume Visualization**

Creating an effective visualization requires a number of steps to compose the final scene. These steps fall into four basic categories:

- 1 Determine the characteristics of your data.** Graphing volume data usually requires knowledge of the range of both the coordinates and the data values.
- 2 Select an appropriate plotting routine.** The information in this section helps you select the right methods.
- 3 Define the view.** The information conveyed by a complex three-dimensional graph can be greatly enhanced through careful composition of the scene. Viewing techniques include adjusting camera position, specifying aspect ratio and project type, zooming in or out, and so on.
- 4 Add lighting and specify coloring.** Lighting is an effective means to enhance the visibility of surface shape and to provide a three-dimensional perspective to volume graphs. Color can convey data values, both constant and varying.

## Volume Visualization Functions

MATLAB provides functions that enable you to apply a variety of volume visualization techniques. The following tables group these functions into two categories based on the type of data (scalar or vector) each is designed to work with. The reference page for each function provides examples of the intended use.

### Functions Used with Scalar Volume Data

Functions	Purpose
<code>contourslice</code>	Draw contours in volume slice planes
<code>isocaps</code>	Compute isosurface end-cap geometry
<code>isocolors</code>	Compute the colors of isosurface vertices
<code>isonormals</code>	Compute normals of isosurface vertices
<code>isosurface</code>	Extract isosurface data from volume data
<code>patch</code>	Create a patch (multipolygon) graphics object
<code>reducepatch</code>	Reduce the number of patch faces
<code>reducevolume</code>	Reduce the number of elements in a volume data set
<code>shrinkfaces</code>	Reduce the size of each patch face
<code>slice</code>	Draw slice planes in volume
<code>smooth3</code>	Smooth 3-D data
<code>surf2patch</code>	Convert surface data to patch data
<code>subvolume</code>	Extract subset of volume data set

**Functions Used with Vector Volume Data**

<b>Functions</b>	<b>Purpose</b>
coneplot	Plot velocity vectors as cones in 3-D vector fields
curl	Compute the curl and angular velocity of a 3-D vector field
divergence	Compute the divergence of a 3-D vector field
interpstreamspeed	Interpolate streamline vertices from vector-field magnitudes
streamline	Draw stream lines from 2-D or 3-D vector data
streamparticles	Draw stream particles from vector volume data
streamribbon	Draw stream ribbons from vector volume data
streamslice	Draw well-spaced stream lines from vector volume data
streamtube	Draw stream tubes from vector volume data
stream2	Compute 2-D stream line data
stream3	Compute 3-D stream line data
volumebounds	Return coordinate and color limits for volume (scalar and vector)



## Visualizing Scalar Volume Data

Typical scalar volume data is composed of a 3-D array of data and three coordinate arrays of the same dimensions. The coordinate arrays specify the x, y, and z coordinates for each data point.

The units of the coordinates depend on the type of data. For example, flow data might have coordinate units of inches and data units of psi.

### Techniques for Visualizing Scalar Data

MATLAB supports a number of functions that are useful for visualizing scalar data.

- Slice planes provide a way to explore the distribution of data values within the volume by mapping values to colors. You can orient slice planes at arbitrary angles, as well as use nonplanar slices. (For illustrations of how to use slice planes, see `slice`, a volume slicing example, and slice planes used to show context.) You can specify the data used to color isosurfaces, enabling you to display different information in color and surface shape (see `isocolors`).
- Contour slices are contour plots drawn at specific coordinates within the volume. Contour plots enable you to see where in a given plane the data values are equal. See `contourslice` and MRI data for an example
- Isosurfaces are surfaces constructed by using points of equal value as the vertices of patch graphics objects.

## Visualizing MRI Data

An example of scalar data includes Magnetic Resonance Imaging (MRI) data. This data typically contains a number of slice planes taken through a volume, such as the human body. MATLAB includes an MRI data set that contains 27 image slices of a human head. Some useful techniques for visualizing this data include displaying the data as:

- A series of 2-D images representing slices through the head
- 2-D and 3-D contour slices taken at arbitrary locations within the data
- An isosurface with isocaps showing a cross section of the interior

### Changing the Data Format

The MRI data, `D`, is stored as a 128-by-128-by-1-by-27 array. The third array dimension is used typically for the image color data. However, since these are indexed images (a colormap, `map`, is also loaded) there is no information in the third dimension, which you can remove using the `squeeze` command. The result is a 128-by-128-by-27 array.

The first step is to load the data and transform the data array from 4-D to 3-D.

```
load mri
D = squeeze(D);
```

### Displaying Images of MRI Data

To display one of the MRI images, use the `image` command, indexing into the data array to obtain the eighth image. Then adjust axis scaling, and install the MRI colormap, which was loaded along with the data.

```
image_num = 8;
image(D(:,:,image_num))
axis image
colormap(map)
```

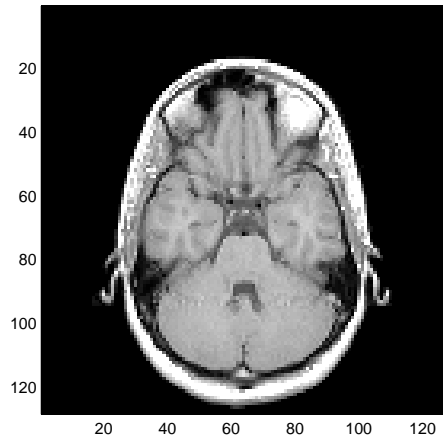

Save the  $x$  and  $y$  axis limits for use in the next part of the example.

```
x = xlim;  
y = ylim;
```

### Displaying a 2-D Contour Slice

You can treat this MRI data as a volume because it is a collection of slices taken progressively through the 3-D object. Use `contourslice` to display a contour plot of a slice of the volume. To create a contour plot with the same orientation and size as the image created in the first part of this example, adjust the  $y$ -axis direction (`axis`), set the limits (`xlim`, `ylim`), and set the data aspect ratio (`daspect`).

```
contourslice(D,[],[],image_num)  
axis ij  
xlim(x)  
ylim(y)  
daspect([1,1,1])  
colormap('default')
```

This contour plot uses the figure colormap to map color to contour value.

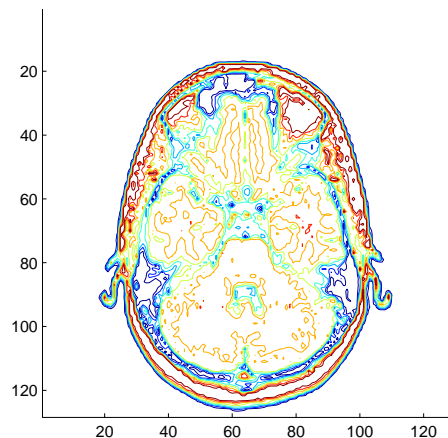

### Displaying 3-D Contour Slices

Unlike images, which are 2-D objects, contour slices are 3-D objects that you can display in any orientation. For example, you can display four contour slices in a 3-D view. To improve the visibility of the contour line, increase the `LineWidth` to 2 points (one point equals 1/72 of an inch).

```
phandles = contourslice(D,[],[],[1,12,19,27],8);  
view(3); axis tight  
set(phandles,'LineWidth',2)
```

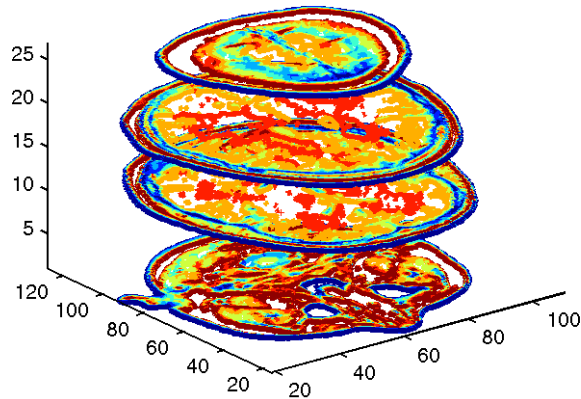

### Displaying an Isosurface

You can use `isosurfaces` to display the overall structure of a volume. When combined with `isocaps`, this technique can reveal information about data on the interior of the isosurface.

First, smooth the data with `smooth3`; then use `isosurface` to calculate the isodata. Use `patch` to display this data as a graphics object.

```
Ds = smooth3(D);
hiso = patch(isosurface(Ds,5),...
    'FaceColor',[1,.75,.65],...
    'EdgeColor','none');
```

### Adding an Isocap to Show a Cutaway Surface

Use `isocaps` to calculate the data for another patch that is displayed at the same isovalue (5) as the surface. Use the unsmoothed data (`D`) to show details of the interior. You can see this as the sliced-away top of the head.

```
hcap = patch(isocaps(D,5),...
    'FaceColor','interp',...
    'EdgeColor','none');
colormap(map)
```

### Defining the View

Define the view and set the aspect ratio (view, axis, daspect).

```
view(45,30)
axis tight
daspect([1,1,.4])
```

### Add Lighting

Add lighting and recalculate the surface normals based on the gradient of the volume data, which produces smoother lighting (camlight, lighting, isonormals). Increase the AmbientStrength property of the isocap to brighten the coloring without affecting the isosurface. Set the SpecularColorReflectance of the isosurface to make the color of the specular reflected light closer to the color of the isosurface; then set the SpecularExponent to reduce the size of the specular spot.

```
lightangle(45,30);
set(gcf,'Renderer','zbuffer'); lighting phong
isonormals(Ds,hiso)
set(hcap,'AmbientStrength',.6)
set(hiso,'SpecularColorReflectance',0,'SpecularExponent',50)
```

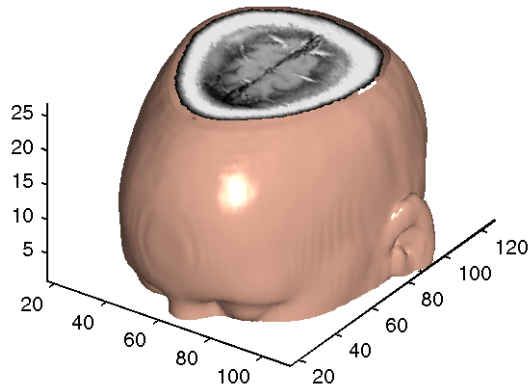

The `isocap` uses interpolated face coloring, which means the figure colormap determines the coloring of the patch. This example uses the colormap supplied with the data.

To display isocaps at other data values, try changing the isosurface value or use the `subvolume` command. See the `isocaps` and `subvolume` reference pages for examples.

## Exploring Volumes with Slice Planes

A slice plane (which does not have to be planar) is a surface that takes on coloring based on the values of the volume data in the region where the slice is positioned. Slice planes are useful for probing volume data sets to discover where interesting regions exist, which you can then visualize with other types of graphs (see the `slice` example). Slice planes are also useful for adding a visual context to the bound of the volume when other graphing methods are also used (see `coneplot` and the “Streamline Plots of Vector Data” section in this chapter for examples).

Use the `slice` command to create slice planes.

### Example – Slicing Fluid Flow Data

This example slices through a volume generated by the `flow` M-file.

#### 1. Investigate the Data

Generate the volume data with the command

```
[x,y,z,v] = flow;
```

Determine the range of the volume by finding the minimum and maximum of the coordinate data.

```
xmin = min(x(:));  
ymin = min(y(:));  
zmin = min(z(:));
```

```
xmax = max(x(:));  
ymax = max(y(:));  
zmax = max(z(:));
```

#### 2. Create a Slice Plane at an Angle to the X-Axes

To create a slice plane that does not lie in an axes plane, first define a surface and rotate it to the desired orientation. This example uses a surface that has the same `x` and `y` coordinates as the volume.

```
hslice = surf(linspace(xmin,xmax,100),...  
             linspace(ymin,ymax,100),...  
             zeros(100));
```



Rotate the surface by -45 degrees about the x axis and save the surface XData, YData, and ZData to define the slice plane; then delete the surface.

```
rotate(hslice, [-1,0,0], -45)
xd = get(hslice, 'XData');
yd = get(hslice, 'YData');
zd = get(hslice, 'ZData');
delete(hslice)
```

### 3. Draw the Slice Planes

Draw the rotated slice plane, setting the FaceColor to interp so that it is colored by the figure colormap and set the EdgeColor to none. Increase the DiffuseStrength to .8 to make this plane shine more brightly after adding a light source.

```
h = slice(x,y,z,v,xd,yd,zd);
set(h, 'FaceColor', 'interp', ...
      'EdgeColor', 'none', ...
      'DiffuseStrength', .8)
```

Set hold to on and add three more orthogonal slice planes at xmax, ymax, and zmin to provide a context for the first plane, which slices through the volume at an angle.

```
hold on
hx = slice(x,y,z,v,xmax,[],[]);
set(hx, 'FaceColor', 'interp', 'EdgeColor', 'none')

hy = slice(x,y,z,v,[],ymax,[]);
set(hy, 'FaceColor', 'interp', 'EdgeColor', 'none')

hz = slice(x,y,z,v,[],[],zmin);
set(hz, 'FaceColor', 'interp', 'EdgeColor', 'none')
```

### 4. Define the View

To display the volume in correct proportions, set the data aspect ratio to [1,1,1] (daspect). Adjust the axis to fit tightly around the volume (axis) and turn on the box to provide a sense of a 3-D object. The orientation of the axes can be selected initially using rotate3d to determine the best view.

Zooming in on the scene provides a larger view of the volume (camzoom). Selecting a projection type of perspective gives the rectangular solid more natural proportions than the default orthographic projection (camproj).

```
daspect([1,1,1])  
axis tight  
box on  
view(-38.5,16)  
camzoom(1.4)  
camproj perspective
```

### 5. Add Lighting and Specify Colors

Adding a light to the scene makes the boundaries between the four slice planes more obvious since each plane forms a different angle with the light source (lightangle). Selecting a colormap with only 24 colors (the default is 64) creates visible gradations that help indicate the variation within the volume.

```
lightangle(-45,45)  
colormap (jet(24))  
set(gcf, 'Renderer', 'zbuffer')
```

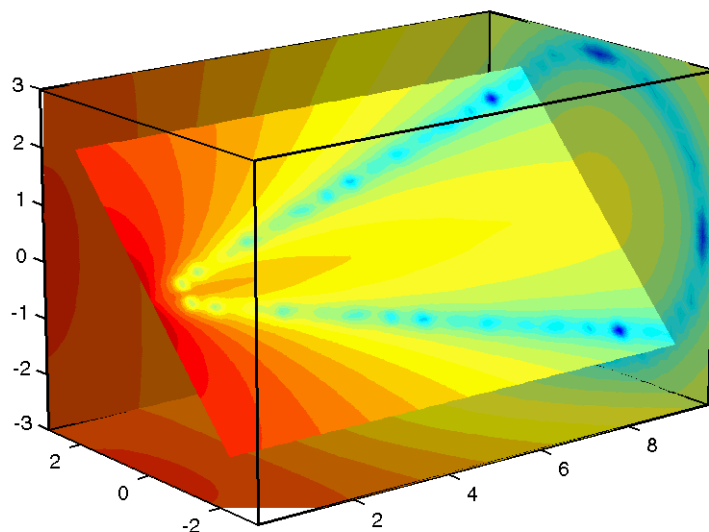

## Modifying the Color Mapping

The current colormap determines the coloring of the slice planes. This enables you to change the slice plane coloring by:

- Changing the colormap
- Changing the mapping of data value to color

Suppose, for example, you are interested in data values only between -5 and 2.5 and would like to use a colormap that mapped lower values to reds and higher values to blues (that is, the opposite of the default jet colormap).

### Customizing the Colormap

The first step is to flip the colormap (`colormap, flipud`).

```
colormap (flipud(jet(24)))
```

### Adjusting the Color Limits

Adjusting the color limits enables you to emphasize any particular data range of interest. Adjust the color limits to range from -5 to 2.4832 so that any value lower than the value -5 (the original data ranged from -11.5417 to 2.4832) is mapped into the same color. (See `caxis` and the "Axis Color Limits – The CLim Property" section in the "Axes Properties" chapter for an explanation of color mapping.)

```
caxis([-5,2.4832])
```

Adding a color bar provides a key for the data to color mapping.

```
colorbar('horiz')
```

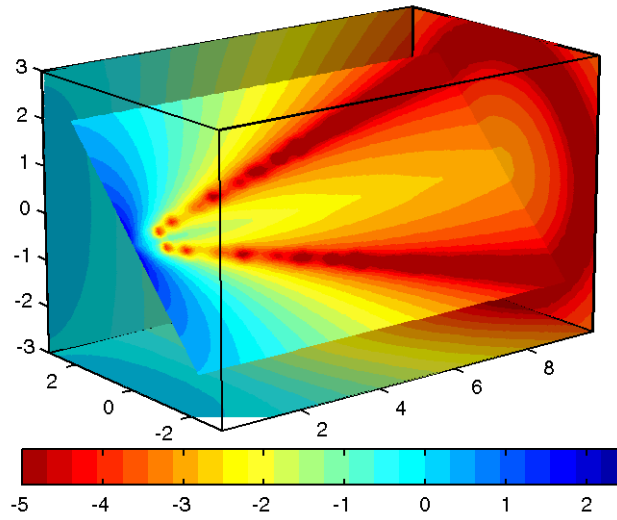

## Connecting Equal Values with Isosurfaces

Isosurfaces are constructed by creating a surface within the volume that has the same value at each vertex. Isosurface plots are similar to contour plots in that they both indicate where values are equal.

Isosurfaces are useful to determine where in a volume a certain threshold value is reached or to observe the spacial distribution of data by selecting various isovalues at which to generate a plot. The isovalue must lie within the range of the volume data.

Create isosurfaces with the `isosurface` and `patch` commands.

### Example – Isosurfaces in Fluid Flow Data

This example creates isosurfaces in a volume generated by the `flow` M-file. Generate the volume data with the command,

```
[x,y,z,v] = flow;
```

To select the isovalue, determine the range of values in the volume data.

```
min(v(:))
ans =
    -11.5417
max(v(:))
ans =
     2.4832
```

Through exploration, you can select isovalues that reveal useful information about the data. Once selected, use the isovalue to create the isosurface:

- Use `isosurface` to generate data that you can pass directly to `patch`.
- Recalculate the surface normals from the gradient of the volume data to produce better lighting characteristics (`isonormals`).
- Set the `patch` `FaceColor` to red and the `EdgeColor` to none to produce a smoothly lit surface.
- Adjust the view and add lighting (`daspect`, `view`, `camlight`, `lighting`).

```
hpatch = patch(isosurface(x,y,z,v,0));
isonormals(x,y,z,v,hpatch)
set(hpatch,'FaceColor','red','EdgeColor','none')
```

```
daspect([1,4,4])  
view([-65,20])  
axis tight  
camlight left;  
set(gcf,'Renderer','zbuffer'); lighting phong
```

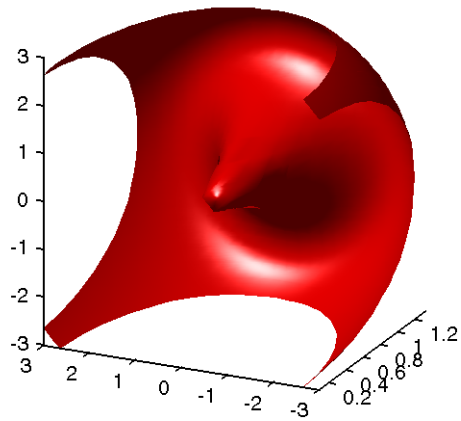

## Isocaps Add Context to Visualizations

Isocaps are planes that are fitted to the limits of an isosurface to provide a visual context for the isosurface. Isocaps show a cross-sectional view of the interior of the isosurface for which it provides an *end cap*.

The following two pictures illustrate the use of isocaps. The first is an isosurface without isocaps.

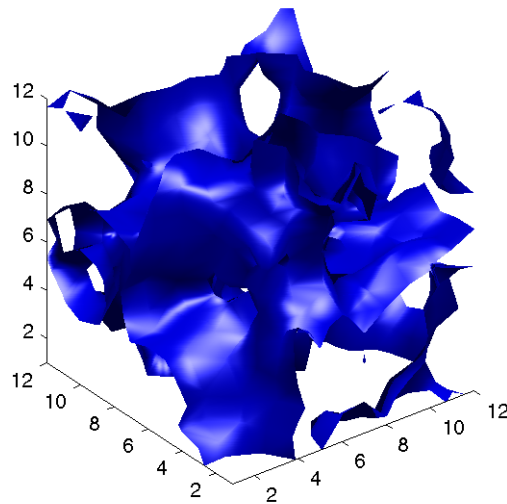

The second picture shows the effect of adding isocaps to the same isosurface.

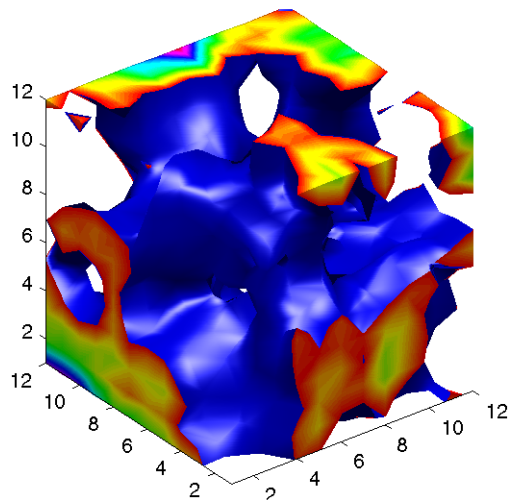

### Other Isocap Applications

Some additional applications of isocaps are:

- Isocaps used to show the interior of a cut-away volume.
- Isocaps used to cap the end of a volume that would otherwise appear empty.
- Isocaps used to enhance the visibility of the isosurface limits.

### Defining Isocaps

Isocaps, like isosurfaces, are created as patch graphics objects. Use the `isocaps` command to generate the data to pass to `patch`. For example,

```
patch(isocaps(voldata,isoval),...  
      'FaceColor','interp',...  
      'EdgeColor','none')
```

creates isocaps for the scalar volume data `voldata` at the value `isoval`. You should create the isosurface using the same volume data and isovalue to ensure that the edges of the isocaps *fit* the isosurface.



Setting the patch `FaceColor` property to `interp` results in a coloring that maps the data values spanned by the isocap to `colormap` entries. You can also set other patch properties to control the effects of lighting and coloring on the isocaps.

## Example - Adding Isocaps to an Isosurface

This example illustrates how to set coloring and lighting characteristics when working with isocaps. There are four basic steps:

- Generate and process your volume data.
- Create the isosurface and isocaps and set patch properties to control the coloring and lighting.
- Specify the view.
- Add lights to the scene.

### 1. Prepare the Data

This example uses a 3-D array of random (`rand`) data to define the volume data. The data is then smoothed (`smooth3`).

```
data = rand(12,12,12);
data = smooth3(data,'box',5);
```

### 2. Create the Isosurface and Set Properties

Use `isosurface` and `patch` to create the isosurface and set coloring and lighting properties. Reduce the `AmbientStrength`, `SpecularStrength`, and `DiffuseStrength` of the reflected light to compensate for the brightness of the two light sources used to provide more uniform lighting.

Recalculate the vertex normals of the isosurface to produce smoother lighting (`isonormals`).

```
isoval = .5;
h = patch(isosurface(data,isoval),...
    'FaceColor','blue',...
    'EdgeColor','none',...
    'AmbientStrength',.2,...
    'SpecularStrength',.7,...
    'DiffuseStrength',.4);
isonormals(data,h)
```

### 3. Create the Isocaps and Set Properties

Define the isocaps using the same data and isovalue as the isosurface. Specify interpolated coloring and select a colormap that provides better contrasting colors with the blue isosurface than those in the default colormap (`colormap`).

```
patch(isocaps(data, isoval), ...  
      'FaceColor', 'interp', ...  
      'EdgeColor', 'none')  
colormap hsv
```

### 4. Specify the View

Set the data aspect ratio to `[1, 1, 1]` so that the displays in correct proportions (`daspect`). Eliminate white space within the axis and set the view to 3-D (axis `tight`, `view`).

```
daspect([1, 1, 1])  
axis tight  
view(3)
```

### 5. Add Lighting

To add fairly uniform lighting, but still take advantage of the ability of light sources to make visible subtle variations in shape, this example uses two lights; one to the left and one to the right of the camera (`camlight`). Use Phong lighting to produce the smoothest variation of color (`lighting`). Phong lighting requires the `zbuffer` renderer.

```
camlight right  
camlight left  
set(gcf, 'Renderer', 'zbuffer');  
lighting phong
```

## Visualizing Vector Volume Data

Vector volume data contains more information than scalar data because each coordinate point in the data set has three values associated with it. These values define a vector that represents both a magnitude and a direction. The velocity of fluid flow is an example of vector data.

MATLAB supports a number of techniques that are useful for visualizing vector data:

- Stream lines trace the path that a massless particle immersed in the vector field would follow.
- Stream particles are markers that trace stream lines and are useful for creating stream line animations.
- Stream ribbons are similar to stream lines, except that the width of the ribbons enable them to indicate twist. Stream ribbons are useful to indicate curl angular velocity.
- Stream tubes are similar to stream lines, but you can also control the width of the tube. Stream tubes are useful for displaying the divergence of a vector field.
- Cone plots represent the magnitude and direction of the data at each point by displaying a conical arrowhead or an arrow.

It is typically the case that these functions best elucidate the data when used in conjunction with other visualization techniques, such as contours, slice planes, and isosurfaces. The examples in this section illustrate some of these techniques.

### Using Scalar Techniques with Vector Data

Visualization techniques such as contour slices, slice planes, and isosurfaces require scalar volume data. You can use these techniques with vector data by taking the magnitude of the vectors. For example, the `wind` data set returns three coordinate arrays and three vector component arrays, `u`, `v`, `w`. In this case, the magnitude of the velocity vectors equals the wind speed at each corresponding coordinate point in the volume.

```
wind_speed = sqrt(u.^2 + v.^2 + w.^2);
```

The array `wind_speed` contains scalar values for the volume data. The usefulness of the information produced by this approach, however, depends on what physical phenomena is represented by the magnitude of your vector data.

## Specifying Starting Points for Stream Plots

Stream plots (stream lines, ribbons, tubes, and cones or arrows) illustrate the flow of a 3-D vector field. The MATLAB stream plotting routines (`streamline`, `streamribbon`, `streamtube`, `coneplot`, `stream2`, `stream3`) all require you to specify the point at which you want to begin each stream trace.

### Determining the Starting Points

Generally, knowledge of your data's characteristics help you select the starting points. Information such as the primary direction of flow and the range of the data coordinates helps you decide where to evaluate the data.

The `streamslice` function is useful for exploring your data. For example, these statements draw a slice through the vector field at a `z` value midway in the range.

```
load wind
zmax = max(z(:)); zmin = min(z(:));
streamslice(x,y,z,u,v,w,[],[],(zmax-zmin)/2)
```

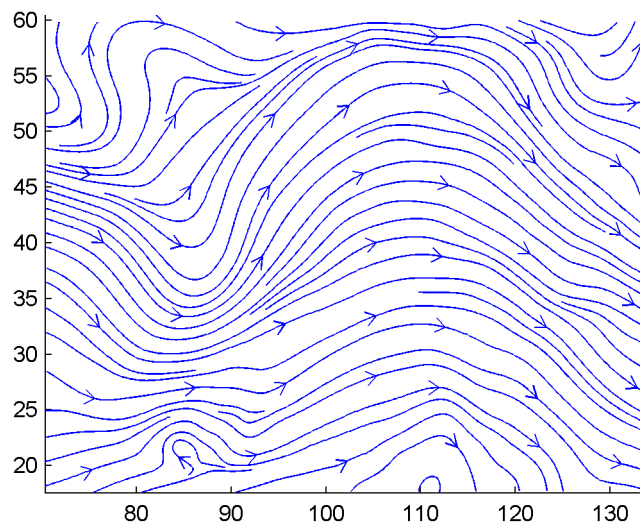

This stream slice plot indicates that the flow is in the positive x direction and also enables you to select starting points in both x and y. You could create similar plots that slice the volume in the x-z plane or the y-z plane to gain further insight into your data's range and orientation.

### Specifying Arrays of Starting-Point Coordinates

To specify the starting point for one stream line, you need the x-, y-, and z-coordinates of the point. The `meshgrid` command provides a convenient way to create arrays of starting points. For example, you could select the following starting points from the wind data displayed in the previous stream slice.

```
[sx,sy,sz] = meshgrid(80,20:10:50,0:5:15);
```

This statement defines the starting points as all lying on  $x = 80$ ,  $y$  ranging from 20 to 50, and  $z$  ranging from 0 to 15. You can use `plot3` to display the locations.

```
plot3(sx(:),sy(:),sz(:),'*r');
axis(volumebounds(x,y,z,u,v,w))
grid; box; daspect([2 2 1])
```

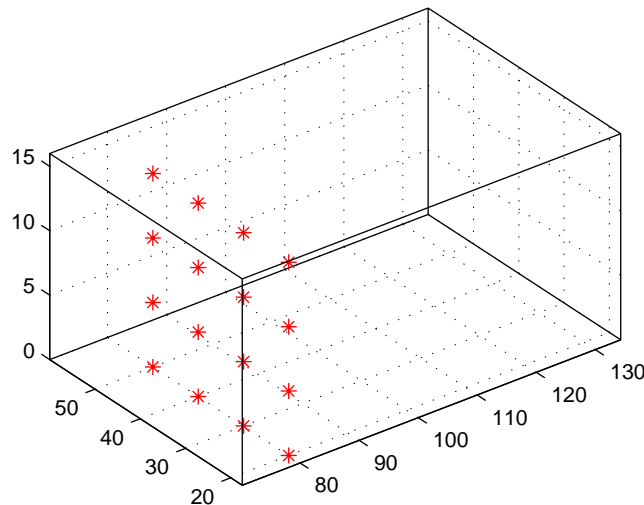

You do not need to use 3-D arrays, such as those returned by `meshgrid`, but the size of each array must be the same, and `meshgrid` provides a convenient way to generate arrays when you do not have an equal number of unique values in

each coordinate. You can also define starting-point arrays as column vectors. For example, `meshgrid` returns 3-D arrays.

```
[sx,sy,sz] = meshgrid(80,20:10:50,0:5:15);
whos
Name      Size      Bytes  Class
sx        4x1x4      128    double array
sy        4x1x4      128    double array
sz        4x1x4      128    double array
```

In addition, you could use 16-by-1 column vectors with the corresponding elements of the three arrays comprising the coordinates of each starting point. (This is the equivalent of indexing the values returned by `meshgrid` as `sx(:)`, `sy(:)`, and `sz(:)`.)

For example, adding the stream lines produces

```
streamline(x,y,z,u,v,w,sx(:),sy(:),sz(:))
```

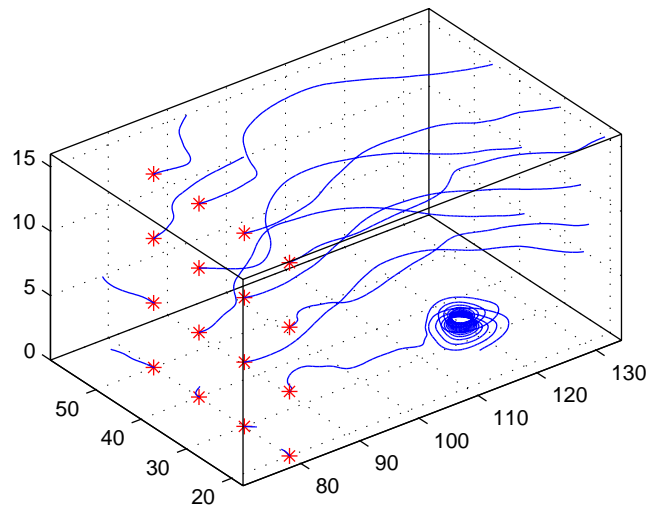

## Accessing Subregions of Volume Data

The `subvolume` function provides a simple way to access subregions of a volume data set. `subvolume` enables you to select regions of interest based on limits rather than using the colon operator to index into the 3-D arrays that define

volumes. Consider the following two approaches to creating the data for a subvolume – indexing with the colon operator and using subvolume.

### Indexing with the Colon Operator

When you index the arrays, you work with values that specify the elements in each dimension of the array.

```
load wind
xsub = x(1:10,20:30,1:7);
ysub = y(1:10,20:30,1:7);
zsub = z(1:10,20:30,1:7);
usub = u(1:10,20:30,1:7);
vsub = v(1:10,20:30,1:7);
wsub = w(1:10,20:30,1:7);
```

### Using the subvolume Function

subvolume enables you to use coordinate values that you can read from the axes. For example,

```
lims = [100.64 116.67 17.25 28.75 -0.02 6.86];
[xsub,ysub,zsub,usub,vsub,wsub] = subvolume(x,y,z,u,v,w,lims);
```

You can then use the subvolume data as inputs to any function requiring vector volume data.

## Stream Line Plots of Vector Data

MATLAB includes a vector data set called `wind` that represents air currents over North America. This example uses a combination of techniques:

- Stream lines to trace the wind velocity
- Slice planes to show cross-sectional views of the data
- Contours on the slice planes to improve the visibility of slice-plane coloring

### 1. Determine the Range of the Coordinates

Load the data and determine minimum and maximum values to locate the slice planes and contour plots (`load`, `min`, `max`).

```
load wind
xmin = min(x(:));
xmax = max(x(:));
ymax = max(y(:));
zmin = min(z(:));
```

### 2. Add Slice Planes for Visual Context

Calculate the magnitude of the vector field (which represents wind speed) to generate scalar data for the `slice` command. Create slice planes along the `x`-axis at `xmin`, 100, and `xmax`, along the `y`-axis at `ymax`, and along the `z`-axis at `zmin`. Specify interpolated face coloring so the slice coloring indicates wind speed, and do not draw edges (`sqrt`, `slice`, `FaceColor`, `EdgeColor`).

```
wind_speed = sqrt(u.^2 + v.^2 + w.^2);
hsurfaces = slice(x,y,z,wind_speed,[xmin,100,xmax],ymax,zmin);
set(hsurfaces,'FaceColor','interp','EdgeColor','none')
```

### 3. Add Contour Lines to the Slice Planes

Draw light gray contour lines on the slice planes to help quantify the color mapping (`contourslice`, `EdgeColor`, `LineWidth`).

```
hcont = ...
contourslice(x,y,z,wind_speed,[xmin,100,xmax],ymax,zmin);
set(hcont,'EdgeColor',[.7,.7,.7],'LineWidth',.5)
```



#### 4. Define the Starting Points for the Stream Lines

In this example, all stream lines start at an x-axis value of 80 and span the range 20 to 50 in the y direction and 0 to 15 in the z direction. Save the handles of the stream lines and set the line width and color (meshgrid, streamline, LineWidth, Color).

```
[sx,sy,sz] = meshgrid(80,20:10:50,0:5:15);  
hlines = streamline(x,y,z,u,v,w,sx,sy,sz);  
set(hlines,'LineWidth',2,'Color','r')
```

#### 5. Define the View

Set up the view, expanding the z-axis to make it easier to read the graph (view, daspect, axis).

```
view(3)  
daspect([2,2,1])  
axis tight
```

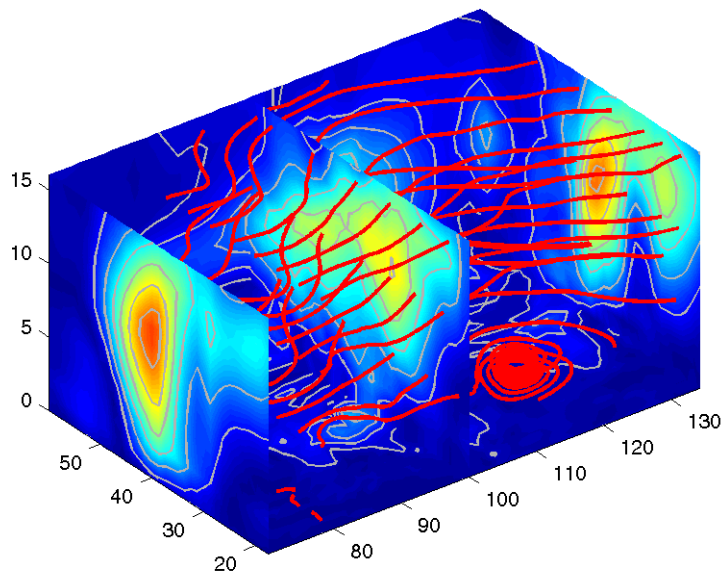

See coneplot for an example of the same data plotted with cones.

## Displaying Curl with Stream Ribbons

Stream ribbons illustrate direction of flow, similar to stream lines, but can also show rotation about the flow axis by twisting the ribbon-shaped flow line. The `streamribbon` function enables you to specify a twist angle (in radians) for each vertex in the stream ribbons.

When used in conjunction with the `curl` function, `streamribbon` is useful for displaying the curl angular velocity of a vector field. The following example illustrates this technique.

### 1. Select a Subset of Data to Plot

Load and select a region of interest in the wind data set using `subvolume`. Plotting the full data set first can help you select a region of interest.

```
load wind
lims = [100.64 116.67 17.25 28.75 -0.02 6.86];
[x,y,z,u,v,w] = subvolume(x,y,z,u,v,w,lims);
```

### 2. Calculate Curl Angular Velocity and Wind Speed

Calculate the curl angular velocity and the wind speed.

```
cav = curl(x,y,z,u,v,w);
wind_speed = sqrt(u.^2 + v.^2 + w.^2);
```

### 3. Create the Stream Ribbons

- Use `meshgrid` to create arrays of starting points for the stream ribbons. See "Starting Points for Stream Plots" in this chapter for information on specifying the arrays of starting points.
- `stream3` calculates the stream line vertices with a step size of `.5`
- `streamribbon` scales the width of the ribbon by a factor of 2 to enhance the visibility of the twisting (which indicates curl angular velocity).
- `streamribbon` returns the handles of the surface objects it creates, which are then used to set the color to red (`FaceColor`), the color of the surface edges to light gray (`EdgeColor`), and slightly increase the brightness of the ambient light reflected when lighting is applied (`AmbientStrength`).

```
[sx sy sz] = meshgrid(110,20:5:30,1:5);
verts = stream3(x,y,z,u,v,w,sx,sy,sz,.5);
```

```

h = streamribbon(verts,x,y,z,cav,wind_speed,2);
set(h,'FaceColor','r',...
    'EdgeColor',[.7 .7 .7],...
    'AmbientStrength',.6)

```

#### 4. Set the View and Add Lighting

- The `volumebounds` command provides a convenient way to set axis and color limits.
- Add a grid and set the view for 3-D (`streamribbon` does not change the current view).
- `camlight` creates a light positioned to the right of the view point and `lighting` sets the lighting method to Phong (which requires the zbuffer renderer).

```

axis(volumebounds(x,y,z,wind_speed))
grid on
view(3)
camlight right;
set(gcf,'Renderer','zbuffer'); lighting phong

```

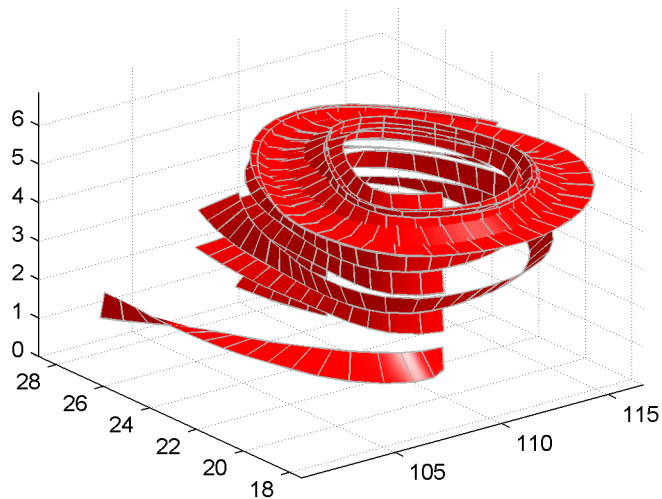

## Displaying Divergence with Stream Tubes

Stream tubes are similar to stream lines, except the tubes have width, providing another dimension that you can use to represent information.

By default, MATLAB indicates the divergence of the vector field by the width of the tube. You can also define widths for each tube vertex and thereby map other data to width.

This example uses the following techniques:

- Stream tubes indicate flow direction and divergence of the vector field in the wind data set.
- Slice planes colored to indicate the speed of the wind currents overlaid with contour line to enhance visibility

Inputs include the coordinates of the volume, vector field components, and starting location for the stream tubes.

### 1. Load Data and Calculate Required Values

The first step is to load the data and calculate values needed to make the plots. These values include:

- The location of the slice planes (maximum x, minimum y, and a value for the altitude)
- The minimum x value for the start of the stream tubes
- The speed of the wind (magnitude of the vector field)

```
load wind
xmin = min(x(:));
xmax = max(x(:));
ymin = min(y(:));
alt = 7.356; % z-value for slice and streamtube plane
wind_speed = sqrt(u.^2 + v.^2 + w.^2);
```

### 2. Draw the Slice Planes

Draw the slice planes (`slice`) and set surface properties to create a smoothly colored slice. Use 16 colors from the `hsv colormap`.

```
hslice = slice(x,y,z,wind_speed,xmax,ymin,alt);
set(hslice,'FaceColor','interp','EdgeColor','none')
```

```
colormap hsv(16)
```

### 3. Add Contour Lines to Slice Planes

Add contour lines (`contourslice`) to the slice planes. Adjust the contour interval so the lines match the color boundaries in the slice planes by:

- Calling `caxis` to get the current color limits
- Setting the interpolation method used by `contourslice` to `linear` to match the default used by `slice`.

```
color_lim = caxis;
cont_intervals = linspace(color_lim(1),color_lim(2),17);
hcont = contourslice(x,y,z,wind_speed,xmax,ymin,...
    alt,cont_intervals,'linear');
set(hcont,'EdgeColor',[.4 .4 .4],'LineWidth',1)
```

### 4. Create the Stream Tubes

Use `meshgrid` to create arrays for the starting points for the stream tubes, which begin at the minimum `x` value, range from 20 to 50 in `y`, and lie in a single plane in `z` (corresponding to one of the slice planes).

The stream tubes (`streamtube`) are drawn at the specified locations and scaled to be 1.25 times the default width to emphasize the variation in divergence (width). The second element in the vector `[1.25 30]` specifies the number of points along the circumference of the tube (the default is 20). You may want to increase this value as the tube size increases to maintain a smooth-looking tube.

Set the data aspect ratio (`daspect`) before calling `streamtube`.

Stream tubes are surface objects therefore you can control their appearance by setting (surface properties). This example sets surface properties to give a brightly lit, red surface.

```
[sx,sy,sz] = meshgrid(xmin,20:3:50,alt);
daspect([1,1,1]) % set DAR before calling streamtube
htubes = streamtube(x,y,z,u,v,w,sx,sy,sz,[1.25 30]);
set(htubes,'EdgeColor','none','FaceColor','r',...
    'AmbientStrength',.5)
```

### 5. Define the View

The final step is to define the view and add lighting (view, axis, volumebounds, Projection, camlight).

```
view(-100,30)
axis(volumebounds(x,y,z,wind_speed))
set(gca,'Projection','perspective')
camlight left
```

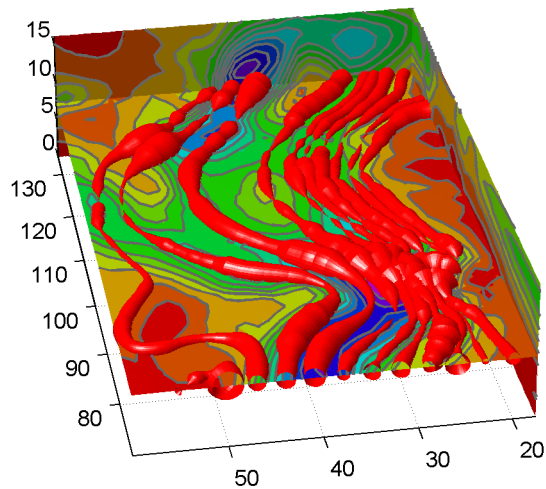

## Creating Stream Particle Animations

A stream particle animation is useful for visualizing the flow direction and speed of a vector field. The “particles” (represented by any of the line markers) trace the flow along a particular stream line. The speed of each particle in the animation is proportional to the magnitude of the vector field at any given point along the stream line.

### 1. Specify the Starting Points of the Data Range to Plot

This example determines the region of the volume to plot by specifying the appropriate starting points. In this case, the stream plots begin at  $x = 100$ ,  $y$  spans 20 to 50 and in the  $z = 5$  plane. Note that this is not the full volume bounds.

```
load wind
[sx sy sz] = meshgrid(100,20:2:50,5);
```

### 2. Create Stream Lines to Indicate the Particle Paths

This example uses stream lines (`stream3`, `streamline`) to trace the path of the animated particles. This adds a visual context for the animation. Another possibility is to set the `EraseMode` property of the stream particle to `none`, which would be useful for a single trace through the volume.

```
verts = stream3(x,y,z,u,v,w,sx,sy,sz);
sl = streamline(verts);
```

### 3. Define the View

While all of the stream lines start in the  $z = 5$  plane, the values of some spiral down to lower values. The following settings provide a clear view of the animation:

- The viewpoint (`view`) selected shows both the plane containing most stream lines as well as the spiral.
- Selecting a data aspect ratio (`daspect`) of `[2 2 0.125]` provides greater resolution in the  $z$ -direction to make the stream particles more easily visible in the spiral.
- Set the axes limits to match the data limits (`axis`) and draw the axis box (`box`).

```
view(-10.5,18)
daspect([2 2 0.125])
axis tight; box on
```

#### 4. Calculate the Stream Particle Vertices

The first step is to determine the vertices along the stream line where a particle should be drawn. The `interpstreamspeed` function returns this data based on the stream line vertices and the speed of the vector data. This example scales the velocities 0.05 to increase the number of interpolated vertices.

Setting the axes `DrawMode` property to `fast` enables the animation to run faster.

The `streamparticles` function sets the following properties:

- `Animate` to 10 to run the animation 10 times
- `ParticleAlignment` to `on` to start all particle traces together
- `MarkerEdgeColor` to `none` to draw only the face of the circular marker. Animations usually run faster when marker edges are not drawn.
- `MarkerFaceColor` to `red`
- `Marker` to `o`, which draws a circular marker. You can use other line markers as well.

```
iverts = interpstreamspeed(x,y,z,u,v,w,verts,0.05);
set(gca,'drawmode','fast');
streamparticles(iverts,15,...
    'Animate',10,...
    'ParticleAlignment','on',...
    'MarkerEdgeColor','none',...
    'MarkerFaceColor','red',...
    'Marker','o');
```



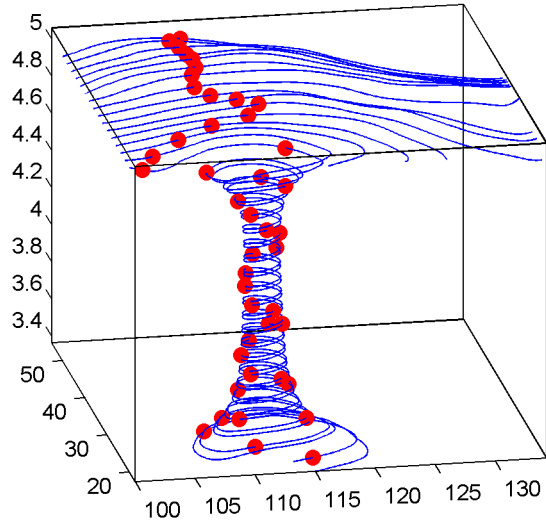

## Vector Field Displayed with Cone Plots

This example plots the velocity vector cones for the wind data. The graph produced employs a number of visualization techniques:

- An isosurface is used to provide visual context for the cone plots and to provide means to select a specific data value for a set of cones.
- Lighting enables the shape of the isosurface to be clearly visible.
- The use of perspective projection, camera positioning, and view angle adjustments compose the final view.

### 1. Create an Isosurface

Displaying an isosurface within the rectangular space of the data provides a visual context for the cone plot. Creating the isosurface requires a number of steps:

- Calculate the magnitude of the vector field, which represents the speed of the wind.
- Use `isosurface` and `patch` to draw an isosurface illustrating where in the rectangular space the wind speed is equal to a particular value. Regions inside the isosurface have higher wind speeds, regions outside the isosurface have lower wind speeds.
- Use `isonormals` to compute vertex normals of the isosurface from the volume data rather than calculate the normals from the triangles used to render the isosurface. These normals generally produce more accurate results.
- Set visual properties of the isosurface, making it red and without edges drawn (`FaceColor`, `EdgeColor`).

```
load wind
wind_speed = sqrt(u.^2 + v.^2 + w.^2);
hiso = patch(isosurface(x,y,z,wind_speed,40));
isonormals(x,y,z,wind_speed,hiso)
set(hiso,'FaceColor','red','EdgeColor','none');
```

### 2. Add Isocaps to the Isosurface

Isocaps are similar to slice planes in that they show a cross section of the volume. They are designed to be the end caps of isosurfaces. Using interpolated face color on an isocap causes a mapping of data value to color in the current

**colormap.** To create isocaps for the isosurface, define them at the same isovalue (isocaps, patch, colormap).

```
hcap = patch(isocaps(x,y,z,wind_speed,40),...
            'FaceColor','interp',...
            'EdgeColor','none');
colormap hsv
```

### 3. Create First Set of Cones

- Use `daspect` to set the data aspect ratio of the axes before calling `coneplot` so MATLAB can determine the proper size of the cones.
- Determine the points at which to place cones by calculating another isosurface that has a smaller isovalue (so the cones display outside the first isosurface) and use `reducepatch` to reduce number of faces and vertices (so there are not too many cones on the graph).
- Draw the cones and set the face color to blue and the edge color to none.

```
daspect([1,1,1]);
[f verts] = reducepatch(isosurface(x,y,z,wind_speed,30),0.07);
h1 = coneplot(x,y,z,u,v,w,verts(:,1),verts(:,2),verts(:,3),3);
set(h1,'FaceColor','blue','EdgeColor','none');
```

### 4. Create Second Set of Cones

- Create a second set of points at values that span the data range (`linspace`, `meshgrid`).
- Draw a second set of cones and set the face color to green and the edge color to none.

```
xrange = linspace(min(x(:)),max(x(:)),10);
yrange = linspace(min(y(:)),max(y(:)),10);
zrange = 3:4:15;
[cx,cy,cz] = meshgrid(xrange,yrange,zrange);
h2 = coneplot(x,y,z,u,v,w,cx,cy,cz,2);
set(h2,'FaceColor','green','EdgeColor','none');
```

## 5. Define the View

- Use the `axis` command to set the axis limits equal to the minimum and maximum values of the data and enclose the graph in a box to improve the sense of a volume (`box`).
- Set the projection type to perspective to create a more natural view of the volume. Set the view point and zoom in to make the scene larger (`camproj`, `camzoom`, `view`).

```
axis tight
box on
camproj perspective
camzoom(1.25)
view(65,45)
```

## 6. Add Lighting

Add a light source and use Phong lighting for the smoothest lighting of the isosurface (Phong lighting requires the `zbuffer` renderer). Increase the strength of the background lighting on the isocaps to make them brighter (`camlight`, `lighting`, `AmbientStrength`).

```
camlight(-45,45)
set(gcf,'Renderer','zbuffer');
lighting phong
set(hcap,'AmbientStrength',.6)
```

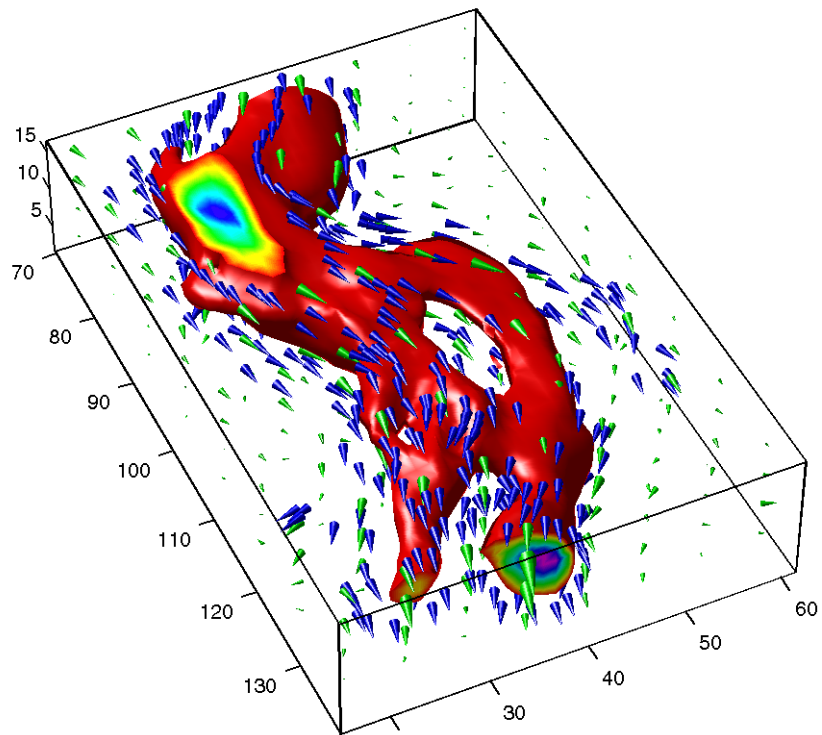



## Symbols

- 3-29
- A**
- alpha values 13-4
- ambient light 12-13
- AmbientLightColor property 12-8
  - illustration 12-13
- AmbientStrength property 12-8
  - illustration 12-13
- animation 4-51
  - erase modes for 4-53
  - movies 4-51
- annotating graphs 3-1
  - adding a legend 3-6
  - adding a title 3-3
  - adding labels 3-11
  - adding plots of data statistics 3-29
  - adding text 3-15
- annotations
  - adding 1-13, 3-16
- area 4-3, 4-12
- area graphs 4-3, 4-12
- arrays, storing images 5-4
- arrow annotations
  - adding 1-13
- arrows
  - adding to a graph 3-28
- aspect ratio 11-41–11-55
  - for realistic objects 11-54
  - properties that affect 11-46
  - specifying 11-50
- axes
  - adding labels 3-11
  - adding text 3-17
  - aspect ratio 11-41, 11-46
  - 2-D 2-24
  - 3-D 11-41
    - properties that affect 11-46
    - specifying 11-50
  - automatic modes 8-19
  - axis control 8-10
  - axis direction 8-13
  - camera properties 11-30
  - CLim property 8-25
  - color limits 8-25
  - ColorOrder property 8-30
  - colors 8-22
  - controlling the shape of 11-50
  - default aspect ratio 11-47
  - functions for 1-8
  - individual axis control 8-10
  - labeling 3-13
  - labels
    - font properties 8-4
    - using TeX characters 3-23
  - limits 11-41
    - example 11-53
  - locking position 1-8
  - making grids coincident 8-17
  - multi-axis 8-16
  - multiple 2-26, 8-7
  - NextPlot property 7-38
  - overlapping 8-7
  - plot box 11-8
  - position rectangle 11-31
  - positioning 8-5–8-9
  - preparing to accept graphics 7-37
  - properties
    - for labeling 8-3
    - list 8-2
  - properties of 1-9

- protecting from output 7-43
  - scaling 11-41
    - independent 8-8
  - setting
    - limits 8-11
      - line styles used for plotting 8-31
    - setting limits 2-19
    - standard plotting behavior 7-42
    - stretch-to-fill 11-41
    - target for graphics 2-28
    - tick marks 2-21
      - locating 8-12
    - units 8-6
    - unlocking position 1-8
    - with two x and y axes 8-16
  - axis 5-2
  - axis 11-41
    - auto 11-41
    - equal 2-24, 11-42
    - ij 11-42
    - illustrated examples, 2-D 2-24
    - illustrated examples, 3-D 11-43
    - image 5-20, 11-42
    - manual 11-42
    - normal 11-42
    - square 2-24, 11-42
    - tight 2-25, 11-42
    - vis3d 11-42
    - xy 11-42
  - azimuth of viewpoint 11-4
    - default 2-D 11-4
    - default 3-D 11-5
    - limitations 11-7
- B**
- BackFaceLighting property 12-9
  - illustration 12-15
  - backing store 9-15
  - bar 4-3, 4-4
  - bar graphs 4-3–4-12
    - 3-D 4-4
      - grouped
        - 2-D 4-3
        - 3-D 4-5
      - horizontal 4-7
      - labeling 4-5, 4-8
      - overlaid with plots 4-10
      - stacked 4-6
    - bar3 4-3, 4-4
    - bar3h 4-3
    - barh 4-3
    - binary images 5-8
    - bins, specifying for histogram 4-21
    - BMP 5-2
    - brighten 10-20
    - buttons on toolbar 1-13, 1-14, 3-16, 3-28

**C**

    - camdolly 11-21
    - camera position, moving 11-31
    - camera properties 11-30
      - illustration showing 11-8
    - camera toolbar 11-9
    - CameraPosition property 11-30
      - and perspective 11-31
      - fly-by 11-31
    - CameraPositionMode property 11-30
    - CameraTarget property 11-30
    - CameraTargetMode property 11-30
    - CameraUpVector property 11-30, 11-34
      - example 11-35
    - CameraUpVectorMode property 11-30



- CameraViewAngle property 11-30
  - and perspective 11-33
  - zooming with 11-33
- CameraViewAngleMode property 11-30, 11-33
- camlookat property 11-21
- camorbit 11-21
- campan 11-21
- campos 11-21
- camproj 11-21
- camroll 11-21
- camtarget 11-21
- camup 11-21
- camva 11-21
- camzoom 11-21
- CData property
  - images 5-23
  - patches 14-11
- CDataMapping property 10-18
  - images 5-23
  - patches 14-11
- cla 7-38
- clabel 4-38, 4-40
- clf 7-38
- close 7-45
- close request function
  - default 7-45
- closereq.m 7-45
- CloseRequestFcn property 7-45
  - default value 7-45
  - errors in 7-46
  - overriding 7-46
- closing figures 7-45
- closing MATLAB, errors occurring when 7-46
- color limits, calculating 8-26
- color property of lights 12-4
- colorbar 10-16
- colordef 2-29
- colormap 10-15
- colormaps
  - altering 10-20
  - brightening 10-20
  - brightness component of TV signal 10-21
  - displaying 10-16
  - for surfaces 10-14
  - functions that create 10-15
  - large 9-9
  - minimum size 9-10
  - range of RGB values in 10-14
  - simulating multiple 8-25
  - size of dithermap 9-14
- ColorOrder 8-29
- colors
  - changing color scheme 8-23
  - colormaps 9-8, 10-14
  - controlled by axes 8-22
  - controlled by figure properties 9-7
  - dithering 9-12, 10-24
  - effects of dithering 9-14
  - fixed 9-8
  - indexed 10-14
    - direct 10-17
    - scaled 10-17
  - indexed and dithering 9-12
  - interpreted by surfaces 10-14
  - mapping to data 8-25
  - NTSC encoding of 10-21
  - of patches 14-11
  - of surface plots 10-14
  - scaling algorithm 10-18
  - shared 9-11
  - size of dithermap 9-14
  - specifying Figure colors 2-28
  - specifying for surface plot, example 10-18
  - truecolor 10-14

- on indexed color systems 10-24
- specifying 10-22
- typical RGB values 10-15
- used for plotting 8-29
- using a large number 9-9
- compass 4-32
- compass plots 4-32
- complex numbers, plotting 2-15
  - with feather 4-34
- cone plots 15-40
- contour 4-38
- contour plots 4-38
  - algorithm 4-43
  - filled 4-41
  - in polar coordinates 4-45
  - labeling 4-40
  - specifying contour levels 4-42, 4-44
- contour3 4-38
- contourc 4-38, 4-43
- contourf 4-38, 4-41
- conv2 5-13
- converting the data class of an indexed image
  - 5-11
- convn 5-13
- coordinate system and viewpoint 11-4
- copying
  - figures 1-11
  - options 1-11
- copying graphics objects 7-33
- current
  - Axes 7-30
  - Figure 7-30
  - object 7-30
- cursors, see pointers

## D

- data statistics
  - formatting plots of of 3-32
  - plotting 3-29, 3-32
- Data Statistics tool
  - example 3-30
  - interface 3-30
  - overview 1-22
  - saving to workspace 3-34
- data types
  - 8-bit integers 5-4
  - double-precision 5-4
- DataAspectRatio property 11-46
  - example 11-50
  - images 5-21
- DataAspectRatioMode property 11-46
- default
  - aspect ratio 11-47
  - azimuth
    - 2-D 11-4
    - 3-D 11-5
  - CameraPosition 11-31
  - CameraTarget 11-31
  - CameraUpVector 11-31
  - CameraViewAngle 11-31
  - CloseRequestFcn 7-45
  - elevation
    - 2-D 11-4
    - 3-D 11-5
  - factory 7-22
  - figure color scheme 2-28
  - Projection 11-31
  - property values 7-23-??
    - removing 7-25
    - search path, diagram 7-23
    - setting to factory defaults 7-26
  - view 11-31

- default line styles, setting and removing 2-11
  - del2 10-18
  - deleting graphics objects 7-35
  - deselecting objects 1-8
  - diffuse reflection 12-12
  - DiffuseStrength property 12-8
    - illustration 12-12
  - direct color mapping 10-17
  - direction cosines 11-34
  - discrete data graphs 4-23–4-31
    - stairstep plots 4-30
    - stem plots 4-23
  - dithering 9-12
    - algorithm 9-12
    - effects of 9-14
  - Dithermap property 9-12
  - DithermapMode property 9-12, 9-13
  - documentation 1-12
  - double 5-29
  - double
    - converting double to uint8 or uint16 5-11
    - converting image data to double 5-29
  - double buffering 9-15
  - double converting double to uint16 5-12
  - double converting double to uint8 5-12
- E**
- edge effects and lighting 12-16
  - EdgeColor property 12-9
  - EdgeLighting property 12-9
  - edges of patches 14-14
  - Edit menu
    - starting Property Editor 1-16
  - editing plots
    - interactively 1-6
  - efficient programming 7-48, 7-49
  - elevation of viewpoint 11-4
    - default 2-D 11-4
    - default 3-D 11-5
    - limitations 11-7
  - ending plot edit mode 1-7
  - erase modes 4-53
    - and printing 4-55
    - background 4-55
    - images 5-26
    - none 4-53
    - xor 4-56
  - errors closing MATLAB 7-46
  - examples
    - 3-D graph 10-3
    - animation 4-53
    - area graphs 4-12
    - axis 11-43
    - bar graphs 4-4
    - changing CameraPosition 11-32
    - contour plots 4-38
    - copying graphics objects 7-33
    - custom pointers 9-20
    - DataAspectRatio property 11-50
    - del2 10-18
    - direction and velocity graphs 4-32
    - direction cosines 11-34
    - discrete data graphs 4-23
    - displaying real objects 11-54
    - double axis graphs 8-16
    - finding objects handles 7-32
    - histograms 4-18
    - hold 7-43
    - line 7-40
    - linspace 10-10
    - meshgrid 10-4, 10-10
    - movies 4-52
    - multiline text 3-25

- newplot 7-40
- object creation functions 7-13
- of lighting 12-2
- overlapping axes 8-7
- parametric surfaces 10-12
- pie charts 4-15
- placing text dynamically 3-21
- plot 2-2
  - complex data 2-15
- plot3 10-4
- PlotBoxAspectRatio property 11-52
- plotting linestyles 8-31
- ScreenSize property 9-5
- setting default property values 7-26
- simulating multiple colormaps 8-25
- specifying figure position 9-5
- specifying truecolor
  - surfaces 10-22
- stretch-to-fill 11-50
- subplot 2-26
- text 3-16
- texture mapping 10-25
- unevenly sampled data 10-9
- view 11-33

exporting figures 1-11

extent of computer screen 9-4

## F

- FaceColor property 12-9
- FaceLighting property 12-8
- Faces property 14-7
- FaceVertexCData property 14-9, 14-11
- factory defaults 7-22
- feather 4-32, 4-33
- feather plots 4-33
- fft2 5-13

- fft2 5-13
- figure files 1-10
- figures
  - CloseRequestFcn 7-45
  - closing 7-45
  - copying 1-11
  - defining custom pointers 9-19
  - defining pointers 9-18
  - defining the color of 2-28
  - fixed colors 9-8
  - for plotting 2-26
  - index color properties 9-7
  - introduction to 9-2
  - NextPlot property 7-38
  - nonactive 9-11
  - opening 1-10
  - positioning 9-3
  - positioning example 9-5
  - preparing to accept graphics 7-37
  - protecting from output 7-43
  - rendering properties 9-15
  - saving 1-10
  - specifying pointers 9-18
  - standard plotting behavior 7-42
  - units 9-4
  - visible property 7-45
  - with multiple axes 2-26
- files
  - exporting 1-11
  - figure fig 1-10
  - formats for figures 1-11
  - opening 1-10
  - printing 1-11
  - saving 1-10
- fill, properties changed by 7-49
- fill3, properties changed by 7-49
- findobj 7-32

- fixed colors 9-8
  - FixedColors property 9-8
  - Floyd-Steinberg dithering algorithm 9-12
  - fly-by effect 11-31
  - fonts
    - axis labels 8-4
  - formats for figures 1-11
  - functions
    - convenience forms 7-16
    - high-level vs. low-level 7-15
    - to create graphics objects 7-12
- G**
- gca 7-31
    - handle visibility 7-44
  - gcf 7-31
    - handle visibility 7-44
  - gco 7-31
  - get 7-18
  - getframe 4-51
  - ginput 4-49
  - Gouraud lighting algorithm 12-10
  - gradient 4-36
  - graphical input 4-49
  - graphics
    - M-files, structure of 7-41
  - graphics file formats
    - list of formats supported by MATLAB 5-2
  - graphics images
    - 16-bit
      - intensity 5-12
    - 8-bit
      - intensity 5-12
      - RGB 5-12
    - converting from one format to another 5-29
    - converting to RGB 5-29
    - reading from file 5-15
    - see also BMP, HDF, JPG, PCX, PNG, TIFF, XWD 5-16
    - writing to file 5-16
  - graphics objects 7-4
    - accessing handles 7-30
    - accessing hidden handles 7-44
    - axes 7-7
    - controlling where they draw 7-37
    - copying 7-33
    - deleting 7-35
    - editing properties 1-9, 1-17
    - figures 7-5
    - functions that create 7-12
      - convenience forms 7-16
    - handle validity versus visibility 7-46
    - HandleVisibility property 7-43
    - hierarchy 7-3
    - images 7-7
      - See also Image chapter
    - invisible handles 7-43
    - lights 7-7
    - line 7-7
    - patches 7-8
    - properties 7-9
      - changed by functions 7-49
      - changed when created 7-14
      - common to all objects 7-10
      - factory defined 7-22
      - getting current values 7-20
      - listing possible values 7-19
      - querying in groups 7-22
      - search path for default values 7-23
      - searching for 7-32
      - setting values 7-18
    - property names 7-16
    - rectangle 7-8

- root 7-5
- setting parent of 7-15
- specifying tag value 1-20
- surface 7-8
- text 7-8
- uicontrol 7-5
- uimenu 7-6
- graphs
  - area 4-12–4-14
  - bar 4-3–4-12
    - horizontal 4-7
  - compass plots 4-32
  - contour plots 4-38–4-47
  - direction and velocity 4-32–4-37
  - discrete data 4-23–4-31
  - feather plots 4-33
  - histograms 4-18–4-22
  - labeling 3-1
  - pie charts 4-15–4-17
  - quiver plots 4-35
  - stairstep plots 4-30
  - steps to create 3-D 10-3
  - with double axes 8-16
- grayscale 5-17
  - see also* intensity images 5-17
- Greek characters
  - see* text function
  - using to annotate 3-14
- griddata 10-10
- grids, coincident 8-17

## H

- Hadamard matrix 10-12
- Handle Graphics
  - graphics objects 7-4
  - hierarchy of graphics objects 7-3

- handles to graphics objects 7-30
  - finding 7-32
- handles, saving in M-files 7-48
- HandleVisibility property 7-43
- HDF 5-2
- help 1-12
- hidden 10-13
- hidden line removal 10-13
- high-level functions 7-15
- hist 4-18
- histograms 4-18
  - in polar coordinates 4-20
  - labeling the bins 4-21
  - rose plot 4-20
  - specifying number of bins 4-21
- hold 2-7
  - and NextPlot 7-39
  - testing state of 7-42
- hold state, testing for 7-42
- HorizontalAlignment property 3-19

## I

- image 5-2
- image 5-19
  - properties changed by 7-49
- image types
  - binary 5-8
- images
  - 16-bit 5-11
    - indexed 5-11
  - 8-bit 5-11
    - indexed 5-11
  - data types 5-4
  - erase modes 5-26
  - indexed 5-6
  - information about files 5-16

- intensity 5-7
  - numeric classes 5-2
  - printing 5-28
  - properties 5-23
    - CData 5-23
    - CDataMapping 5-23
    - XData and YData 5-24
  - RGB 5-9
  - see also graphics images 5-12
  - size and aspect ratio 5-19
  - storing in MATLAB 5-4
  - truecolor 5-9
  - types 5-6
  - imagesc 5-2
  - imagesc 5-8
  - imagesc 5-8
  - imfinfo 5-3
  - imfinfo 5-16
  - imread 5-2
  - imread 5-15
  - imwrite 5-3
  - imwrite 5-16
  - ind2rgb 5-29
  - indexed color
    - displays 9-7
    - dithering truecolor 9-12
    - surfaces 10-14
  - indexed images
    - converting the data class of 5-11
  - indirgb 5-3
  - Infs, avoiding in data 10-7
  - intensity images
    - converting the data class of 5-12
  - interpolated colors
    - patches 14-9
      - indexed vs. truecolor 14-19
  - interpreter property 3-24
  - ishold 7-42
  - isosurface
    - illustrating flow data 15-19
- ## J
- JPEG 5-2
- ## L
- labeling
    - axes 3-11
  - labeling graphs 3-1, 3-11
  - Laplacian of a matrix 10-18
  - LaTeX. See TeX
  - legend
    - adding to a graph 3-6
    - editing text labels 3-9
    - positioning in a graph 3-8
  - legend 4-26
  - legends
    - with data statistics 3-31
  - light 12-4
  - lighting 12-2–12-19
    - algorithms
      - flat 12-10
      - Gouraud 12-10
      - Phong 12-10
    - ambient light 12-13
    - backface 12-15
    - diffuse reflection 12-12
    - important properties 12-4
    - properties that affect 12-8
    - reflectance characteristics 12-12–12-15
  - specular
    - color 12-15
    - exponent 12-14

- reflection 12-12
- lighting command 12-11
- limits
  - axes 2-19, 8-11
- line styles
  - used for plotting 2-5
  - redefining 8-31
- lines
  - adding as annotations 3-28
  - adding to existing graph 2-7
  - annotations 1-13
  - marker types 2-5
  - properties of 1-9
  - removing hidden 10-13
  - styles 2-5
- LineStyleOrder property 8-31
- linspace 10-9
- locking axes position 1-8
- loglog, properties changed by 7-49
- low-level functions 7-15

## M

- mapping data to color 8-25
- markers used for plotting 2-5
- material command 12-12
- mathematical functions
  - visualizing with surface plot 10-7
- MATLAB 4 color scheme 2-29
- MATLAB, quitting 7-46
- matrix
  - displaying contours 4-39
  - Hadamard 10-12
  - plotting 2-13
  - representing as
    - area graph 4-12
    - bar graph 4-4

- histogram 4-19
  - surface 10-6
  - storing images 5-4
- menus 1-8
- mesh 10-6
- meshc 4-44
- meshgrid 10-7
- M-files
  - basic structure of graphics 7-41
  - closereq 7-45
  - to set color mapping 8-28
  - using newplot 7-39
  - writing efficient 7-48
- min
  - plotting 3-29
- MinColorMap property 9-9
- movie 4-51, 4-52
- movies 4-51
  - example 4-52
- moving
  - objects 1-8
- MRI data, visualizing 15-8
- multiaxis axes 8-16
- multiline text 3-25

## N

- navigation bar
  - in Property Editor 1-18
- newplot 7-39
  - example using 7-40
- NextPlot property 7-38
  - add 7-38
  - replace 7-38
  - replacechildren 7-38, 7-42
  - setting plotting color order 8-30
- nonuniform data, plotting 10-9



NormalMode property 12-9  
NTSC color encoding 10-21

## O

object properties  
  editing 1-15  
online help 1-12  
open 1-10, 1-11  
OpenGL 9-16, 9-17  
opening figures 1-10  
options for copying 1-11  
organization of Handle Graphics 7-3  
orthographic projection 11-36  
  and Z-buffer 11-38

## P

page setup 1-11  
painters algorithm 9-16  
parametric surfaces 10-11  
parent, of graphics object 7-15  
patch  
  behavior of function 14-2  
  interpreting color 14-3  
patches  
  coloring 14-11  
    faces and edges 14-13  
  face coloring  
    flat 14-8  
    interpolated 14-9  
  indexed color 14-16  
    direct 14-18  
    scaled 14-16  
  interpreting color data 14-16  
  multifaceted 14-6  
  single polygons 14-4

  specifying faces and vertices 14-7  
  truecolor 14-19  
  ways to specify 14-2  
PCX 5-2  
perspective projection 11-36  
  and Z-buffer 11-38  
Phong lighting algorithm 12-10  
pie charts 4-15  
  labeling 4-16  
  offsetting a slice 4-15  
  removing a piece 4-17  
plot 2-2  
  properties changed by 7-50  
plot box 11-8  
plot edit mode, starting and ending 1-7  
plot editing mode  
  overview 1-6  
plot3 10-4  
  properties changed by 7-50  
PlotBoxAspectRatio property 11-46  
  example 11-52  
PlotBoxAspectRatioMode property 11-46  
plottedit 1-7  
plots  
  editing object in 1-17  
plotting  
  3-D  
    matrices 10-4  
    vectors 10-4  
  adding to existing graph 2-7  
  annotating graphs 3-1  
  area graphs 4-12  
  bar graphs 4-3  
  compass plots 4-32  
  complex data 2-15  
  contour plots 4-38  
  contours, labeling 4-40

- creating a plot 2-2
- data-point markers 2-5
- elementary functions for 2-2
- feather plots 4-33
- interactive 4-49
- line colors 8-29
- line styles 2-5
- matrices 2-13
- multiple graphs 2-3
- nonuniform data 10-9
- overlying bar graphs 4-10
- quiver plots 4-35
- specifying line styles 2-4, 8-31
- stairstep plots 4-30
- stem plots 4-23
- surfaces 10-6
- to subaxis 2-26
- vector data 2-2
- windows for 2-26
- plotting statistics 3-32
- PNG 5-2
  - writing as 16-bit using `imwrite` 5-16
- Pointer property 9-19
- pointers
  - custom 9-19
    - example defining 9-20
    - specifying 9-18
- PointerShapeCData property 9-19
- PointerShapeHotSpot property 9-19
- polar 4-47
- polar coordinates
  - contour plots 4-45
  - rose plot 4-20
- polygons, creating with `patch` 14-2
- pop-up menus 1-8
- position of figure 9-3
- Position property
  - axes 8-5
  - figure 9-3
  - position rectangle 11-8
  - positioning axes 1-8
  - positioning of axes 8-5
  - positioning text on a graph 3-17
  - preferences 1-11
  - printing
    - 3-D scenes 11-39
    - images 5-28
    - Print dialog box 6-26
    - quick start 6-3
    - resolution
      - with painters renderer 9-17
      - with Z-buffer renderer 9-17
    - troubleshooting 6-55
    - Z-buffer 9-17
- printing figures 1-11
- Projection property 11-30
- projection types 11-36–11-40
  - camera position 11-37
  - orthographic 11-36
  - perspective 11-36
  - rendering method 11-38
- properties
  - automatic axes 8-19
  - axes 8-2
  - changed by built-in functions 7-49
  - changed by object creation functions 7-14
  - defining in `startup.m` 7-29
  - editing 1-9, 1-15
  - for labeling axes 8-3
  - naming convention 7-16
  - See also graphics objects
  - specifying default values 7-25
- Property Editor
  - closing 1-16

- editing multiple objects 1-18
- interface 1-15
- overview 1-15
- searching for objects 1-20
- starting 1-16
- using the navigation bar 1-18
- property values
  - defaults 7-23
  - defined by MATLAB 7-22
  - getting 7-18
  - resetting to default 7-25
  - setting 7-18
  - specifying defaults 7-25
  - user defined 7-23
- pseudocolor displays, see indexed color

## Q

- quiver 4-32, 4-35
- quiver plots 4-35
  - 2-D 4-35
  - 3-D 4-36
  - combined with contour plot 4-36
  - displaying velocity vectors 4-37
- quiver3 4-32

## R

- realism, adding with lighting 12-2
- realistic display of objects 11-54
- reflection, specular and diffuse 12-12
- Renderer property 10-24
  - and printing 9-17
- RendererMode property 10-24
- rendering
  - options 9-15
  - Z-buffer 9-16

- reset 7-38
- resizing
  - objects 1-8
- RGB
  - color values 10-15
  - converting to 5-29
  - images 5-9
    - converting the data class of 5-12
- rgbplot 10-20
- right-clicking 1-8
- rose 4-18, 4-20
- rotating a plot 1-14
- rotation
  - about viewing axis 11-34
  - without resizing 11-33

## S

- saveas 1-10
- saving figures 1-10
- scaled color mapping 10-17
- screen extent, determining 9-4
- ScreenSize property 9-4
  - example 9-5
- selecting multiple objects 1-7
- selection button 1-7
- semilogx, properties changed by 7-50
- semilogy, properties changed by 7-50
- set 7-18
- ShareColors property 9-11
- ShowHiddenHandles property 7-44
- size of computer screen 9-4
- slice planes
  - colormapping 15-17
  - slicing a volume 15-14
- specular
  - color 12-15

- exponent 12-14
- highlight 12-14
- reflection 12-12
- SpecularColorReflectance property 12-8
  - illustration 12-15
- SpecularExponent property 12-8
  - illustration 12-14
- SpecularStrength property 12-8
  - illustration 12-12
- sphere 10-25
- spline 4-49
- stairs 4-23, 4-30
- stairstep plot 4-30
- starting plot edit mode 1-7
- starting points for stream plots 15-26
- statistics
  - formatting plots of 3-32
  - plotting 3-29, 3-32
  - saving to workspace 3-34
- stem 4-23
- stem plots 4-23
  - 3-D 4-27
  - overlaid with line plot 4-26
- stem3 4-23, 4-27
- stream line plots 15-30
- stream plots
  - starting points 15-26
- stretch-to-fill 11-41
  - overriding 11-49
- string variable, in text 3-25
- style property of lights 12-4
- subplot 2-26
- sum 5-13
- surf 10-6
- Surfaces
  - CData 10-25
  - coloring 10-14
  - curvature mapped to color 10-18
  - FaceColor, texturemap 10-25
  - parametric 10-11
  - plotting 10-6
    - nonuniformly sampled data 10-9
  - surf 4-44
  - symbols, TeX characters 3-23
- T
- tag
  - specifying value of 1-20
- TeX
  - available characters 3-23
  - creating mathematical symbols 3-23
  - symbols in text 3-14, 3-24
- text
  - adding to Axes 3-16, 3-23
  - annotating graphs 3-16
  - annotations, adding 1-13
  - editing 1-8, 3-22
  - for labeling plots 3-16
  - horizontal and vertical alignment 3-19
  - multiline 3-25
  - placing dynamically, example 3-21
  - placing outside of axes 8-7
  - positioning 3-19
  - TeX characters 3-24
  - using variables in 3-25
- texture mapping 10-25
- thin line styles 6-57
- three-dimensional objects, creating with patch
  - 14-2
- tick marks, on axes 2-21, 8-12
- TIFF 5-2
- title
  - adding to a graph 3-3

- toolbar
  - buttons 1-13, 1-14, 3-16, 3-28
- toolbar, camera 11-9
- truecolor
  - dithering on indexed systems 9-12
  - patches 14-19
  - rendering method used for 10-24
  - simulating 10-24
  - surface plots 10-14, 10-22
  
- U**
- Uicontrol graphics objects 7-5
- Uimenu graphics objects 7-6
- uint16 arrays
  - operations supported on 5-13
  - storing images 5-5
- uint16 arrays
  - converting uint16 to double 5-11, 5-12
- uint8 arrays 5-11
  - operations supported on 5-13
  - storing images 5-5
- uint8 arrays
  - converting to double 5-12
  - converting uint8 to double 5-11
- units
  - axes 8-6
  - used by figures 9-4
- unlocking axes position 1-8
- unselecting objects 1-8
  
- V**
- vectors
  - determined by direction cosines 11-34
  - displaying velocity 4-37
- velocity vectors displayed with quiver 4-37
  
- vertex normals and back face lighting 12-16
- VertexNormals property 12-9
- VerticalAlignment property 3-19
- Vertices property 14-7
- view
  - azimuth of viewpoint 11-4
  - camera properties 11-30
  - coordinate system defining 11-4
  - definition of 11-2
  - elevation of viewpoint 11-4
  - limitation of azimuth and elevation 11-7
  - MATLAB's default behavior 11-31
  - projection types 11-36
  - rotating 1-14
  - specifying 11-30
  - specifying with azimuth and elevation 11-4
- view 11-4
  - example of rotation 11-33
  - limitations using 11-7
- viewing axis 11-8
  - moving camera along 11-32
- viewpoint, controlling 11-4, ??-11-7
- visibility of graphics objects 7-46
- visualizing
  - commands for volume data 15-5
  - mathematical functions 10-7
  - steps for volume data 15-4
  - techniques for volume data 15-3
- volume data
  - accessing subregions 15-28
  - examples of 15-3
  - MRI 15-8
  - scalar 15-7
  - slicing with plane 15-14
  - steps to visualize 15-4
  - techniques for visualizing 15-3
  - vector 15-25

visualizing 15-3

## **W**

wire frame surface 10-6, 10-13

## **X**

XWD 5-2

## **Z**

Z-buffer 9-16

orthographic projection 11-38

perspective projection 11-38

printing 9-17

rendering truecolor 10-24

zooming by setting camera angle 11-33